

2015-20XX CHEVY 2500-3500

FRONT BUMPER INSTALLATION INSTRUCTIONS



SAFETY

Know safety, no injury. Know injury, no safety. ~Author Unknown

If there are any questions, call 1-855-HHTOUGH

- **READ ALL SAFETY INSTRUCTIONS BEFORE INSTALLATION**
 - FOLLOW ALL INSTRUCTIONS FOR PROPER ASSEMBLY
 - WEAR APPROPRIATE EYE PROTECTION
 - EXERCISE CARE WHEN LIFTING COMPONENTS
 - USE APPROPRIATE TORQUE FOR BOLTS
 - BLUE THREAD LOCKING COMPOUND IS RECOMMENDED ON ALL BOLTS

- SUGGESTED TORQUE VALUES FOR STEEL GRADE SAE 5 BOLTS

BOLT DIAMETER (INCH)	TREADS PER INCH	TORQUE (POUND-FEET)
1/4	20	7
5/16	18	14
3/8	16	25
7/16	14	40
1/2	13	60
9/16	12	88
5/8	11	120
3/4	10	200
7/8	9	302
1	8	466



2015-20XX Chevrolet 2500-3500 Front

I. PARTS LIST

ITEM NO.	QTY.	PART NUMBER	DESCRIPTION	
1	2	316-01-0005	1.25" PLUG BT-FLUSH LDPE BLACK	-
2	2	601-56-2316	OUTSIDE PLUG	-
3	2	601-56-2401	2014 GM SENSOR SOLUTION	-
4	2	601-56-2498	WELDNUT TAB	-
5	2	601-56-2868	WELDNUT TAB 3	-
6	1	601-56-2958	RIGHT BAR MOUNT	-
7	1	601-56-2959	LEFT BAR MOUNT	-
8	1	601-56-3042	RIGHT FRAME MOUNT WELDMENT	-
9	1	601-56-3043	LEFT FRAME MOUNT WELDMENT	-
10	1	60K-56-0057	HARDWARE KIT #57	-
11	1	60K-56-0062	HARDWARE KIT #62	-
12	1	60P-56-0415	600-56-0415 POLISHED	-

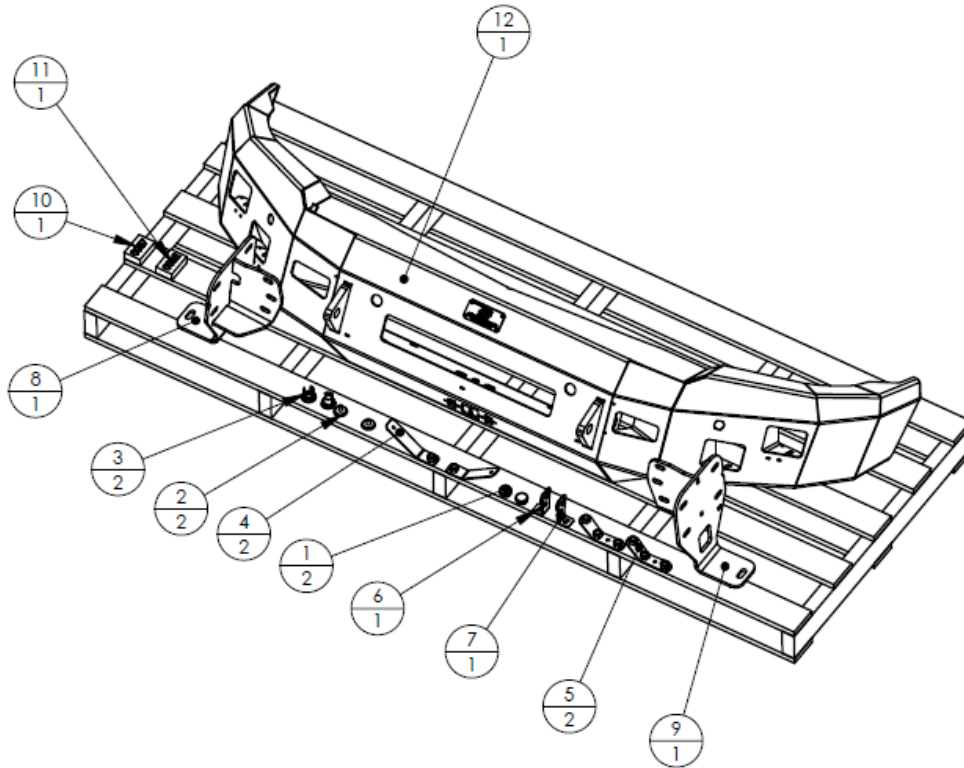

REMOVE CONTENTS FROM BOX AND VERIFY ALL PARTS ARE PRESENT.
 If there are any questions, call 1-855-HHTOUGH or email
HHORDERS@hammerheadarmor.com



2015-20XX Chevrolet 2500-3500 Front

II. TOOL LIST

1. ¾" wrench
2. ¾" socket
3. 7/16" socket
4. 7/16" wrench
5. Trim tool
6. 10mm socket
7. 15mm socket
8. 18mm socket
9. 18mm wrench

III. REMOVAL OF OEM BUMPER

1. Using trim tool, remove 12 plastic retainers in OEM plastic shroud. Gently set aside. It will be reused.

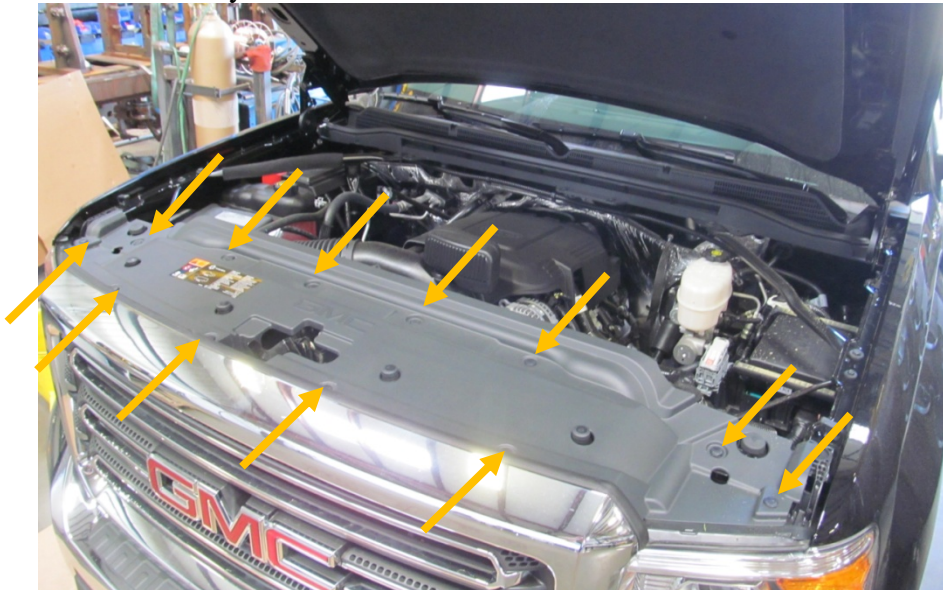

2. Using 10mm socket, remove four screws in top of grill.





2015-20XX Chevrolet 2500-3500 Front

3. Gently pull out on grill to remove. Start at top by pulling up and then out. Then pull out on bottom. Gently set aside. It will be reused.



4. Using 15mm socket, remove 3 bolts from OEM bumper side brace. Set aside. (both sides)



5. Unplug OEM sensor/fog light harness. (if applicable)



6. Using 18mm socket, remove four bolts attaching OE bumper to frame mounts. The bolt heads are behind the bumper and can be accessed from the top. Set bumper aside.



2015-20XX Chevrolet 2500-3500 Front

7. Using 15mm socket, remove eight bolts attaching OE bumper brackets. Set brackets aside.

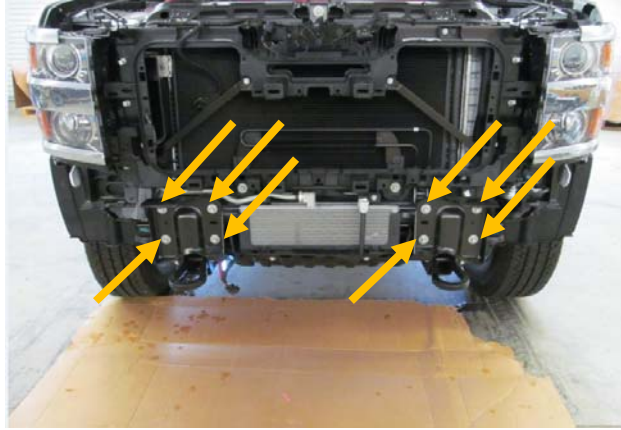

8. Using 18mm socket and wrench, remove OE tow hook. Set tow hook aside. (both sides)



IV. INSTALLATION OF HAMMERHEAD BUMPER

1. If your truck is equipped with sensors, install OE sensor grommets in two outer holes of Hammerhead bumper. Make sure they are oriented in the same way they were in the OE bumper.



2. Install Hammerhead sensor solutions (601-56-2401) in two center holes of Hammerhead bumper. Then install OE sensors and wiring harness. Make sure the sensors are oriented in the same way they were in the OE bumper. NOTE: The plug will be horizontal.



2015-20XX Chevrolet 2500-3500 Front

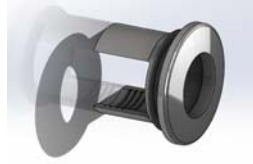

3. If your truck is not equipped with sensors, install provided plugs in sensor holes.



4. Install all lights in Hammerhead bumper at this time. Use included Bar mount brackets (601-56-2958 and 2959) and Hardware kit #57 to attach 20" bar in bumper to mount in bumper. Use hole in bracket and bumper that works best with your light bar. Tighten bolts from hardware kit #57 with 7/16" socket and wrench.



2958 and 2959 brackets

5. Reinstall OE grill and plastic shroud using OE hardware.
6. Layout frame mounts as shown.





2015-20XX Chevrolet 2500-3500 Front

7. Using OE hardware, install Hammerhead Frame mounts on frame as shown. Do not fully tighten.
8. Using Hardware from Kit#62 install bolts, flat washers, lock washers, and weldnut tab (601-56-2498) in bottom of frame mount through bottom OE tow hook bolt hole. (A) Weldnut tab can be inserted through front of Hammerhead frame mount. (B) Do not fully tighten.

You will need:

Qty	Description
2	1/2"-13 x 2" hex head bolt
2	1/2" flat washer
2	1/2" lock washer
2	Weldnut tab (601-56-2498)

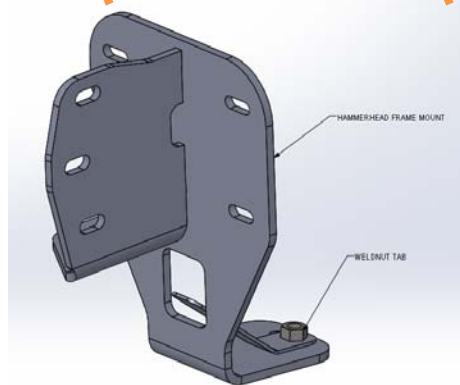

9. Using hardware from kit #62 and weldnut tab 3(qty-2), install Hammerhead bumper on frame mounts. Run bolts toward the center of the vehicle and use weldnut tab 3 on inside. This will make the bolts easier to reach with wrench or socket when tightening.



2015-20XX Chevrolet 2500-3500 Front

You will need:

Qty	Description
6	½"-13 x 2" hex head bolt
12	1/2" flat washer
6	1/2" lock washer
6	1/2"-13 hex head nut
2	Weldnut tab 3 (601-56-2868)

10. Align bumper a minimum of ¼" below headlights. When truck flexes off-road, this distance allows your bumper and body to have clearance. Fully tighten all hardware.



Congratulations! Your bumper installation is now complete.
Thank you for your purchase.