

# 2015-20XX GMC 2500-3500

## FRONT BUMPER INSTALLATION INSTRUCTIONS



## SAFETY

**Know safety, no injury. Know injury, no safety. ~Author Unknown**

- **READ ALL SAFETY INSTRUCTIONS BEFORE INSTALLATION**
  - FOLLOW ALL INSTRUCTIONS FOR PROPER ASSEMBLY
  - WEAR APPROPRIATE EYE PROTECTION
  - EXERCISE CARE WHEN LIFTING COMPONENTS
  - USE APPROPRIATE TORQUE FOR BOLTS
  - BLUE THREAD LOCKING COMPOUND IS RECOMMENDED ON ALL BOLTS

California Proposition 65



**WARNING**

Cancer and Reproductive Harm

[www.P65Warnings.ca.gov](http://www.P65Warnings.ca.gov)

DO NOT PAINT OVER THIS LABEL. REPLACE IF DAMAGED OR LOST

DKB150\_00



## 2015-20XX GMC 2500-3500 Front

<b>Suggested Torque Values For Steel Grade 5 Standard Bolts</b>		
BOLT DIAMETER (INCH)	THREADS PER INCH	TORQUE (POUND - FEET)
1/4	20	7
5/16	18	14
3/8	16	25
7/16	14	40
1/2	13	60
9/16	12	88
5/8	11	120
3/4	10	200
7/8	9	302
1	8	466

<b>Suggested Torque Values For Steel Grade 8.8 Metric Bolts</b>		
BOLT DIAMETER (mm)	THREAD PITCH (mm)	TORQUE (POUND-FEET)
6	1.0	7
8	1.25	16
10	1.5	32
12	1.75	55
14	2.0	88
16	2.0	140
18	2.5	195
20	2.5	275
22	2.5	375
24	3.0	475

### I. PARTS LIST

ITEM NO.	QTY.	PART NUMBER	DESCRIPTION	
1	1	60K-56-0057	HARDWARE KIT #57	-
2	1	60K-56-0062	HARDWARE KIT #62	-
3	1	60P-56-0416	600-56-0416 POLISHED	-
4	4	316-01-0005	1.25" PLUG BT-FLUSH LDPE BLACK	-
5	2	601-56-2498	WELDNUT TAB 1	-
6	2	601-56-2868	WELDNUT TAB 3	-
7	1	601-56-2958	RIGHT BAR MOUNT	-
8	1	601-56-2959	LEFT BAR MOUNT	-
9	1	601-56-3042	RIGHT FRAME MOUNT WELDMENT	-
10	1	601-56-3043	LEFT FRAME MOUNT WELDMENT	-



## 2015-20XX GMC 2500-3500 Front

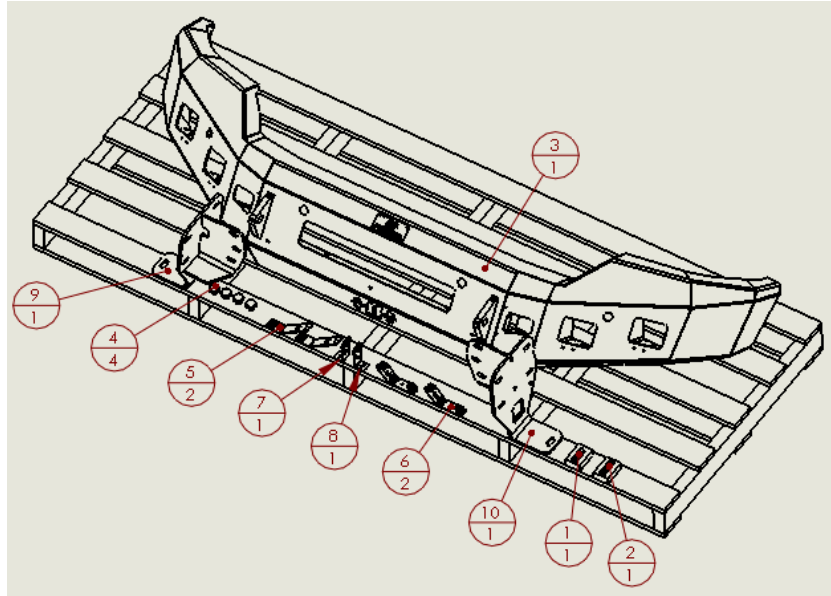

### II. TOOL LIST

1. 3/4" wrench
2. 3/4" socket
3. Flathead screwdriver
4. 10mm socket
5. 15mm socket
6. 18mm socket
7. 18mm wrench

### III. REMOVAL OF OEM BUMPER

1. Using flathead screwdriver, remove 12 plastic retainers in OEM plastic shroud. Gently set aside. It will be reused.

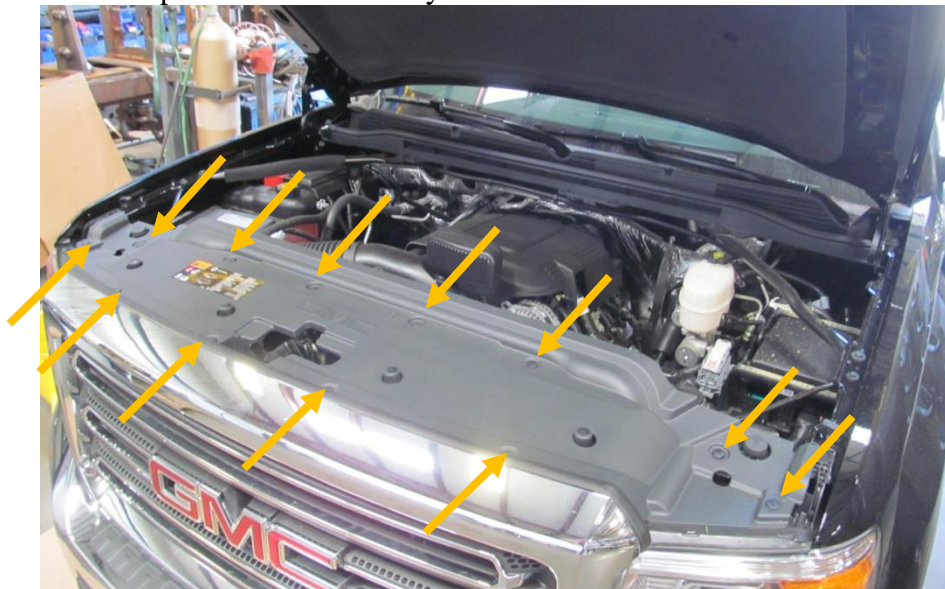



## 2015-20XX GMC 2500-3500 Front

- Using 10mm socket, remove four screws in top of grill.



- Gently pull out on grill to remove. Start at top by pulling up and then out on top tabs. Then pull out on bottom. Gently set aside. It will be reused.

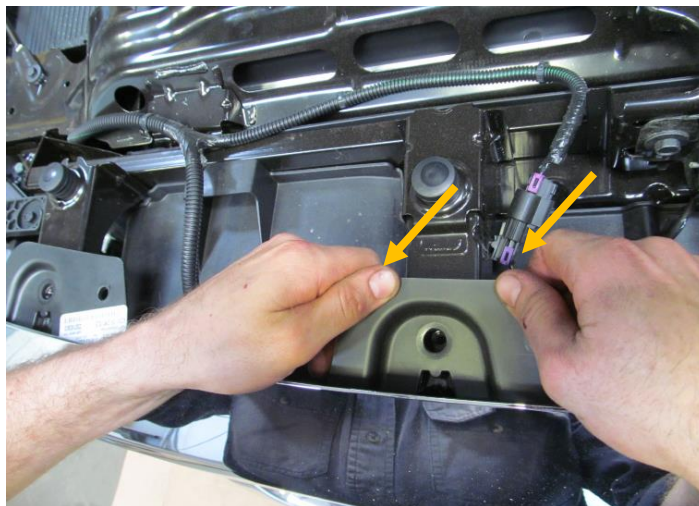

- Using 15mm socket, remove 3 bolts from OEM bumper side brace in front of tire. Set aside. (both sides)







## 2015-20XX GMC 2500-3500 Front

5. Unplug OEM sensor/fog light harness. (if applicable) NOTE: Pull red tab out 1/4" then press plug.



6. Using 18mm socket, remove four bolts attaching OEM bumper to OEM mounts. Set bumper aside.

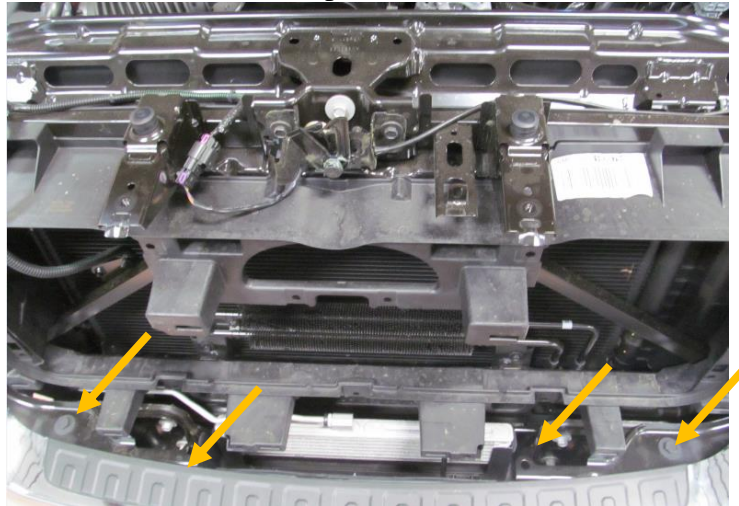

7. Using 15mm socket, remove eight bolts attaching OEM bumper frame mount brackets to frame. Set brackets aside. (Hardware will be reused.)

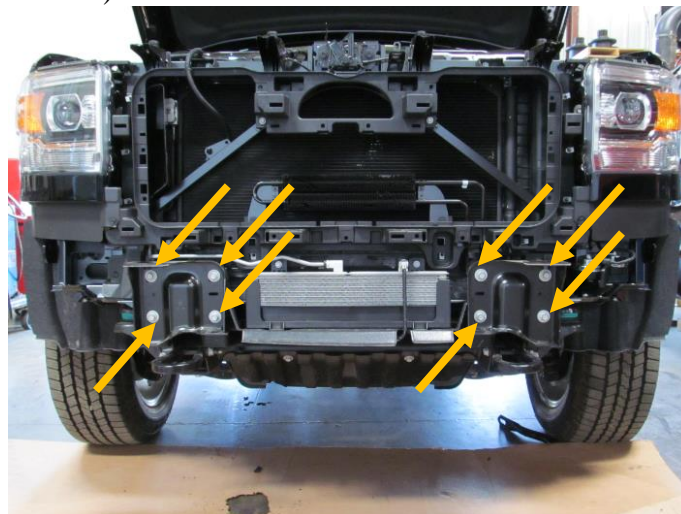



## 2015-20XX GMC 2500-3500 Front

- Using 18mm socket and wrench, remove OEM tow hook. Set tow hook aside. (both sides)

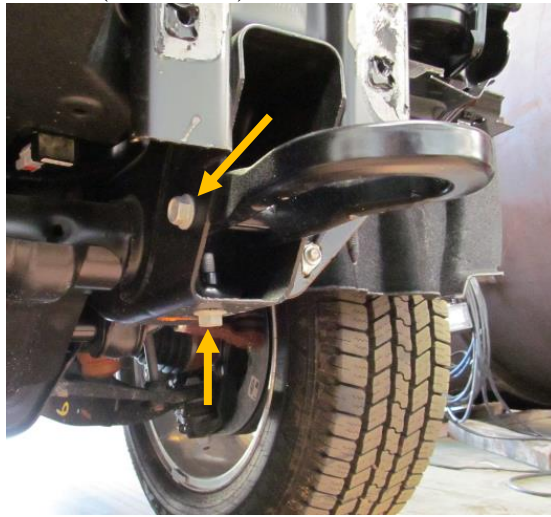

- Remove OEM wiring harness, sensors and grommets from OEM bumper. (if applicable) When removing sensors and grommets, keep them in the same order and orientation left to right that they came out of the truck in. This is very important. Use pic below to keep track of sensors and grommets.

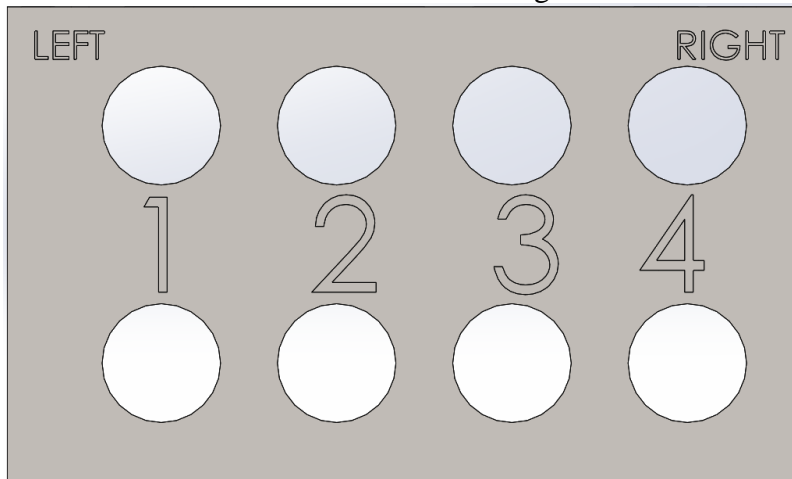

### IV. INSTALLATION OF HAMMERHEAD BUMPER

- If your truck is equipped with sensors, install OEM sensor grommets in Hammerhead bumper. Make sure they are oriented in the same way they were in the OEM bumper.





### 2015-20XX GMC 2500-3500 Front

2. If your truck is not equipped with sensors, install provided plugs in sensor holes.



3. Install all lights in Hammerhead bumper at this time. Use included Bar mount brackets (601-56-2958 and 2959) and Hardware kit #57 to attach 20" bar in bumper to mount in bumper. Use hole in bracket and bumper that works best with your light bar. Tighten bolts from hardware kit #57 with 7/16" socket and wrench.

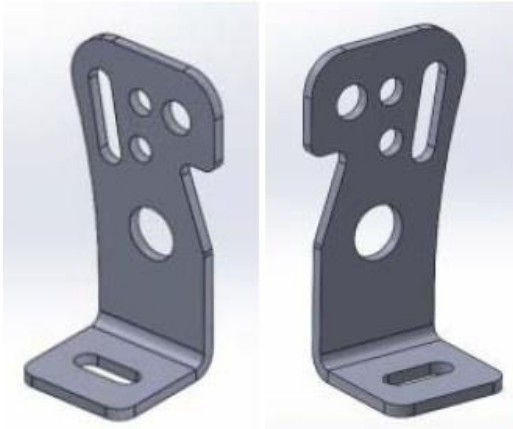

2958 and 2959 brackets

4. Reinstall OEM grill and plastic shroud using OEM hardware.
5. Lay out frame mounts, weldtabs and hardware as shown.





## 2015-20XX GMC 2500-3500 Front

6. Using OEM hardware, install Hammerhead Frame mounts on frame. Do not fully tighten.
7. Using Hardware Kit#62 install two ½”-13x2 bolts, two ½” flat washers, two ½” lock washers, and two weldnut tabs (601-56-2498) in bottom of frame mount through bottom OEM tow hook bolt hole (A). Weldnut tab can be inserted through front of Hammerhead frame mount (B). Do not fully tighten.

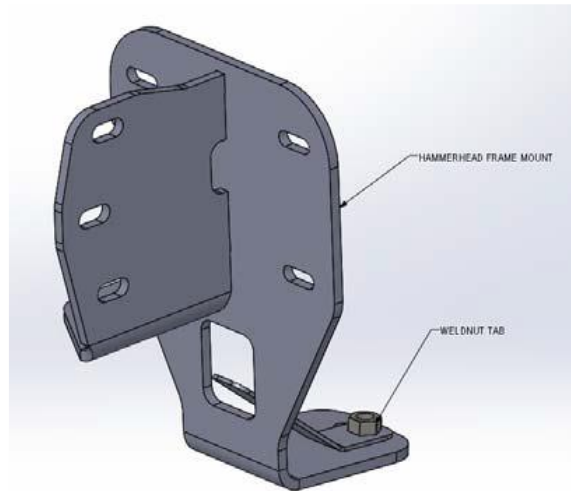
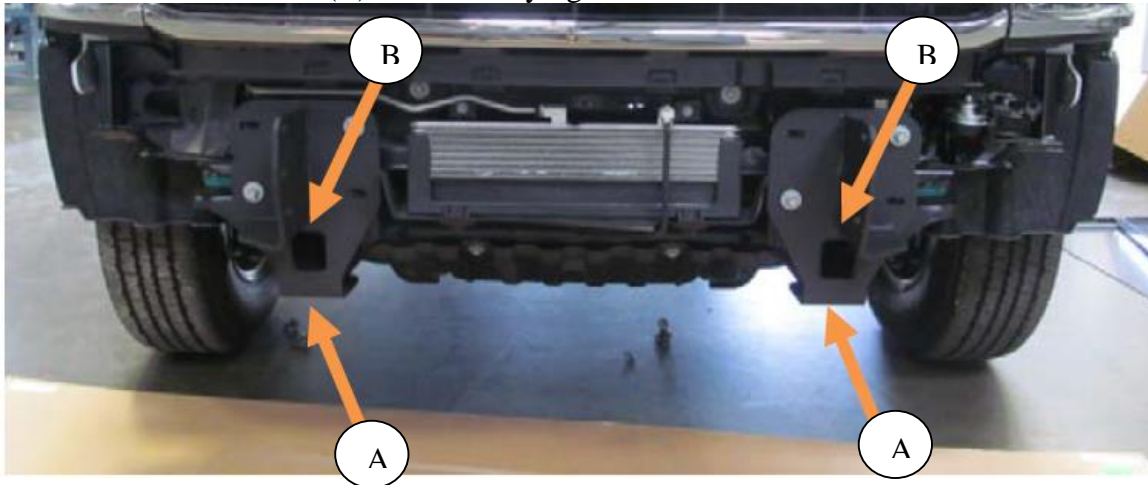

8. Install Hammerhead bumper on frame mounts using six ½”-13x2” bolts, six ½” flat washers, and six ½” lock washers from Hardware Kit# 62 and two weldnut tab 3s (601-56-2868). You will need a ¾” wrench and socket. Install bolts from inside pointing out. Place weld tab 3 on outside of shackle mounts. Do not fully tighten.
9. Align bumper a minimum of ¼” below headlights. When truck flexes off-road, this distance allows your bumper and body to have clearance. Fully tighten all hardware.





2015-20XX GMC 2500-3500 Front



Congratulations! Your bumper installation is now complete.  
Thank you for your purchase.