

# 2014-20XX CHEVY/GMC 1500

## REAR FLUSH MOUNT BUMPER INSTALLATION INSTRUCTION



## SAFETY

**Know safety, no injury. Know injury, no safety. ~Author Unknown**

- **READ ALL SAFETY INSTRUCTIONS BEFORE INSTALLATION**
  - FOLLOW ALL INSTRUCTIONS FOR PROPER ASSEMBLY
  - WEAR APPROPRIATE EYE PROTECTION
  - EXERCISE CARE WHEN LIFTING COMPONENTS
  - USE APPROPRIATE TORQUE FOR BOLTS
  - BLUE THREAD LOCKING COMPOUND IS RECOMMENDED ON ALL BOLTS





2014-20XX CHEVY/GMC 1500 REAR BUMPER – FLUSH MOUNT

<b>Suggested Torque Values For Steel Grade 5 Standard Bolts</b>		
BOLT DIAMETER (INCH)	THREADS PER INCH	TORQUE (POUND - FEET)
1/4	20	7
5/16	18	14
3/8	16	25
7/16	14	40
1/2	13	60
9/16	12	88
5/8	11	120
3/4	10	200
7/8	9	302
1	8	466

<b>Suggested Torque Values For Steel Grade 8.8 Metric Bolts</b>		
BOLT DIAMETER (mm)	THREAD PITCH (mm)	TORQUE (POUND-FEET)
6	1.0	7
8	1.25	16
10	1.5	32
12	1.75	55
14	2.0	88
16	2.0	140
18	2.5	195
20	2.5	275
22	2.5	375
24	3.0	475

**I. PARTS LIST**

ITEM NO.	QTY.	PART NUMBER	DESCRIPTION
1	2	307-07-0008	12V COOL WHITE LED 120DEG BLK
2	4	307-09-0135	BUTT SPLICE 22/16 RED, HEATSINK
3	4	316-01-0005	1.25" PLUG BT-FLUSH LDPE BLACK
4	1	443-01-0086	LICENSE PLATE MOUNTING KIT
5	1	601-56-2122	DRIVER SIDE FRAME MOUNT WELDMENT
6	1	601-56-2123	PASSENGER SIDE FRAME MOUNT WELDMENT
7	1	60K-56-0001	HARDWARE KIT #1
8	1	60K-56-0102	HARDWARE KIT #102
9	1	60P-56-0481	600-56-0481 POLISHED



## 2014-20XX CHEVY/GMC 1500 REAR BUMPER – FLUSH MOUNT

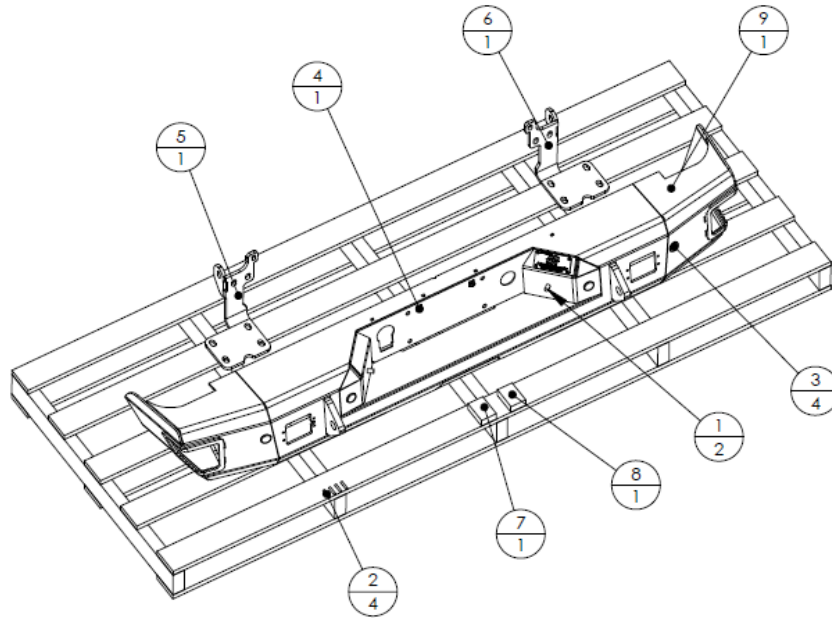

### II. TOOL LIST

1. 10mm socket
2. 13mm socket
3. 15mm socket
4. 18mm socket
5. 21mm socket
6. 21mm wrench
7.  $\frac{3}{4}$ " wrench
8.  $\frac{3}{4}$ " socket

### III. REMOVAL OF OEM BUMPER

1. Unplug OEM trailer connector

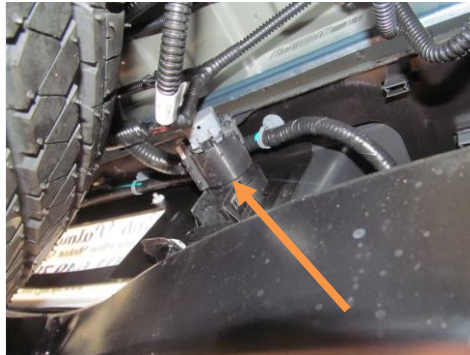

2. Unplug OEM license plate and sensor wiring harnesses



## 2014-20XX CHEVY/GMC 1500 REAR BUMPER – FLUSH MOUNT



3. Remove two OEM bolts behind tag area with 13mm socket.
4. Remove two OEM frame nuts with 18mm socket. (orange arrow) Remove one OEM frame bolt with 15mm socket (yellow arrow). (both sides)



5. Remove bolt in receiver hitch with 21mm socket. (both sides)

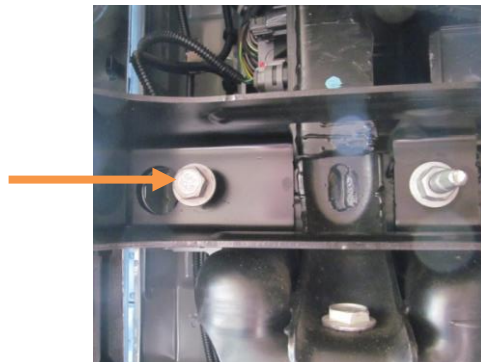

6. Loosen two receiver mount bolts. Hint: Use a 21mm wrench to hold the nut and use a 10mm socket to turn the bolt.



## 2014-20XX CHEVY/GMC 1500 REAR BUMPER – FLUSH MOUNT

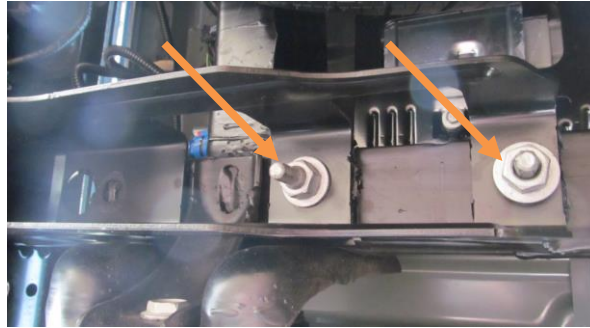

7. After receiver hitch is loose, remove OEM bumper and set on cardboard.
8. Remove OEM trailer plug by pushing in on clips.

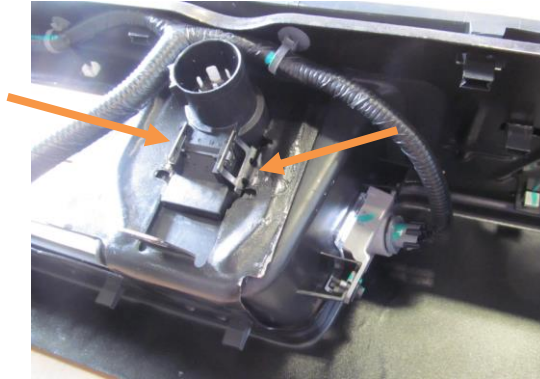

9. Unplug OEM license plate lights.

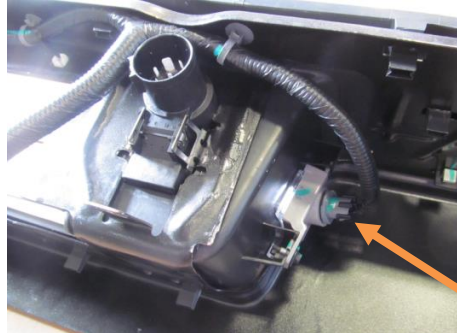

10. Remove OEM spare tire access housing. Pry back metal fingers on ring and remove plastic insert.

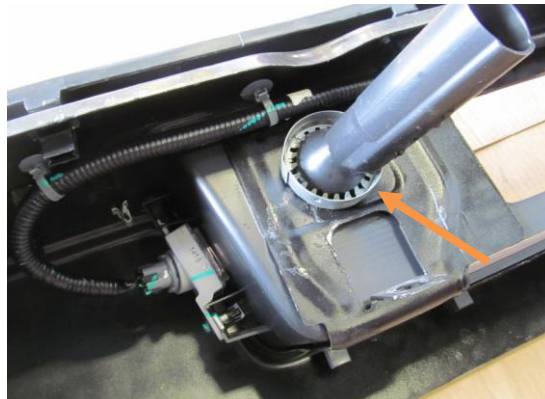



## 2014-20XX CHEVY/GMC 1500 REAR BUMPER – FLUSH MOUNT

11. Remove OEM wiring harness from bumper. Be careful not to damage plastic tabs; they will be reused.
12. Remove sensors and grommets one at a time and place in Hammerhead bumper in corresponding holes.

### IV. INSTALLATION OF HAMMERHEAD BUMPER

1. Install provided license plate lights in Hammerhead bumper.
2. Install OEM trailer plug in Hammerhead bumper. Ensure metal tabs are fully engaged on bumper surface. You may need to pull out on them gently.



3. Install OEM spare tire access housing.



4. Install OEM wiring harness on Hammerhead bumper and plug in tag lights and sensors. Use red butt connectors to attach them to OE wiring harness to Hammerhead license plate lights. Test lights before crimping connectors.
5. Install flush mount LED lights in bumper using manufacturer provided hardware.
6. Install Hammerhead Frame mount weldments with the flanges with four slots pointing outward. (601-56-2122 and 601-56-2123) Use hardware kit #102 for this step. Use three ½”-13 x 2” bolts, flat washers, lock washers, and ½” nuts for the larger bolt holes. Use one 3/8”-16 x 1.5” bolt, flat washer, lock washer, and 3/8”-16 nut for the smaller forward most hole. These mounts will set the in and out adjustment of the bumper. Both sides.



## 2014-20XX CHEVY/GMC 1500 REAR BUMPER – FLUSH MOUNT

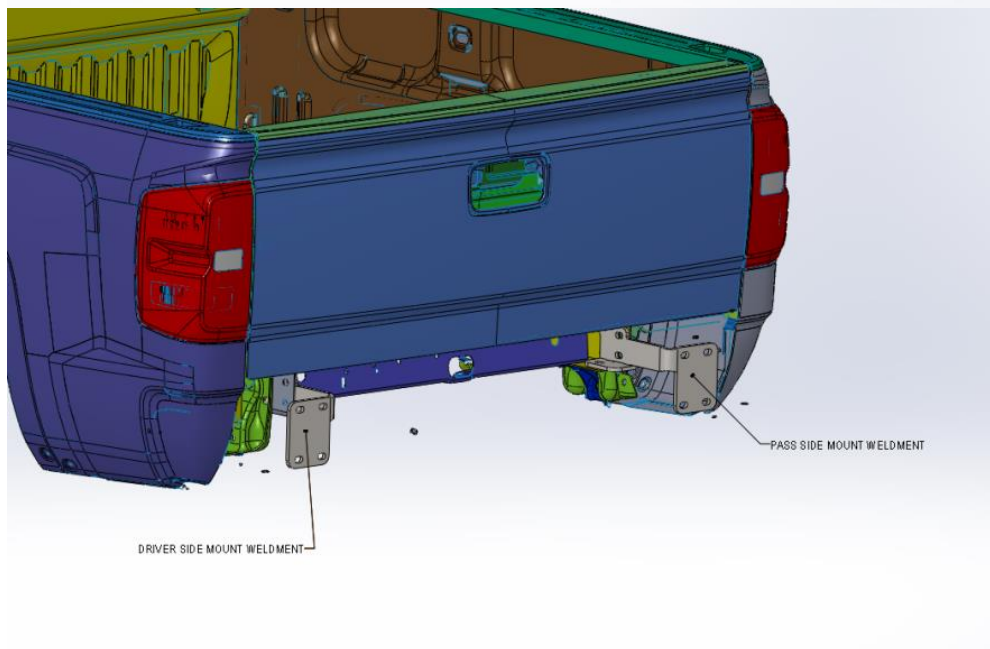
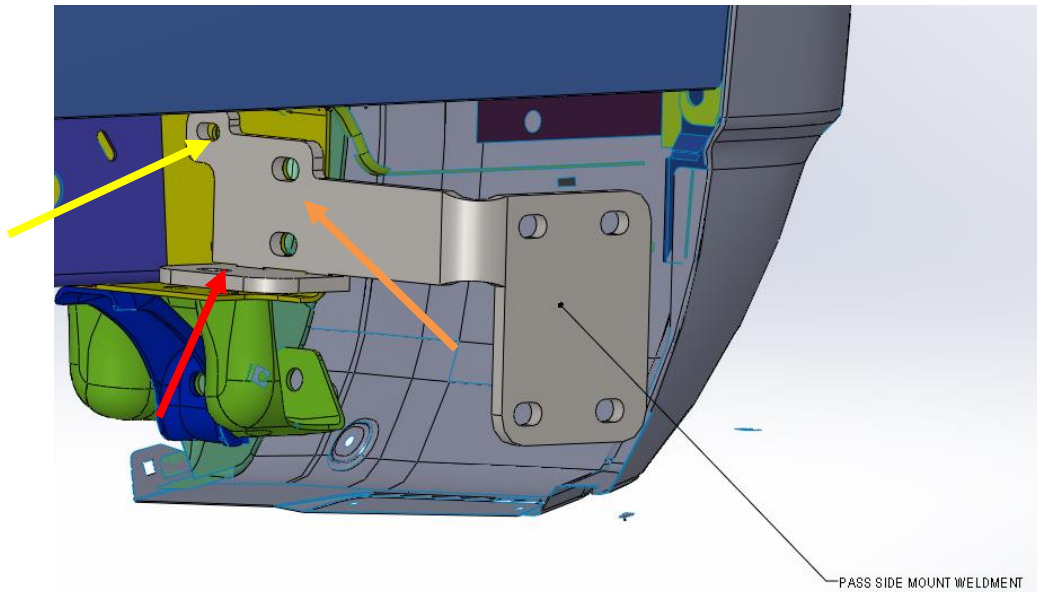

7. Use hardware kit #1 for this step. Install bumper on Hammerhead frame mounts with eight ½"-13 x 2" bolts, 16 flat washers, eight lock washers, and eight nuts. These mounts will set the left to right and the up and down adjustment of the bumper. Make sure to check tailgate clearance before tightening bolts.



2014-20XX CHEVY/GMC 1500 REAR BUMPER – FLUSH MOUNT

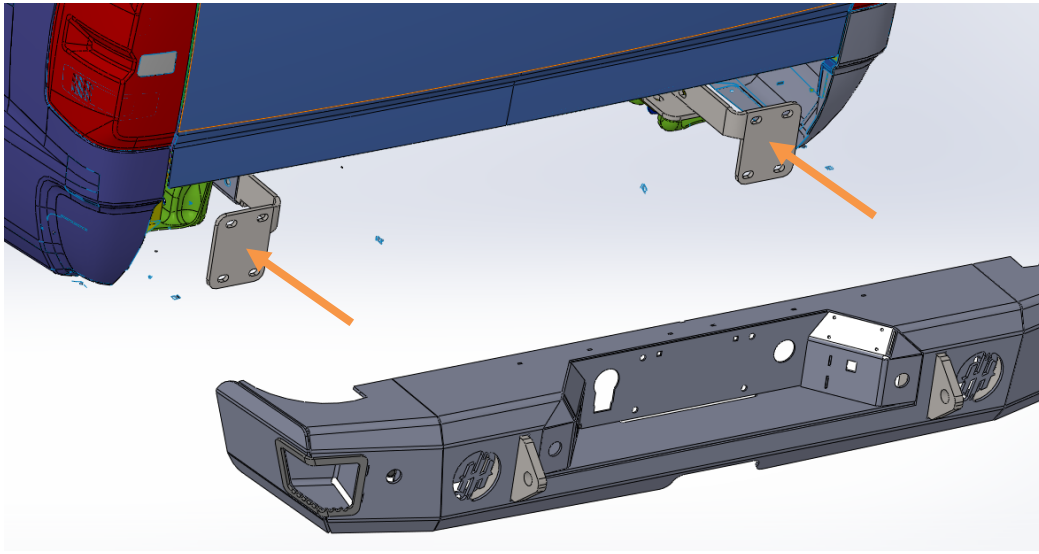

Congratulations! Your product installation is now complete.  
Thank you for your purchase.