

2018-20XX Jeep Wrangler JL

RAVAGER STUBBY FRONT BUMPER INSTALLATION INSTRUCTIONS



SAFETY

Know safety, no injury. Know injury, no safety. ~Author Unknown

- **READ ALL SAFETY INSTRUCTIONS BEFORE INSTALLATION**
 - FOLLOW ALL INSTRUCTIONS FOR PROPER ASSEMBLY
 - WEAR APPROPRIATE EYE PROTECTION
 - EXERCISE CARE WHEN LIFTING COMPONENTS
 - USE APPROPRIATE TORQUE FOR BOLTS
 - BLUE THREAD LOCKING COMPOUND IS RECOMMENDED ON ALL BOLTS
 - CHECK TORQUE AFTER FIRST 100 MILES

California Proposition 65



WARNING

Cancer and Reproductive Harm

www.P65Warnings.ca.gov

DO NOT PAINT OVER THIS LABEL. REPLACE IF DAMAGED OR LOST

DKB150_00



2018-20XX Jeep JL Ravager Stubby Front Bumper

Suggested Torque Values For Steel Grade 5 Standard Bolts		
BOLT DIAMETER (INCH)	THREADS PER INCH	TORQUE (POUND - FEET)
1/4	20	7
5/16	18	14
3/8	16	25
7/16	14	40
1/2	13	60
9/16	12	88
5/8	11	120
3/4	10	200
7/8	9	302
1	8	466

Suggested Torque Values For Steel Grade 8.8 Metric Bolts		
BOLT DIAMETER (mm)	THREAD PITCH (mm)	TORQUE (POUND-FEET)
6	1.0	7
8	1.25	16
10	1.5	32
12	1.75	55
14	2.0	88
16	2.0	140
18	2.5	195
20	2.5	275
22	2.5	375
24	3.0	475

I. Parts List

ITEM NO.	QTY.	PART NUMBER	DESCRIPTION
1	1	601-56-3744	3048MM LENGTH FOAM ROLL
2	2	601-56-4427	ACCENT PLATE
3	1	601-56-4428	MIDDLE ACCENT PLATE
4	1	60K-56-0017	HARDWARE KIT #17
5	1	60K-56-0163	HARDWARE KIT #163
6	1	60P-56-0774	JP JL RAVAGER STUBBY FRONT BUMPER W/ PLATES



2018-20XX Jeep JL Ravager Stubby Front Bumper

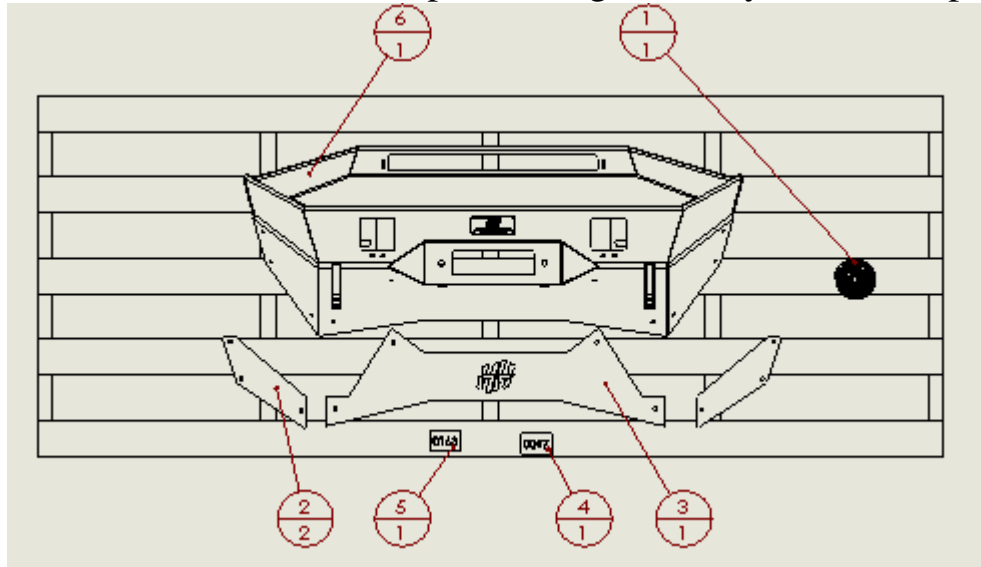

REMOVE CONTENTS FROM BOX AND VERIFY ALL PARTS ARE PRESENT.
If there are any questions, call 1-855-HHTOUGH or email
HHORDERS@hammerheadarmor.com

II. TOOL LIST

1. 18mm socket
2. 16mm socket
3. 8mm socket
4. 3/4" socket
5. Torx 20
6. 7/16 wrench

III. REMOVAL OF OEM BUMPER





2018-20XX Jeep JL Ravager Stubby Front Bumper

1. Remove 8 plastic clips from front of OE “skid plate”. Using the 8mm socket, remove the two bolts from the bottom then remove the skid plate.

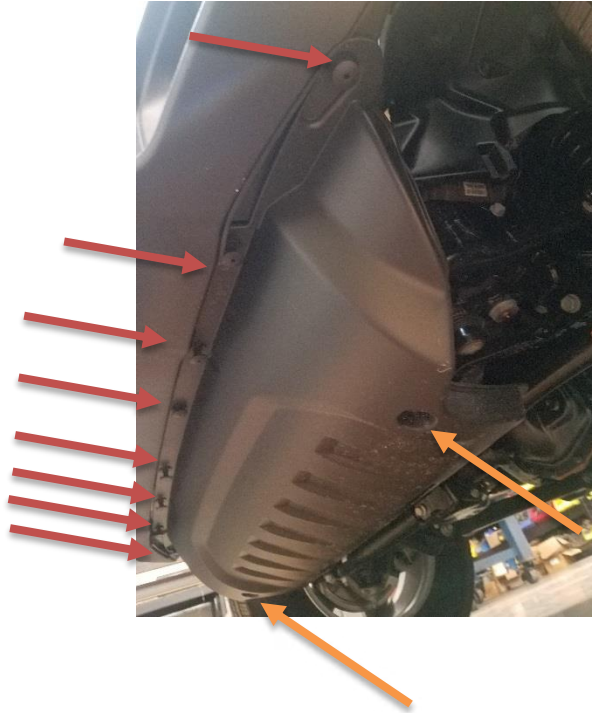

2. Remove the two bolts from the backing plate with the 15mm socket then remove the plate.



3. There is two nuts on the outside of the frame and the inside of the frame for a total of 8. Remove these with the 18mm socket.



2018-20XX Jeep JL Ravager Stubby Front Bumper



4. Unplug the fog lights. The plug is located on the left side next to the body mount



5. Remove the 2 plastic clips on the front top trim piece.





2018-20XX Jeep JL Ravager Stubby Front Bumper

6. Remove the OE bumper.



7. Remove the plastic cover on each side of the front bumper using the torx 20. There are 7 screws.

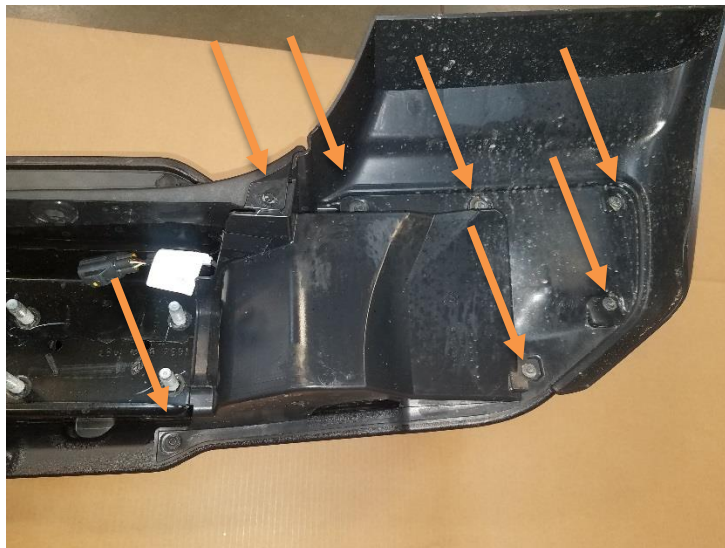



2018-20XX Jeep JL Ravager Stubby Front Bumper

8. Depending on what package you have your fog light mounting will be different. If you have the Rubicon there are 2 6mm bolts you will remove with a 10mm socket. If you have the Sahara there are 4 screws you will remove with a Torx 20. If you have the sport you will remove 3 screws with a Torx 20. Unplug and remove the fog lights.



9. Remove all 6 plastic clips from the top trim and remove the top trim.





2018-20XX Jeep JL Ravager Stubby Front Bumper

10. Remove the 8 push nuts from the main 8 bolts in the bumper.



11. Remove the 4 bolts holding on the metal plate with a 15mm socket.
Remove the metal plate and set aside.





2018-20XX Jeep JL Ravager Stubby Front Bumper

12. Remove the wiring harness from the front bumper.



IV. INSTALLATION OF HAMMERHEAD BUMPER

1. Line the back of the accent plates with the provided foam as shown below. Use the .25" bolts from hardware kit #163 to install the accent plates. (These plates can be painted if you desire to do so)

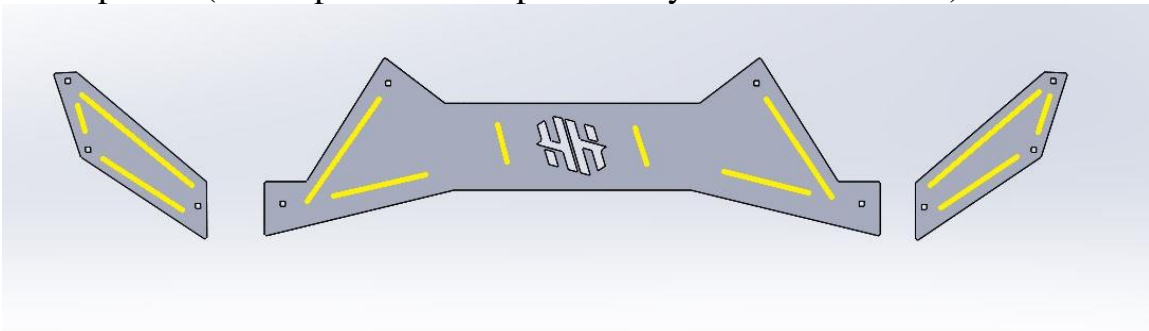



2018-20XX Jeep JL Ravager Stubby Front Bumper

2. Install four ½"-13 x 1.5" carriage head bolts in bumper with push nuts. Do this for both sides

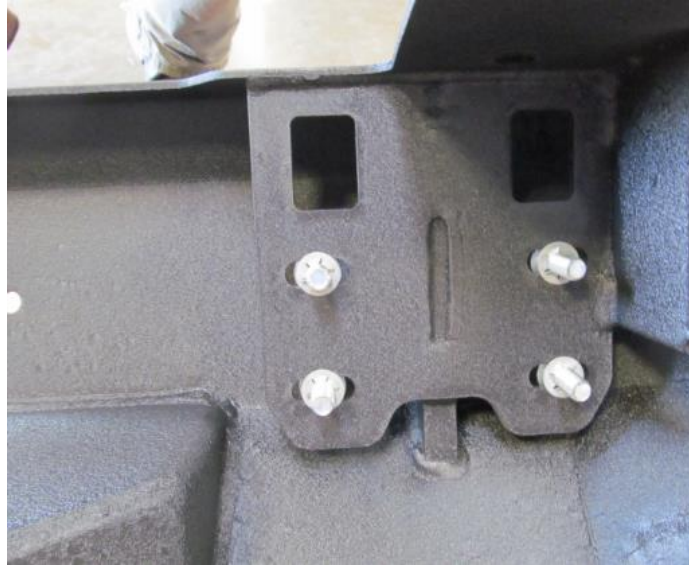

2. Place bumper on frame mounts and use the provided 8 ½" nuts, 8 ½" washers and 8 ½" lock washers to secure the bumper to the frame.
3. Align bumper and torque all bolts to spec with a ¾" socket.



CONGRATULATIONS!

Your hammerhead stubby front bumper installation is now complete.
Thank you for your purchase.