

2018-20XX FORD F-150

Low Pro No Brushguard Bumper

INSTALLATION INSTRUCTIONS



SAFETY

Know safety, no injury. Know injury, no safety. ~Author Unknown

If there are any questions, call 1-855-HHTOUGH

- **READ ALL SAFETY INSTRUCTIONS BEFORE INSTALLATION**
 - FOLLOW ALL INSTRUCTIONS FOR PROPER ASSEMBLY
 - WEAR APPROPRIATE EYE PROTECTION
 - EXERCISE CARE WHEN LIFTING COMPONENTS
 - USE APPROPRIATE TORQUE FOR BOLTS

SUGGESTED TORQUE VALUES FOR STEEL GRADE SAE 5 BOLTS

BOLT DIAMETER (INCH)	TREADS PER INCH	TORQUE (POUND-FEET)
1/4	20	7
5/16	18	14
3/8	16	25
7/16	14	40
1/2	13	60
9/16	12	88
5/8	11	120
3/4	10	200
7/8	9	302
1	8	466

I. PARTS LIST

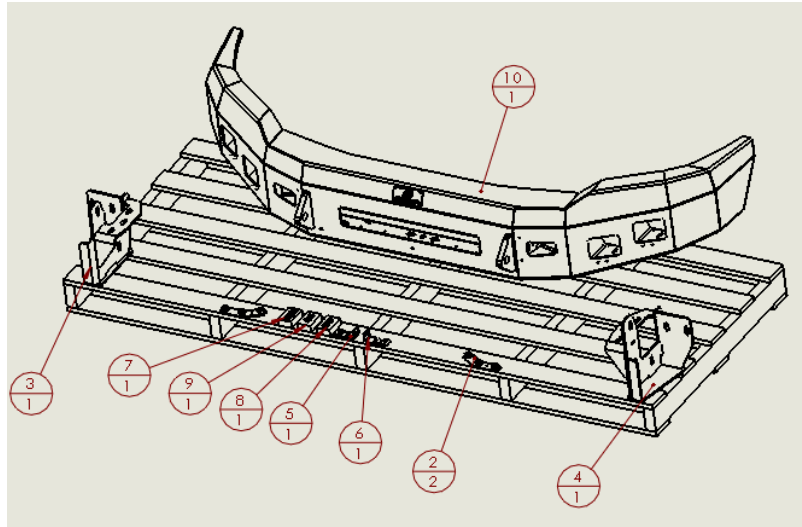

ITEM NO.	QTY.	PART NUMBER	DESCRIPTION	
1	3	318-12-0005	0.188" X 0.125" AL POP RIVET	-
2	2	601-5-6-2868	WELDN UT TAB 3	-
3	1	601-5-6-2896	RIGHT FRAME MOUNT WELD MENT	-
4	1	601-5-6-2897	LEFT FRAME MOUNT WELD MENT	-
5	1	601-5-6-2958	RIGHT BAR MOUNT	-
6	1	601-5-6-2959	LEFT BAR MOUNT	-
7	1	60K-56-0053	HARDWARE KIT #53	-
8	1	60K-56-0057	HARDWARE KIT #57	-
9	1	60K-56-0148	HARDWARE KIT #148	-
10	1	60P-56-0802	600-5-6-0802 POLISHED	-

II. TOOL LIST

1. Basic tool set
2. Blue masking tape
3. 7/16" socket
4. 7/16" wrench
5. 15mm socket
6. 21mm socket
7. 3/4" socket
8. 3/4" wrench
9. Trim tool or flathead screwdriver

III. REMOVAL OF BUMPER

1. Disconnect battery.
2. Using blue masking tape, mask along the profile of your truck above the bumper. This will help protect your truck from accidental scratches.
3. Unplug the fog lights and adaptive cruise control (if applicable).
4. Using a trim tool or flathead screwdriver, remove plastic covers from above tow hooks (both sides)



5. Using a 7/16" socket, remove the Adaptive cruise control unit (if applicable).

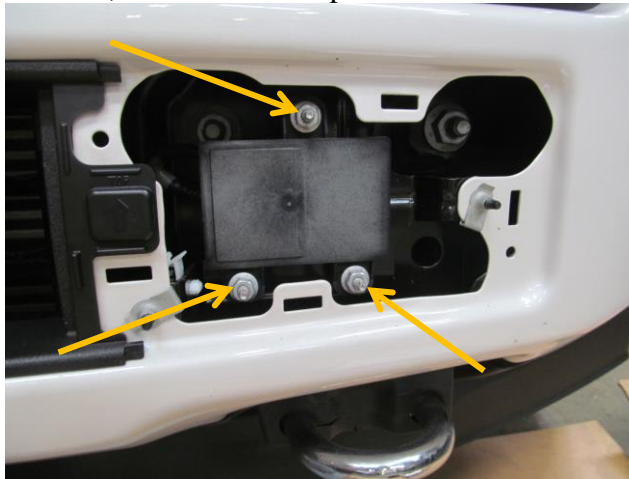

6. Using a 21mm socket, remove 1 nut from the back side of the bumper (Both Sides)

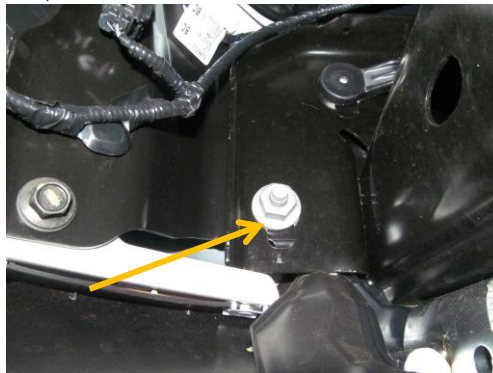

7. Using a 21mm socket, remove the 2 front nuts attaching the OE bumper to the truck (Both Sides). Once these are removed, pull the bumper away from the truck and place it out of the way. Keep the nuts and bolt strips, they will be used again.

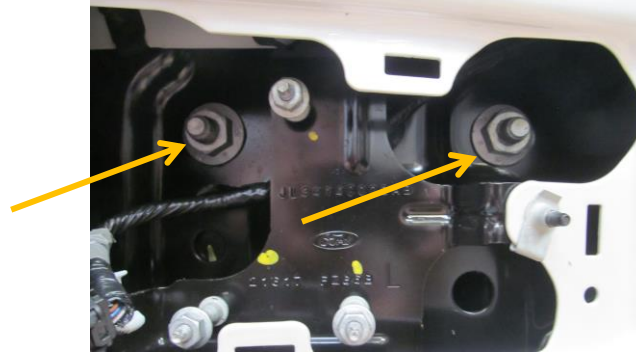

8. Remove OE tow hook shroud by pulling away from the truck. (Both sides)



9. Using a trim tool or flathead screwdriver, remove the air shroud from the front of the truck.



- Using a 15mm socket, remove 2 bolts attaching OE tow hook to frame. Set tow hook aside (both sides). Keep the bolts and nut strips, they will be used again.

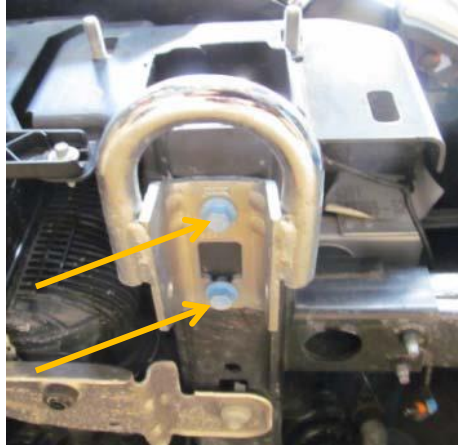

IV. INSTALLATION OF HAMMERHEAD BUMPER

- Lay bumper face down on a carpeted surface or a piece of cardboard. Install all lights in bumper with brackets and hardware provided by light manufacturer.
- Layout frame mounts, OE bolt strips, OE nut strips, and hardware from kit #148 as shown:



- Using a 15mm socket, 21mm socket, and a 3/4" socket, install Hammerhead frame mounts on frame as shown. Do not fully tighten.





4. Using a hoist or a few friends, attach bumper to frame mounts hardware kit #53, and 1 weld nut tab per side. Start all bolts before aligning bumper. Align bumper a minimum of ¼” below plastic fascia. When truck flexes off-road, this distance allows your bumper and body to have clearance. Tighten bolts with ¾” socket and wrench. Tighten frame mount bolts at this time.



Congratulations! Your product installation is now complete.
Thank you for your purchase.