

2016-20XX NISSAN TITAN XD LOW PRO SHEET METAL BRUSHGUARD

FRONT BUMPER INSTALLATION INSTRUCTIONS



SAFETY

Know Safety, no injury. Know injury, no safety. ~Author Unknown
If there are any questions, call 1-855-HHTOUGH

- **READ ALL SAFETY INSTRUCTIONS BEFORE INSTALLATION**
 - FOLLOW ALL INSTRUCTIONS FOR PROPER ASSEMBLY
 - WEAR APPROPRIATE EYE PROTECTION
 - EXERCISE CARE WHEN LIFTING COMPONENTS
 - USE APPROPRIATE TORQUE FOR BOLTS
 - BLUE THREAD LOCKING COMPOUND IS RECOMMENDED ON ALL BOLTS

SUGGESTED TORQUE VALUES FOR STEEL GRADE SAE 5 BOLTS

BOLT DIAMETER (INCH)	TREADS PER INCH	TORQUE (POUND-FEET)
1/4	20	7
5/16	18	14
3/8	16	25
7/16	14	40
1/2	13	60
9/16	12	88
5/8	11	120
3/4	10	200
7/8	9	302
1	8	466

I. PARTS LIST

ITEM NO.	QTY.	PART NUMBER	DESCRIPTION
1	2	601-56-2868	WELDNUT TAB 3
2	1	601-56-2958	RIGHT BAR MOUNT
3	1	601-56-2959	LEFT BAR MOUNT
4	1	601-56-4995	RIGHT MOUNT WELDMENT
5	1	601-56-4996	LEFT MOUNT WELDMENT
6	1	60A-56-0888	600-56-0888 ASSEMBLED
7	1	60K-56-0057	HARDWARE KIT #57
8	1	60K-56-0058	HARDWARE KIT #58

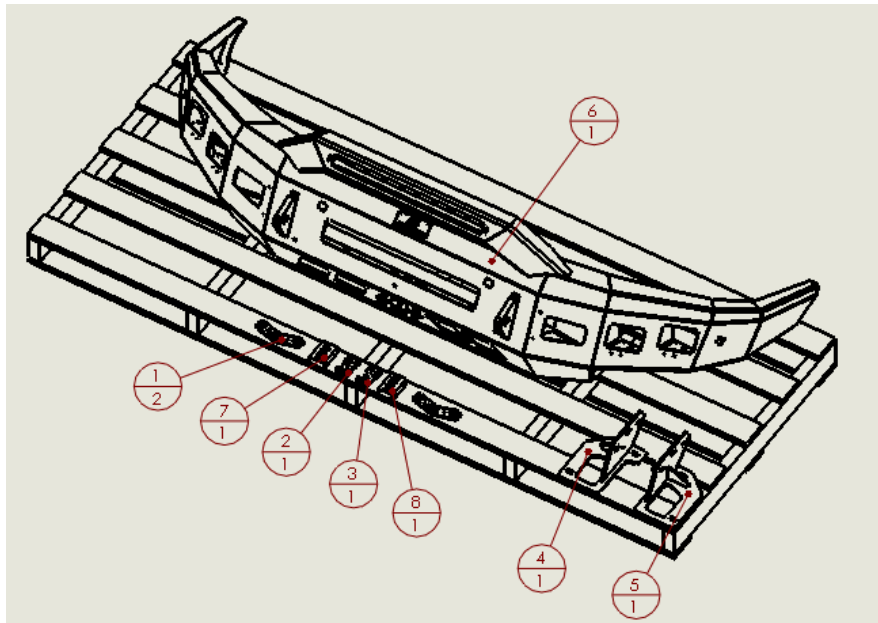

REMOVE CONTENTS FROM BOX AND VERIFY ALL PARTS ARE PRESENT.

If there are any questions, call 1-855 HHTOUGH or email HHORDERS@hammerheadarmor.com

II. TOOL LIST

1. A Good Friend
2. Basic Tool Kit
3. Blue Masking Tape
4. Trim Tool
5. 10mm Socket
6. 12mm Socket
7. 14mm Socket
8. 3/4" Socket
9. 3/4" Wrench

III. VEHICLE PREPARATION

1. Park vehicle on level surface.
2. Engage parking brake and disconnect battery.
3. Using blue masking tape, mask along the profile of your truck above the bumper. This will help protect your truck from any accidental scratches.

IV. REMOVAL OF OE BUMPER

1. Disconnect the OE fog light wiring harnesses from each side of the bumper



2. Disconnect the main sensor wiring harness. This connection is located next to the right side fog light.



- Using a 12mm socket, remove the mount bolts attaching the bumper side supports to the frame. (Both sides)



- Using a 14mm socket, remove the bumper mounting bolt located in the frame extension of the vehicle. (Both sides)

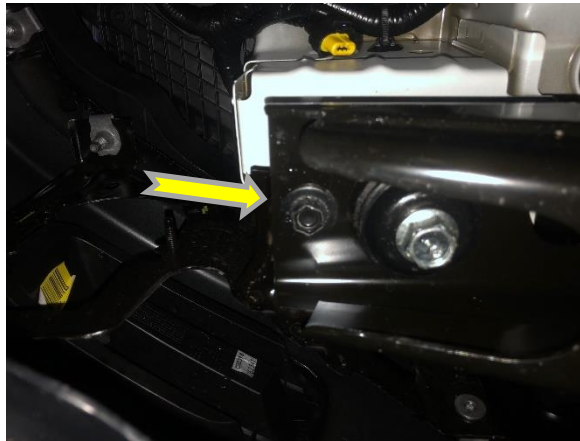

- Using a 17mm socket, remove the tow hook mount bolts and remove the tow hook. Set it aside, it will not be used again. (Both Sides)
- Remove the plastic covers located in the bumper above the tow hooks by pulling away from the front of the vehicle. Disconnect the sensor (if applicable).



- Using a 14mm socket, remove the 2 OE bumper mounting bolts. (Both Sides) Set these 2 bolts aside, they will be used again.



- Using a 10mm socket and a trim tool, remove the plastic cover located on the underside of the bumper, right above the tow hook locations.

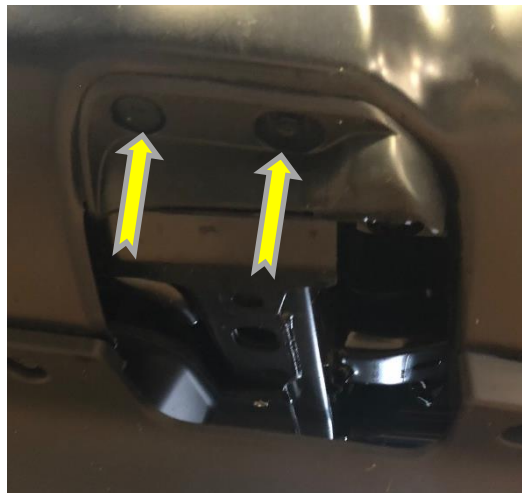

- Using a 14mm socket, remove the bolt behind the plastic cover that was removed (Both Sides). Set this bolt aside, it will be used again.
- With the help of a friend, remove the OE bumper from the truck. The side supports have a hook that fit into the frame which you will have to release. Set the OE bumper aside.
- Remove the sensors, grommets, and sensor wiring harness from the OE bumper. **Be sure to note the position of the grommets, so that they can be installed in the correct locations on your new Hammerhead bumper.**

V. INSTALLATION OF HAMMERHEAD BUMPER

1. Lay bumper face down on a carpeted surface or piece of cardboard. Install winch and all lights in bumper using brackets and hardware provided by light manufacturer.
2. Install the OE sensor grommets, sensors, and sensor wiring harness into the bumper.
3. Layout Frame Mounts and OE hardware as shown.



4. Using a 14 mm socket or wrench, attach the frame mounts to the frame of the truck. Do not fully tighten.



5. Using a hoist or a few friends, attach bumper to frame mounts using hardware kit #58. Start all bolts before aligning bumper. Leave a minimum of 3/8" space between bumper and truck body. When the truck flexes off-road, this distance allows your bumper and truck body to have clearance. Tighten bolts with 3/4" socket and wrench. Tighten frame mount bolts at this time using a 14mm wrench or socket.

**Congratulations! Your Installation is now complete.
Thank You for your purchase!**