

2016-20XX NISSAN TITAN WINCH SHEET METAL BRUSHGUARD

FRONT BUMPER INSTALLATION INSTRUCTIONS



SAFETY

Know Safety, no injury. Know injury, no safety. ~Author Unknown
If there are any questions, call 1-855-HHTOUGH

- **READ ALL SAFETY INSTRUCTIONS BEFORE INSTALLATION**
 - FOLLOW ALL INSTRUCTIONS FOR PROPER ASSEMBLY
 - WEAR APPROPRIATE EYE PROTECTION
 - EXERCISE CARE WHEN LIFTING COMPONENTS
 - USE APPROPRIATE TORQUE FOR BOLTS
 - BLUE THREAD LOCKING COMPOUND IS RECOMMENDED ON ALL BOLTS

California Proposition 65



WARNING

Cancer and Reproductive Harm

www.P65Warnings.ca.gov

DO NOT PAINT OVER THIS LABEL. REPLACE IF DAMAGED OR LOST

DKB150_00



600-56-0904

Suggested Torque Values For Steel Grade 5 Standard Bolts		
BOLT DIAMETER (INCH)	THREADS PER INCH	TORQUE (POUND - FEET)
1/4	20	7
5/16	18	14
3/8	16	25
7/16	14	40
1/2	13	60
9/16	12	88
5/8	11	120
3/4	10	200
7/8	9	302
1	8	466

Suggested Torque Values For Steel Grade 8.8 Metric Bolts		
BOLT DIAMETER (mm)	THREAD PITCH (mm)	TORQUE (POUND- FEET)
6	1.0	7
8	1.25	16
10	1.5	32
12	1.75	55
14	2.0	88
16	2.0	140
18	2.5	195
20	2.5	275
22	2.5	375
24	3.0	475

I. PARTS LIST

ITEM NO.	QTY	PART NUMBER	DESCRIPTION	
1	2	601-56-2868	WELDNUT TAB 3	-
2	1	601-56-5177	LEFT MOUNT WELDMENT	-
3	1	601-56-5178	RIGHT FRAME MOUNT WELDMENT	-
4	1	60A-56-0904	600-56-0904 ASSEMBLED	-
5	1	60K-56-0058	HARDWARE KIT #58	-
6	2	60K-56-0188	HARDWARE KIT #188	-

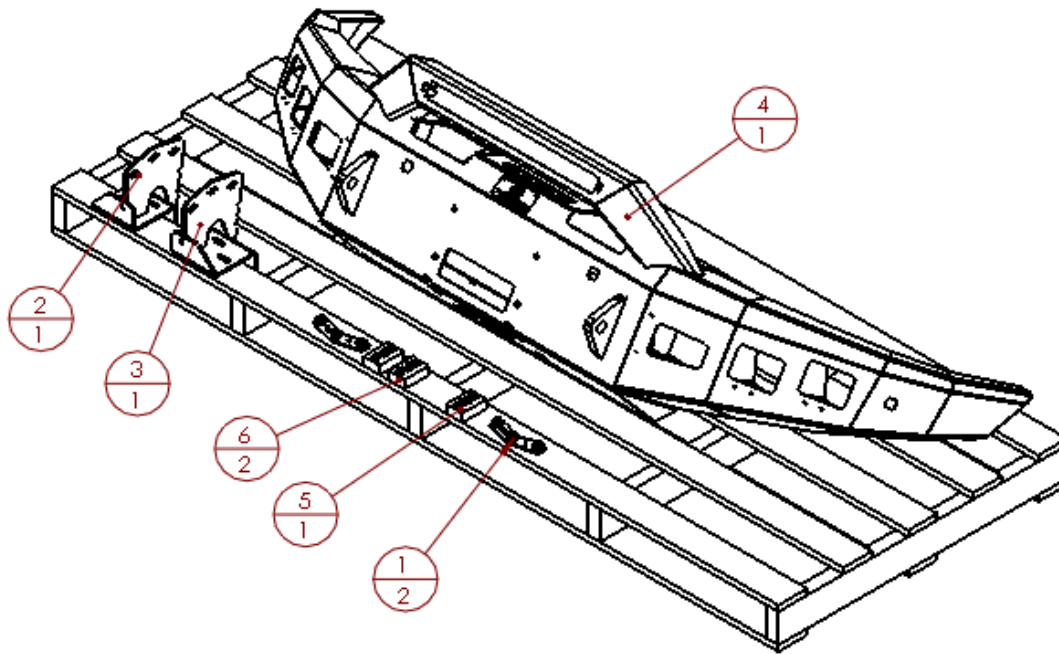

REMOVE CONTENTS FROM BOX AND VERIFY ALL PARTS ARE PRESENT.

If there are any questions, call 1-855 HHTOUGH or email HHORDERS@hammerheadarmor.com

II. TOOL LIST

1. A Good Friend
2. Basic Tool Kit
3. Blue Masking Tape
4. Trim Tool
5. 12mm Socket
6. 14mm Socket
7. 17mm Socket
8. 3/4" Socket
9. 3/4" Wrench

III. VEHICLE PREPARATION

1. Park vehicle on level surface.
2. Engage parking brake and disconnect battery.
3. Using blue masking tape, mask along the profile of your truck above the bumper. This will help protect your truck from any accidental scratches.

IV. REMOVAL OF OE BUMPER

1. Disconnect the OE fog light wiring harnesses from each side of the bumper



2. Disconnect the main sensor wiring harness. This connection is located next to the right side fog light.



3. Using a 12mm socket, remove the mount bolts attaching the bumper side supports to the frame. These supports are located in front of the front tires. (Both sides)

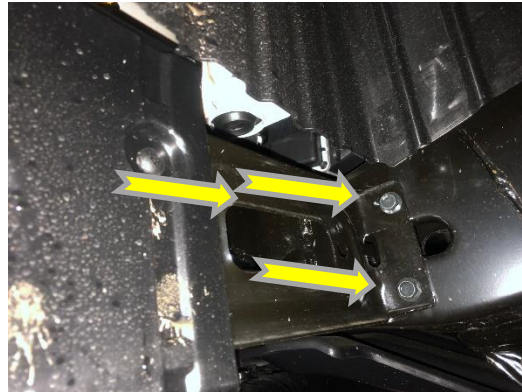

4. Remove the plastic covers around the tow hooks by pulling away from the front of the vehicle. Disconnect the sensor (if applicable). NOTE: When removing the covers be mindful of the sensor wiring harness so that you don't break the harness.



5. Using a 14mm socket, remove the 3 OE bumper mounting bolts. Set these bolts aside, they will be used again. (Both Sides)



6. With the help of a friend, remove the OE Bumper by pulling it outwards away from the truck and set it aside.

7. Using a 17mm socket, remove the bolts attaching the tow hooks to the truck frame. Set the shorter bolt aside, it will be used again.

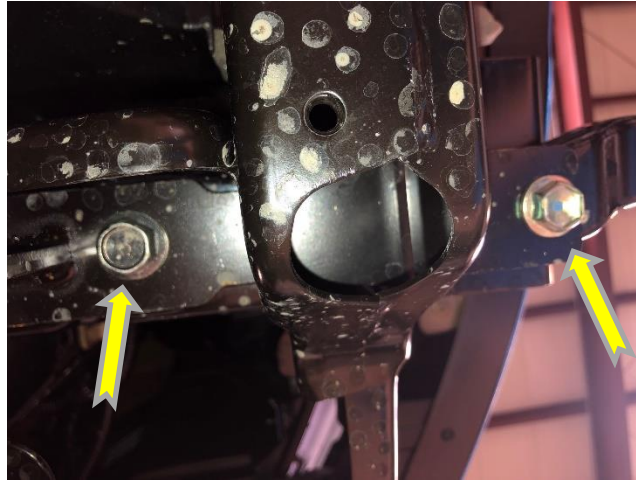

8. Remove the sensors, grommets, and sensor wiring harness from the OE bumper. **Be sure to note the position of the grommets, so that they can be installed in the correct locations on your new Hammerhead bumper.**

V. INSTALLATION OF HAMMERHEAD BUMPER

1. Lay bumper face down on a carpeted surface or piece of cardboard. Install winch and all lights in bumper using brackets and hardware provided by light manufacturer.
2. Install the OE sensor grommets, sensors, and sensor wiring harness into the bumper.
3. Layout Frame Mounts and OE hardware as shown.



- Using a 14 mm socket or wrench, a 17 mm socket or wrench, and hardware from hardware kit #188, attach the frame mounts to the frame of the truck. Use 4 washers on each of the bottom mounted OE bolts. Do not fully tighten.

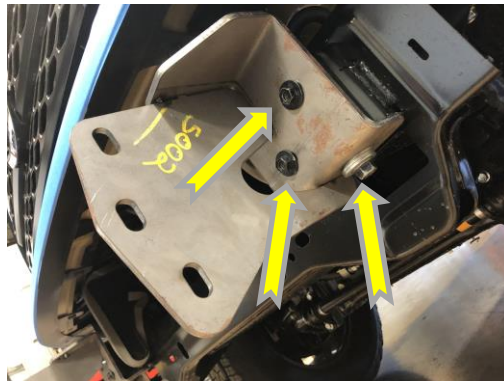

- Using a hoist or a few friends, attach bumper to frame mounts using hardware kit #58. Start all bolts before aligning bumper. Leave a minimum of 3/8" space between bumper and truck body. When the truck flexes off-road, this distance allows your bumper and truck body to have clearance. Tighten bolts with 3/4" wrench or socket. Tighten frame mounts at this time. Torque to specs on page one.



**Congratulations! Your Installation is now complete.
Thank You for your purchase!**