

2017-20XX, FORD RAPTOR

REAR BUMPER INSTALLATION INSTRUCTIONS



SAFETY

Know safety, no injury. Know injury, no safety. ~Author Unknown

If there are any questions, call 1-855-HHTOUGH

- **READ ALL SAFETY INSTRUCTIONS BEFORE INSTALLATION**
 - FOLLOW ALL INSTRUCTIONS FOR PROPER ASSEMBLY
 - WEAR APPROPRIATE EYE PROTECTION
 - EXERCISE CARE WHEN LIFTING COMPONENTS
 - USE APPROPRIATE TORQUE FOR BOLTS

SUGGESTED TORQUE VALUES FOR STEEL GRADE SAE 5 BOLTS

BOLT DIAMETER (INCH)	TREADS PER INCH	TORQUE (POUND-FEET)
1/4	20	7
5/16	18	14
3/8	16	25
7/16	14	40
1/2	13	60
9/16	12	88
5/8	11	120
3/4	10	200
7/8	9	302
1	8	466

I. PARTS LIST

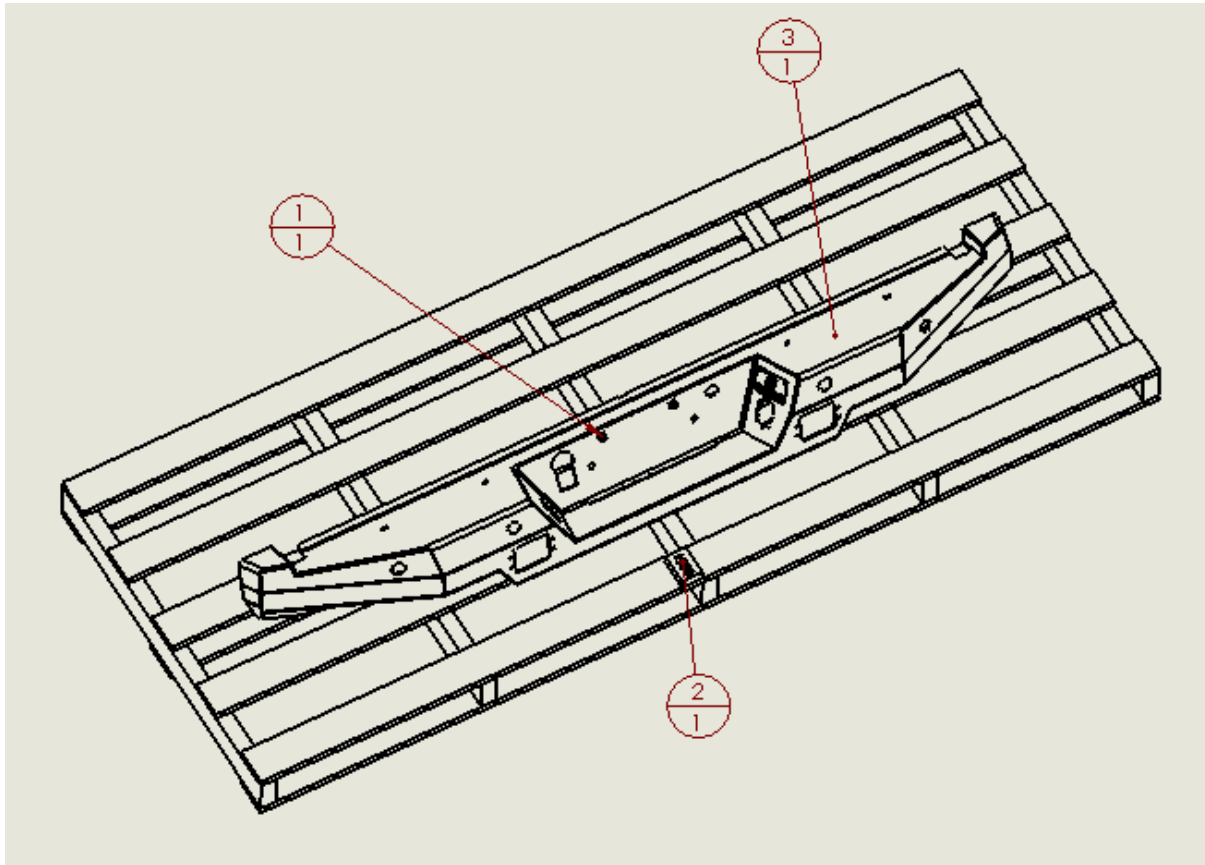

ITEM NO.	QTY	PART NUMBER	DESCRIPTION	
1	1	443-01-0086	LICENSE PLATE MOUNTING KIT	-
2	1	60K-56-0201	HARDWARE KIT #201	-
3	1	60P-56-0954	600-56-0954 POLISHED	-

II. TOOL LIST

1. Basic tool set
2. Blue masking tape
3. 10mm socket
4. 15mm socket
5. deep well 21mm socket
6. trim tool
7. T40 Torx bit
8. Pliers
9. 5/8" socket or wrench

III. REMOVAL OF BUMPER

1. Disconnect battery.
2. Using blue masking tape, mask along the profile of your truck above the bumper. This will help protect your truck from accidental scratches.
3. Unplug towing connector and sensor harness.
4. Using 10mm socket, remove bolt attaching wiring harness ground to frame. Using trim tool, remove two plastic Christmas trees attaching wiring harness to frame. NOTE: One is on top of the frame.



5. Using 10mm socket, remove two nuts attaching exhaust to bumper. (both sides)



6. Using a 15mm socket, remove bolt attaching ground strap to receiver hitch.



7. Set a piece of cardboard, foam, or carpet on a table to place bumper on when removed.

- Using a deep well 21mm socket, remove three nuts attaching bumper and receiver hitch to frame. (both sides) NOTE: Have someone hold bumper while doing this. (both sides) Remove bumper and set down on table.



- Remove towing connector by squeezing in on side tabs.
- Use key to remove spare tire access lock. NOTE: Key is located in back of key fob.
- Remove license plate lights from housings by gently twisting them.
- Using trim tool, disengage plastic tabs on outer shell of bumper. Start at the outside of the bumper and work towards the center. Pull up while prying with trim tool. (both sides)



- Rotate bumper with the mounting flanges down. Unplug center sensors.
- Using trim tool, remove plastic retainers attaching sensor wiring harness to bumper's plastic center.
- Remove plastic from metal portion of bumper center and set aside.
- Rotate bumper with receiver down. Unplug outer sensors.
- Using trim tool, remove six Christmas trees attaching outer portions of wiring harness to bumper.
- Using T40 torx bit, remove five bolts attaching outer metal portions of bumper to receiver hitch. Set metal outer portion aside. (both sides)

IV. INSTALLATION OF HAMMERHEAD BUMPER

1. Reinstall OE hitch using OE hardware.
Note: Center hitch in frame slots vertically and tighten hardware.
2. Using 10mm socket and OE bolt, reattach ground wire removed from frame.
3. Using 15mm socket and OE bolt, reattach ground wire removed from hitch.
4. Install all OE sensors, harness, license plate lights, and spare tire lock on HH bumper.
5. Layout hardware from kit # 201 as shown.



6. Get a few friends to help you install bumper on OE mounts. Start all bolts before aligning bumper. Align bumper a minimum 3/8" below tailgate when open. Tighten bolts with 5/8" socket or wrench. Check OE bumper mounts for tightness at this time.
NOTE: Depending on your truck, you may need to use OE Torx bolts for the bottom bolt on each side.



Congratulations! Your product installation is now complete.
Thank you for your purchase.