

2007-2010 CHEVY 2500-3500

FORMED BRUSHGUARD – X SERIES

FRONT BUMPER INSTALLATION INSTRUCTIONS



SAFETY

Know safety, no injury. Know injury, no safety. ~Author Unknown

If there are any questions, call 1-855-HHTOUGH

- **READ ALL SAFETY INSTRUCTIONS BEFORE INSTALLATION**
 - FOLLOW ALL INSTRUCTIONS FOR PROPER ASSEMBLY
 - WEAR APPROPRIATE EYE PROTECTION
 - EXERCISE CARE WHEN LIFTING COMPONENTS
 - USE APPROPRIATE TORQUE FOR BOLTS

SUGGESTED TORQUE VALUES FOR STEEL GRADE SAE 5 BOLTS

BOLT DIAMETER (INCH)	TREADS PER INCH	TORQUE (POUND-FEET)
1/4	20	7
5/16	18	14
3/8	16	25
7/16	14	40
1/2	13	60
9/16	12	88
5/8	11	120
3/4	10	200
7/8	9	302
1	8	466

I. PARTS LIST

ITEM NO.	QTY.	PART NUMBER	DESCRIPTION	
1	1	601-56-1438	PASS FRAME MOUNT WELDMENT	-
2	1	601-56-1439	DRIVER FRAME MOUNT WELDMENT	-
3	1	60A-56-1001	600-56-1001 ASSEMBLED	-
4	1	60K-56-0001	HARDWARE KIT #1	-

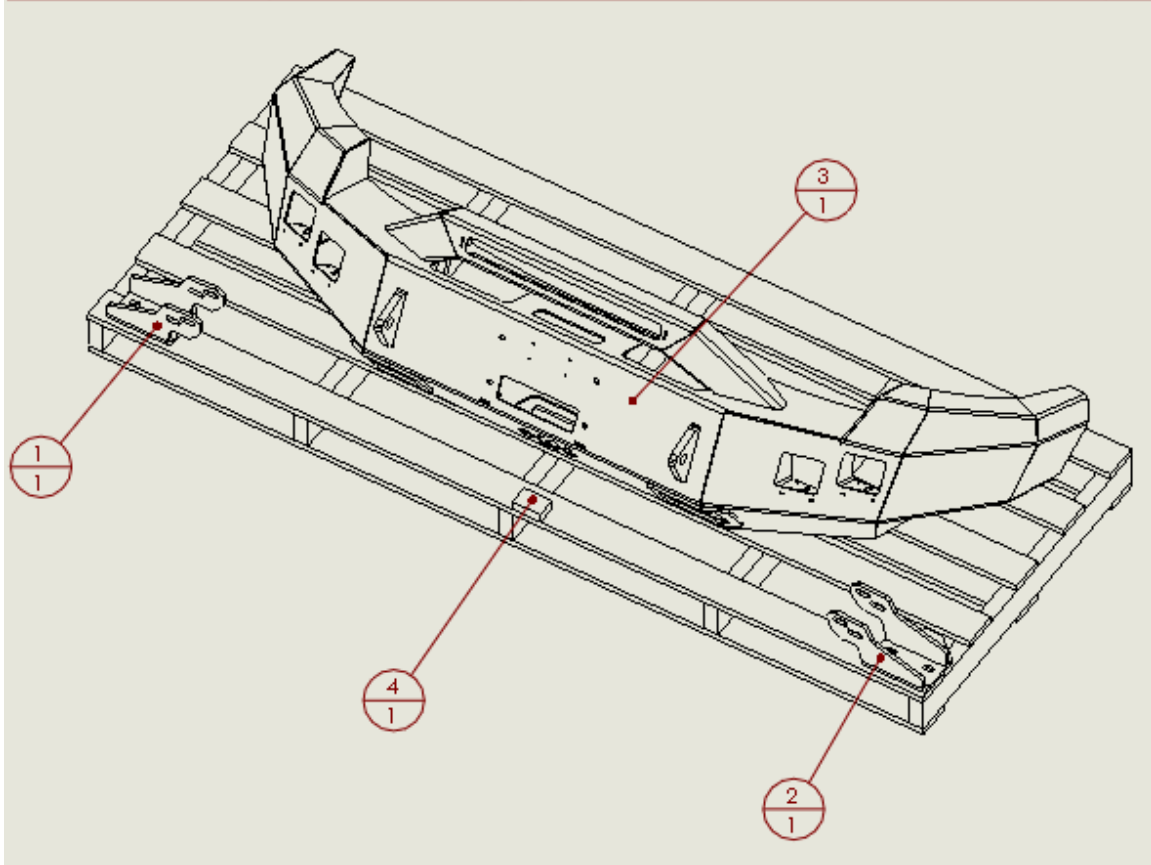

II. TOOL LIST

1. Basic tool set
2. ¾" wrench
3. ¾" socket
4. 10mm socket
5. 15mm socket
6. Flathead screw driver
7. Pliers
8. 21mm socket

III. REMOVAL OF OEM BUMPER

1. Remove all components from box and compare to parts list above.
2. Unplug OEM fog lights. (if applicable)
3. Using 10mm socket, remove two bolts attaching lower fenderwell to bumper. (both sides)



- Using 15mm socket, remove three bolts attaching side bumper brace to frame. Set brace aside. (both sides)

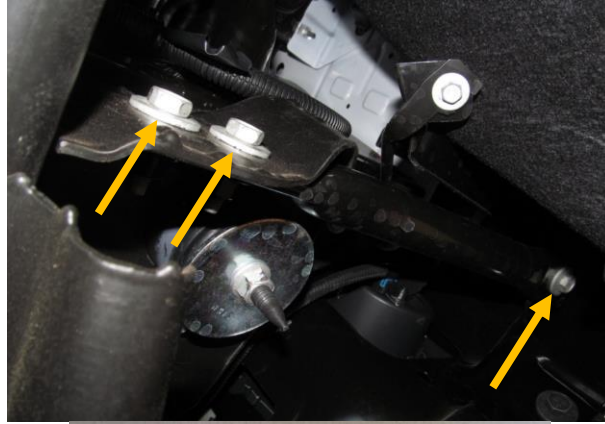

- Open hood and remove ten clips from shroud. Set shroud aside. It will be reused. NOTE: A flathead screw driver can be used to gently pry up the inside of the clip. Then pry up the body of the clip.

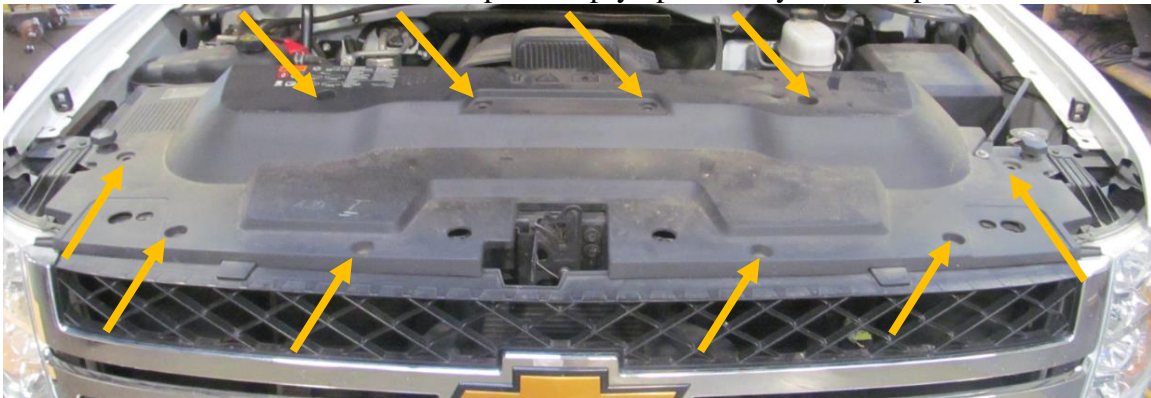

6. Using 10mm socket, remove four screws attaching top of grill to truck. Screws will be reused.

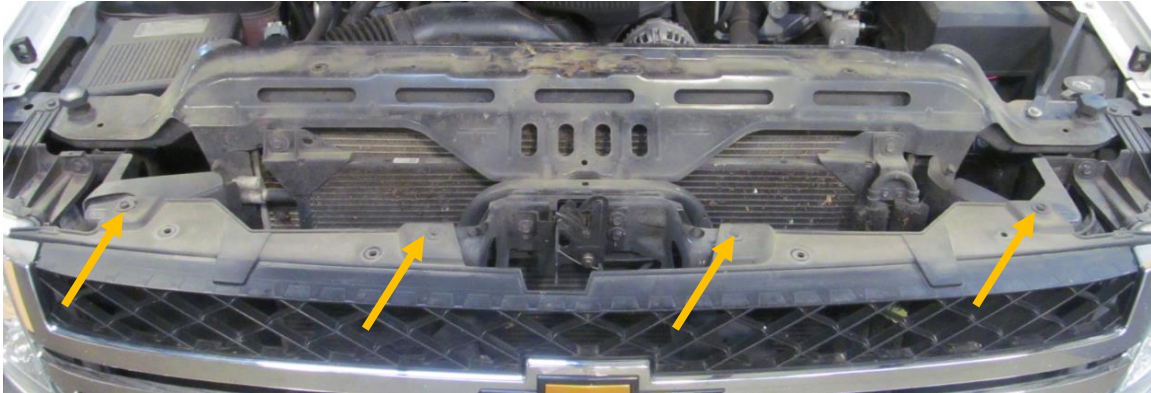

7. There are six metal clips on the back of the grill that need to be removed. You can access them from the top of the grill. Start on the right side of the truck and work towards the left. Use a set of pliers to gently squeeze on the back of the metal clips while gently pushing in on the grill. After the clip is disengaged, gently pull out. Set grill aside. It will be reused.
8. Using 21mm socket, remove two bolts attaching OEM bumper OEM mounts. Remove bumper and set aside.



9. Using 21mm socket, remove two nuts on OEM bolt strip attaching OEM frame mounts to frame. Remove bolt strip and mounts. Bolt strip will be reused. (both sides)

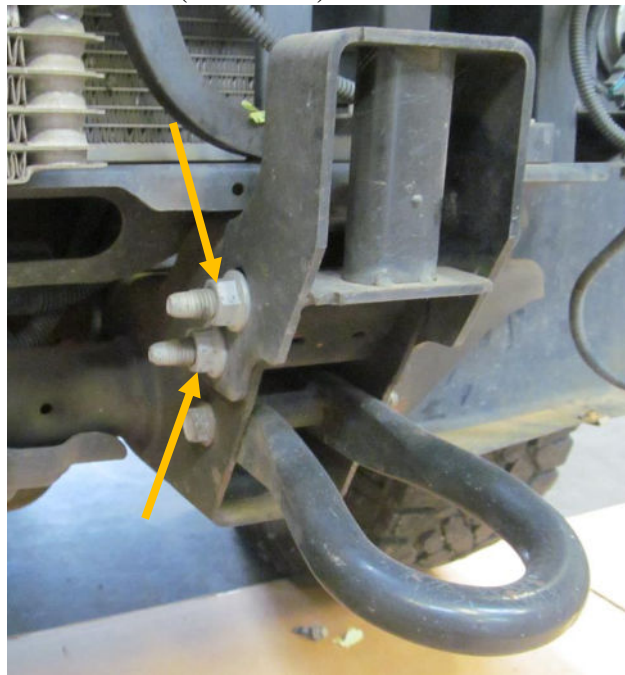

10. Using 18mm socket and wrench, remove two bolts attaching OEM tow hook to frame. Set tow hook aside. (both sides)

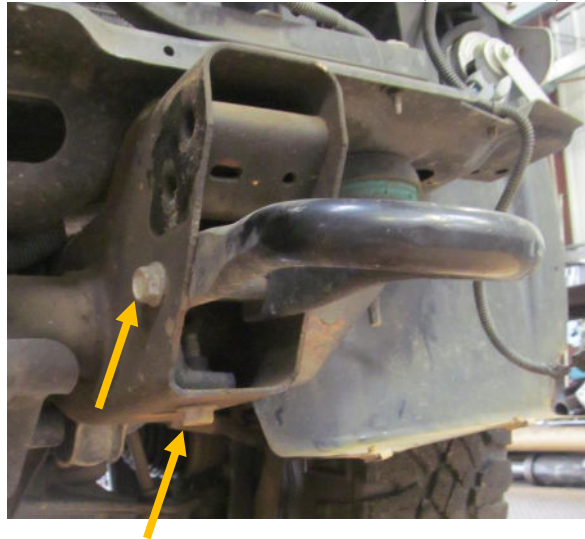

11. Reinstall grill and shroud with OEM hardware.



IV. INSTALLATION OF HAMMERHEAD BUMPER

1. Install all lights and winch in Hammerhead bumper at this time.
2. Layout Hammerhead frame mounts and OEM bolt strips as shown.



3. Attach Hammerhead frame mounts to OEM frame with OEM bolt strips. Push mounts to top of slots and tighten.
NOTE: Insert bolt strips from the outside.



4. In this step you will use hardware from kit # 1. Install and align Hammerhead bumper using six ½” -13 x 2” bolts, 12 ½” flat washers, six ½” lock washers and six ½”-13 nuts. Use this hardware to attach bumper to HH frame mounts.

NOTE: Align bumper a minimum of ¼” below headlights. When truck flexes off-road, this distance allows your bumper and body to have clearance. Use ¾” wrench and socket to tighten all bumper hardware.

5. Trim plastic fender wells to match bumper. (both sides)



Congratulations! Your bumper installation is now complete.
Thank you for your purchase.