

## CONTACT

### EMAIL:

info@ranchhand.com

### PHONE:

1.800.366.9712

### ADDRESS:

959 State Hwy 95 N  
Shiner, TX 77984



**RANCH HAND**  
PROTECT YOUR TRUCK

## MAINTENANCE/CARE

- Periodically check and tighten all fasteners.
- Stripped, fractured, or bent bolts or nuts need to be replaced.
- After washing of the vehicle make sure to fully dry all surfaces

## SENSOR DISCLAIMER

PLEASE NOTE PARKING SENSORS ARE EXTREMELY DELICATE AND MUST BE HANDLED WITH CARE!

Do NOT touch or shift the clear rubber grommet that surrounds the sensor face. DO NOT glue housing into place until orientation and functionality is determined.

## APPENDIX

### Troubleshooting Vehicle Sensors

- Start with a general inspection of the sensor fitment. Check that both the sensors and the sensor clips are fully secure and the sensors are properly centered in the housing.
- Confirm plastic housing is in the correct mounting holes. Misplaced sensor housings could compress sensor and give false readings or faults.
- Use a clean microfiber to wipe the front face of the sensor.
- Inspect connection. Be sure that the sensor is firmly seated into the harness.
- Run through several start cycles (i.e. fully turn the vehicle on and off).
- Finally, disconnect the battery to reset the sensors.

## WARNING

*If your vehicle has adaptive cruise, please ensure that your adaptive cruise is working correctly once the Ranch Hand bumper is installed. Adaptive cruise may need to be cleaned or adjusted to ensure it functions properly. See your owner's manual for care of the adaptive cruise.*

Special care should be exercised in the handling, storage and installation of Kaspar Ranch Hand equipment. The actual weight of each piece of equipment will vary depending on style and model. The weight of the equipment is sufficient in volume to warrant special care, assistance and in some instances, the use of mechanical equipment during the transfer and installation of the equipment. Do not assume a position directly under the equipment during installation. Be sure the equipment has been connected and stabilized during installation to prevent falling or shifting of positions. Periodically check tightness of bolts to make sure they are tight, and unlikely to fail.

## SAFETY

- In order to help you make informed decisions about safety, we have provided installation instructions and other information.
- These instructions alert you to potential injury hazards
- Please do a job safety analysis before each task to identify potential hazards for your situation and remove/protect against them.
- You must use your own good judgment.
- Read and understand all safety precautions and instructions before installing this product

## HAZARD

**FAILURE TO OBSERVE THESE INSTRUCTIONS COULD LEAD TO SEVERE INJURY OR DEATH.**

- Always remove jewelry and wear eye protection.
- Always use extreme caution when jacking up a vehicle for work. Set emergency brake and use tire blocks. Locate and use the vehicle manufacturers designated lifting points. Use jack stands.
- Always use appropriate and adequate care in lifting components into place.
- Always insure components will remain secure during installation and operation.
- Always wear safety glasses when installing this kit. A drilling operation will cause flying metal chips. Flying chips can cause serious eye injury.
- Always use extreme caution when drilling on a vehicle. Thoroughly inspect the area to be drilled (on both sides of material) prior to drilling, and relocate any objects that may be damaged.
- Always use extreme caution when cutting and trimming during fitting.
- Always tighten all nuts and bolts securely per installation instructions.
- Always route electrical cables carefully. Avoid moving parts, components that become hot and rough or sharp edges.
- Always insulate and protect all exposed wiring and electrical terminals.
- Always perform regular inspections and maintenance on mounts and related hardware.



**RANCH HAND**  
PROTECT YOUR TRUCK

# INSTALLATION INSTRUCTIONS

### DESCRIPTION

2015-Up Chevy  
2500HD/3500HD Legend Front  
Bumper Bumper

### PART #:

FBC15IBLR/BTC15IBLR/  
FSC15IBL1/BSC15IBL1

## INSTALLATION INSTRUCTIONS:

1. Open the hood and remove the plastic radiator cover. There will be (12) plastic clips.
2. Remove the (4) 10mm bolts holding the grille in place. Carefully pry grille away from its position there will be (10) snap clips.
3. Remove the factory side brackets. There will be (3) 15mm bolts on each side.
4. Remove the factory bumper by removing the two 18mm bolts from each side of the frame. They will be facing down.
5. Lay the bumper down then remove the sensor and fog light wires (if present) from the bumper. You will have to remove the (2) large black bumper support plates to remove sensors.
6. Reinstall the factory grille and plastic radiator cover.
7. Remove the two black bumper mounting plate by removing the (4) 15mm bolts. The bolts will be used to install the Ranch Hand Frontend.
8. Remove the side and bottom tow hook bolt. Mount the support brackets to the outer side of the frame rails. Reinstall the factory bolts.
9. Install splash guard by removing (1) 10mm bolt. Place a 5/16" flat washer between the truck body and the splash guard. Reinstall factory bolt and use 5/16" bolt in the other hole.
10. For the Legend frontends remove the outer sensor brackets from factory bumper. Install them into the bottom of the frontend.
11. If fog lights are present, mount them to the fog light brackets provided and then to the frontend. Follow instructions in LBC151BP to install.
12. Mount the frontend to the frame by reusing the 15mm factory bolts. Level the frontend and then tighten bolts. Use 1/2" bolts to mount the frontend to the support brackets.
13. Mount the license plate using 1/4" bolts to the bottom grille insert.
14. Hook up the sensor and fog light wires. You can run them through the square opening in the mounting brackets just below the top plate. Adjust the lights and sensors if needed.
15. Make sure all nuts and bolts are tight!!

## 2015-Up Chevy 2500HD/3500HD Legend

### Front Bumper

**FBC151BLR/BTC151BLR/FSC151BL1/  
BSC151BL1**

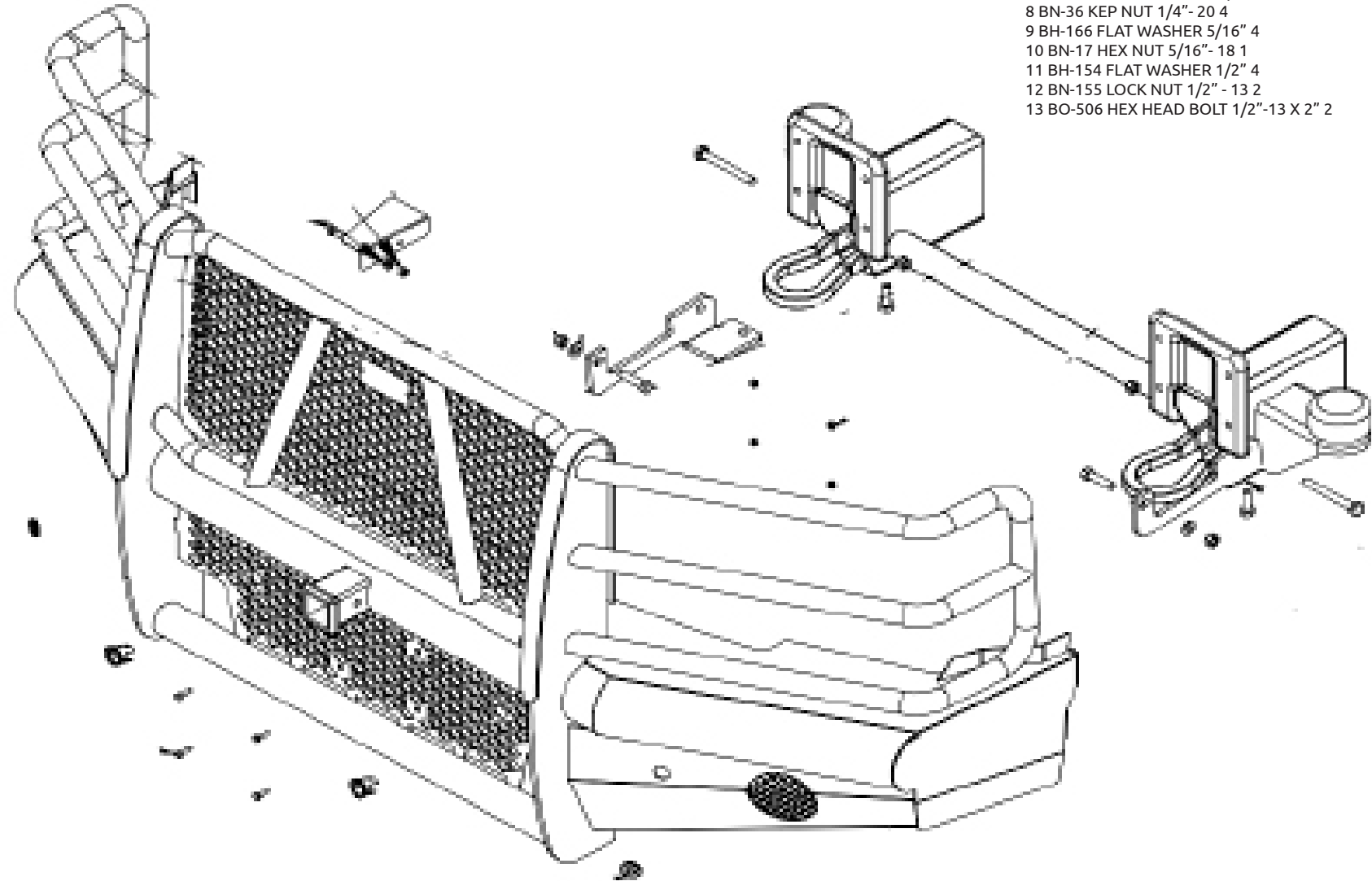

## TOOLS REQUIRED

Metric & SAE Sockets  
Metric & SAE Wrenches

## PARTS LIST

ITEM NO.	PART NUMBER	DESCRIPTION	QTY.
1	FBC151SBDBL	MOUNTING BRACKET DRIVER	1
2	FBC151SBPBL	MOUNTING BRACKET PASSENGER	1
3	FBC151SGBL	SPLASH GUARD	1
4	RGROMMET 1" X .8125	RUBBER GROMMET	4
5	BP-428	BUTTON PLUG	4
6	BO-136	HEX HEAD BOLT 5/16"-18 X 1"	1
7	BO-459	HEX HEAD BOLT 1/4"-20 X 1"	4
8	BN-36	KEP NUT 1/4"-20	4
9	BH-166	FLAT WASHER 5/16"	4
10	BN-17	HEX NUT 5/16"-18	1
11	BH-154	FLAT WASHER 1/2"	4
12	BN-155	LOCK NUT 1/2"	13
13	BO-506	HEX HEAD BOLT 1/2"-13 X 2"	2