

PARTS LIST:

1	Rear LD1 Bumper Assembly	8	4mm x 10mm Button Head Bolts
4	Sensor Hole Plugs	1	4mm Wrench
2	Plastic Plugs for license plate mount	1	6mm Wrench
10	Nylon Wire Ties		

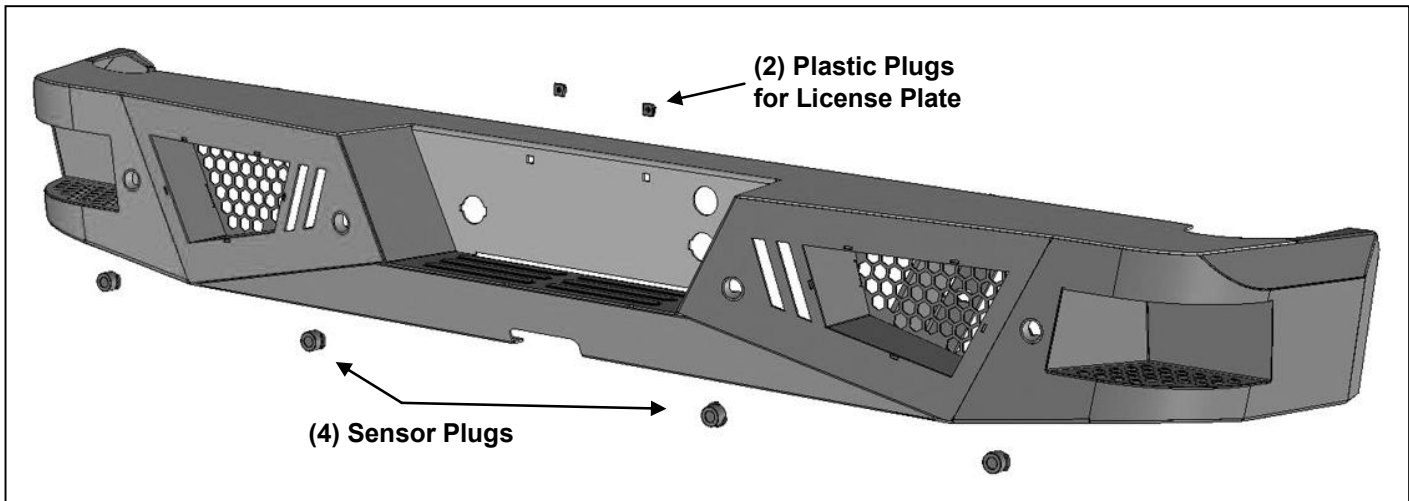

PROCEDURE:

REMOVE CONTENTS FROM BOX. VERIFY ALL PARTS ARE PRESENT. READ INSTRUCTIONS CAREFULLY BEFORE STARTING INSTALLATION. ASSISTANCE IS RECOMMENDED TO AVOID POSSIBLE INJURY OR DAMAGE TO THE VEHICLE.

BUMPER IS DESIGNED TO INSTALL ON MODELS WITH FACTORY TOW HITCH ONLY.

1. Release the clips attaching the license plate lights and remove the lights, **(Figure 1)**.
2. Remove the license plate from the bumper. Unplug the license plate lights, trailer plug and sensors, (if equipped). Release the wiring harness from the clips attached to the back of the bumper, **(Figure 2)**. Move all wiring harnesses away from bumper.
3. Place blocks or jack stands under the bumper to support it during mounting bolt removal. Once the bumper has been safely supported, remove the factory hex bolts attaching the outer bumper to the inner reinforcement or tow hitch, **(Figure 2)**. With assistance, move outer bumper to a clean surface. Next, remove the (6) hex nuts attaching the inner reinforcement or tow hitch to the end of the frame, **(Figure 3)**.
4. Remove the long bolt plates from the inner reinforcement or tow hitch. Insert the bolt plates into the LD1 Bumper, **(Figure 4)**. On models with factory tow hitch, slide the hitch into position against the Bumper and bolt plates, **(Figure 5)**. With assistance, position the Bumper Assembly, (and hitch), up to the mounting flanges on the end of the frame, **(Figure 6)**. **NOTE:** Bumper reinforcement, (models without receiver hitch only), cannot be reinstalled. Bumper is designed to install with factory tow hitch only.
5. Reuse the factory hex nuts to attach the Bumper to the ends of the frame, **(Figure 6)**. Do not tighten hardware.
6. Level and adjust the bumper and fully tighten all hardware.
7. Slowly lower tailgate and check for clearance. Adjust Bumper height as necessary.
8. Reinstall the license plate lights and trailer plug.
9. Use the included (2) push-in plugs to attach the license plate to the Bumper, **(Figure 7)**.

10. Models with bumper mounted sensors:

- a. Remove the rubber plugs from the sockets in the bumper assembly. Push the sensor in from the back of the bumper. Secure each sensor to the socket with (2) 4mm x 10mm Button Head Screws, **(Figure 8)**. **IMPORTANT:** Sensors fit snug in sockets. The 4mm Screws are used to apply slight pressure to lock the sensors in place. Tighten both screws evenly until they touch the sensor body only. Do not overtighten screws or damage to sensors will result.
- b. Reattach the factory wiring harness to sensors.

11. Attach the wiring harness to the lights and trailer plug.

12. Do periodic inspections to the installation to make sure that all hardware is secure and tight.

13. **LED light installation at ends of bumper** as supplied with bumper or sold separately.

- a. Insert light into opening and up to mounting slots. Check for clearance between front and back of light. If necessary, remove the screen from the back of the opening for additional clearance or access to light, **(Figure 9)**.
- b. Follow the light manufacturer's instructions to attach (1) light to the center slot or (2) lights to the inner and outer slots in the top of the light opening.
- c. Repeat the above steps for passenger side light installation.
- d. Follow light manufacturer's instructions to properly wire the light.

14. Use the included Wire Ties to secure the wiring harness to the bumper and frame as necessary.

15. Do periodic inspections to the installation to make sure that all hardware is secure and tight.

To protect your investment, wax this product after installing. Regular waxing is recommended to add a protective layer over the finish. Do not use any type of polish or wax that may contain abrasives that could damage the finish. Mild soap may be used to clean the Bumper assembly.



(Fig 1) Unplug license plate lights

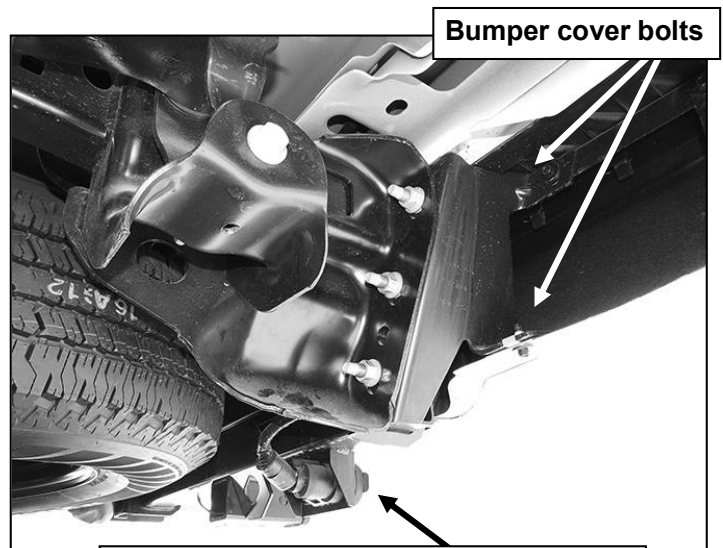

(Fig 2) Unplug and remove 7-wire trailer plug and bumper sensors if equipped

WARNING! Do not remove bumper bolts unless the bumper is properly supported on blocks or stands or the bumper may fall.

Once cover is removed, remove the (3) factory hex nuts attaching tow hitch assembly to frame

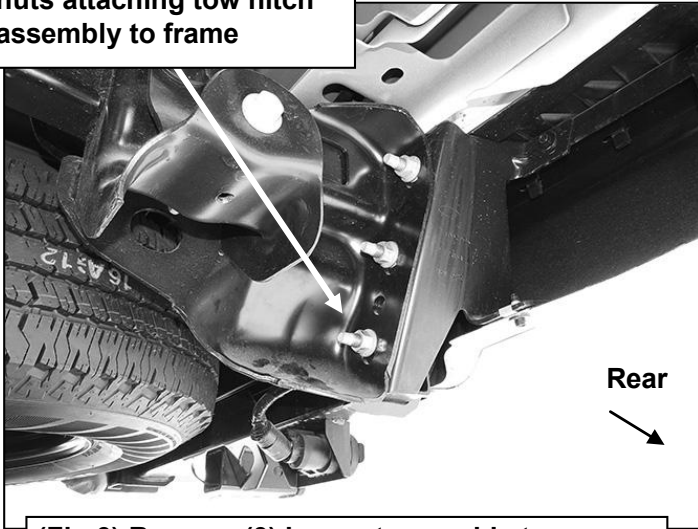

(Fig 3) Remove (3) hex nuts per side to remove bumper reinforcement or receiver hitch

WARNING! Do not crawl under bumper unless the bumper is properly supported on blocks or stands or the bumper may fall.



(Fig 4) On models without received hitch, reuse triple bolt plate to attach bumper to ends of frame

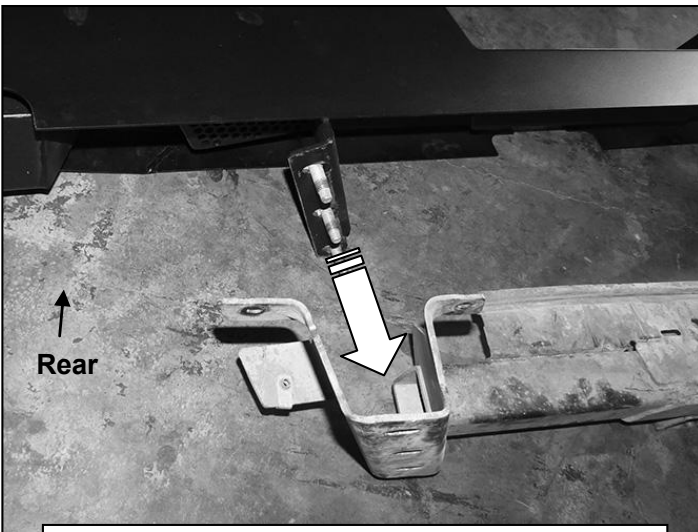

(Fig 5) On models with factory receiver hitch, slide Bumper up against the hitch. Insert triple bolt plates through bumper and hitch

Reuse factory hex nuts to attach Bumper and receiver hitch to frame

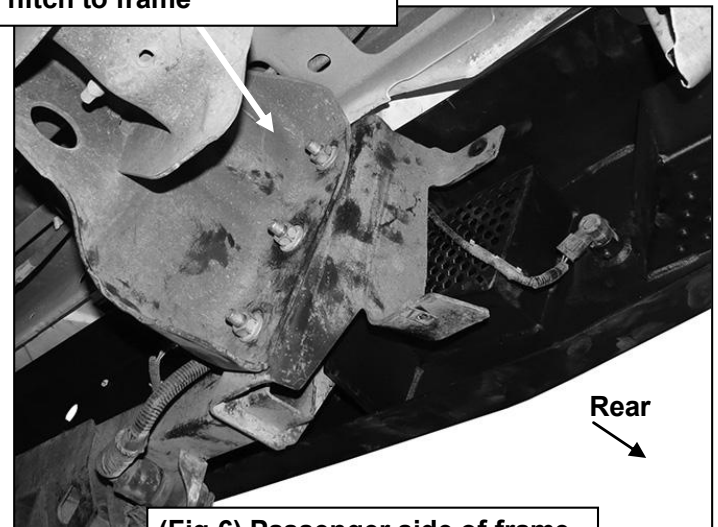

(Fig 6) Passenger side of frame

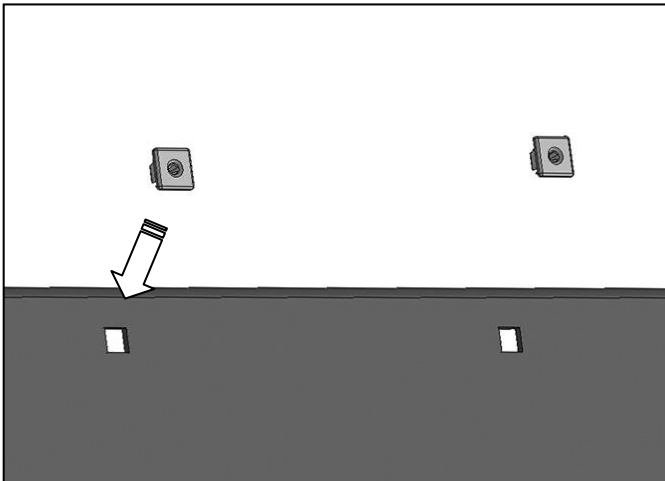

(Fig 7) Push plastic plugs into holes for license plate

Remove screens if necessary for additional clearance around or access to lights

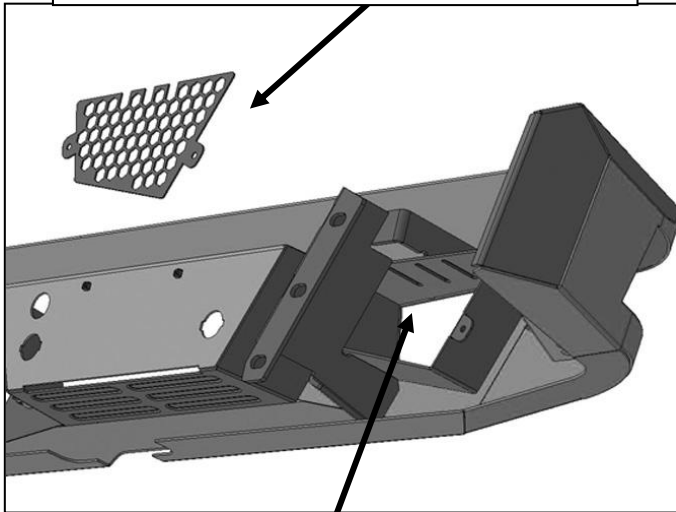

(Fig 9) Attach single light to center slot or use inner and outer slots for dual lights

(2) 4mm Screws

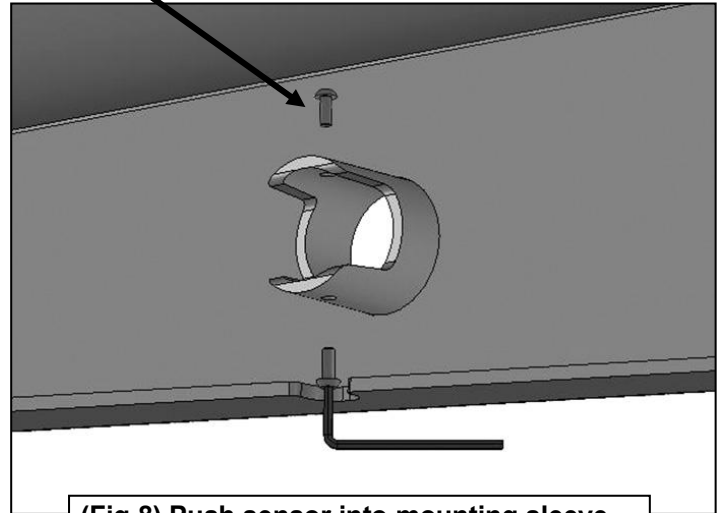

(Fig 8) Push sensor into mounting sleeve. Use 4mm Screws to lock sensor in place.

IMPORTANT: Sensors fit snug in sockets. The 4mm Screws are only used to apply slight pressure to lock the sensors in place. Tighten both screws evenly until they touch the sensor body only. Do not overtighten screws or damage to sensors will result.



Complete Installation

WARRANTY POLICY & PROCEDURE

Contact your Body Armor 4x4 Distributor or Body Armor 4x4 directly regarding any issue prior to removing product from vehicle. If it appears said product is warrantable, you will be given a Return Authorization Number (RA #) and asked to return said product freight pre- paid. The RA # must appear on the outside of the carton/box of any returned product. Unauthorized returns will be refused. RA # must be given by Body Armor 4x4 in advance of return.

BODY ARMOR LIMITED LIFETIME WARRANTY

Body Armor 4x4 (BA) warrants to the original purchaser that these products will be free from defects in material and workmanship prior to shipping and/or installation for the life of the product. This non-transferable limited lifetime warranty does not cover damage or impairment in any part due to misuse, improper installation, accident or contact with on-road or off-road hazards, product modification, improper or inadequate cleaning and/or maintenance. All other warranties and representations express or implied are hereby disclaimed, including fitness for merchantability and buyer's intended use or purpose.

BA products are built and sold for highway and off-road use. The original purchaser assumes all risks as to the selection, suitability and performance of all goods and products purchased.

BA's sole and exclusive obligation under this warranty shall be to repair or replace the item(s) and their discretion and BA will not issue any credit or refund to the consumer. Proof of purchase is required on all warranty claims. BA may require pictures to diagnose the warranty claim and may require the product(s) be returned if determined by BA to be necessary. If a return is required then a RGA number will be issued by BA. Any item arriving to BA without a valid

RGA number will be refused and sent back. Upon evaluating the RGA and no valid warranty claim is made, the RGA will be returned to the consumer at their expense or disposed by BA after 60 days. BA will not be responsible for incidental charges such as removal, installation, shipping costs or lost during transit. Any items that are ordered in error, refused or cancelled are not considered a valid warranty claim and cannot be returned to BA.

WARRANTY PROCESS

Contact an authorized BA dealer to initiate warranty process. Authorized dealers must contact BA to assist in evaluating the warranty claims. Valid warranties will have a RGA issued. Once issued the dealer will request the product be returned to BA facilities. Products purchased through an authorized BA dealer will be refunded and/or credited by that BA dealer.

Warranty contact: orders@bodyarmor4x4.com

Return address: Body Armor 4x4, 1050 N. Vineyard Ave. Ontario CA, 91764, P: 951-808-0750

FINISH WARRANTY

The finish is warranted to be free of defects for a period of 3 years from date of purchase. Product(s) that have been abused, altered, incorrectly installed or used in competition are void of said warranty. Surface rust, pitting or discoloration is a direct result of improper maintenance is not covered by this warranty. It is the responsibility of the owner to preserve and maintain the finish of their product(s). In areas where high concentrations of road salts and other corrosive agents are used, rust or damage to the finish may occur if BA product(s) are not properly maintained. Lack of proper maintenance in these areas may void the finish warranty. See below for routine maintenance tips and recommendations.

**PRODUCT CARE AND MAINTENANCE**

Textured coat finished should be cleaned ONLY with a mild soap on a damp sponge.

BA recommends wiping down the product with a light coat of lubricate (i.e. WD40) periodically to maintain its luster.

DO NOT apply polish or wax that requires buffing for removal as this may damage the finish.

DO NOT coat the product with any type of shine such as Tire Shine or glossy aerosol or gel. This can cause discoloration, staining or bubbling.