

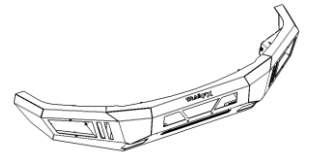

# Rear LD Bumper

Part No. FLDB005TI



Fits: **2016 Chevrolet Silverado 1500**



ASSISTANCE IS RECOMMENDED.



REMOVE CONTENTS FROM BOX. VERIFY ALL PARTS ARE PRESENT.



READ INSTRUCTIONS CAREFULLY BEFORE STARTING INSTALLATION.

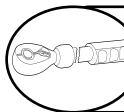

DO NOT OVER TORQUE. STANDARD OPERATING LOAD FOR TIGHTEN BODY MOUNT NUTS & BOLTS VARIES FROM **45 TO 65** FOOT POUND.



60-180 min



Cutting not Required



Drilling Not Required



support@trailfx.com



1 866 638 4870



POLISHED STAINLESS STEEL – LIMITED LIFETIME  
POWDER COATED BLACK – 3 YEARS

### PARTS LIST:

Qty	Part Description	Qty	Part Description
1	LD1 Front Bumper Assembly	6	10-1.5mm x 35mm Hex Bolts
1	Driver/left Frame Mounting Bracket	12	10mm x 27mm OD x 3mm Flat Washers
1	Passenger/right Frame Mounting Bracket	6	10mm Lock Washers
2	Tow Hook Extension Brackets	6	10mm Hex Nuts
4	Spacers (tow hooks)	2	8mm x 16mm Hex Bolts
1	License Plate Bracket	2	8mm x 25mm Hex Bolts
2	Plastic Plugs for License Plate	2	8mm Hex Nut
4	Sensor Plugs	4	8mm Lock Washer
1	Driver/left "L" Bracket (center LED light)	6	8mm x 24mm x 2mm Flat Washers
1	Passenger/right "L" Bracket (center LED light)	2	6mm x 20mm Button Head Bolts
2	12mm x 30mm Double Bolt Plates	4	6mm x 18mm x 1.6 Flat Washers
2	12mm x 35mm Single Bolt Plates	2	6mm Nylon Lock Nuts
6	12mm x 24mm OD x 2.5mm Flat Washers	1	6mm Wrench
6	12mm Lock Washers	8	4mm x 10mm Socket Head Screws
6	12mm Hex Nuts	1	4mm Wrench
		10	Nylon Wire Ties

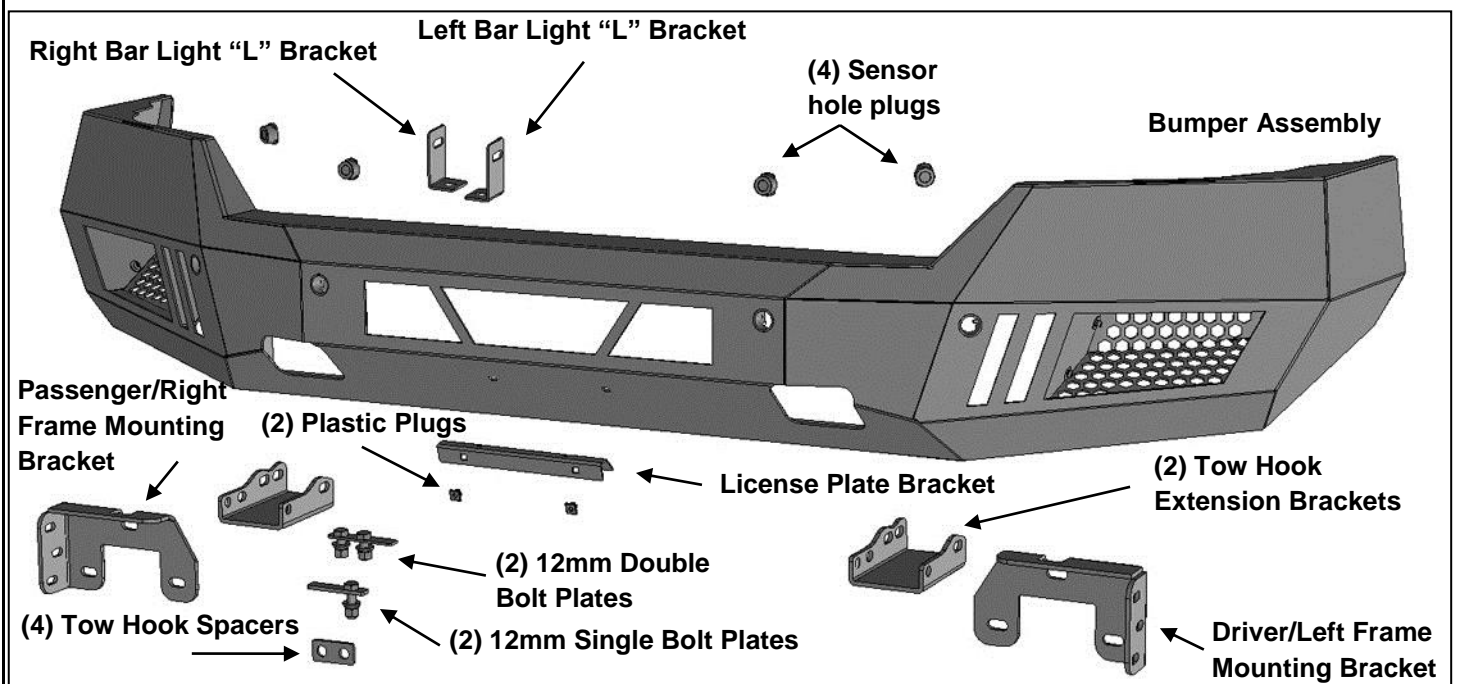

**INSTALLATION PROCEDURE:****TO AVOID POSSIBLE INJURY OR DAMAGE TO THE VEHICLE.**

1. Remove the license plate and bracket. On models with factory fog lights and/or bumper sensors, unplug the wiring harness leading to the bumper. Move harness away from bumper.
2. Next, open the hood and remove the plastic cover between the top of the radiator and the grille, **(Figure 1)**. Next, carefully remove the grille from the vehicle. **NOTE:** Grille is held in place with screws at the top and several clips, **(Figure 1)**. Remove the screws and firmly pull the grille straight out from the vehicle to release the grille from the clips, **(Figures 2 & 3)**.

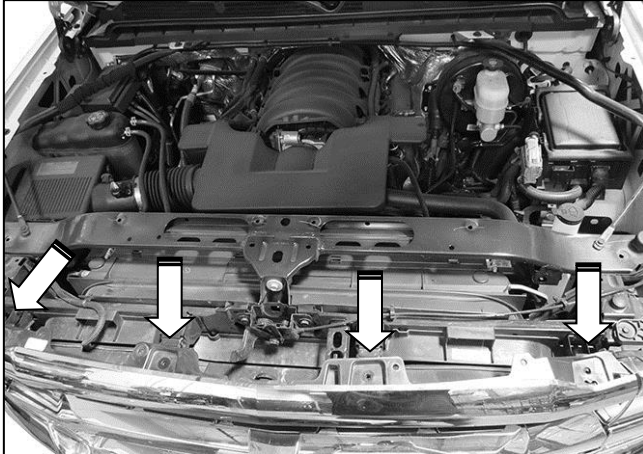

**(Fig 1) Remove cover between radiator and grille. Remove screws attaching top of grille (arrows)**



**(Fig 2) Firmly pull grille straight out from vehicle**

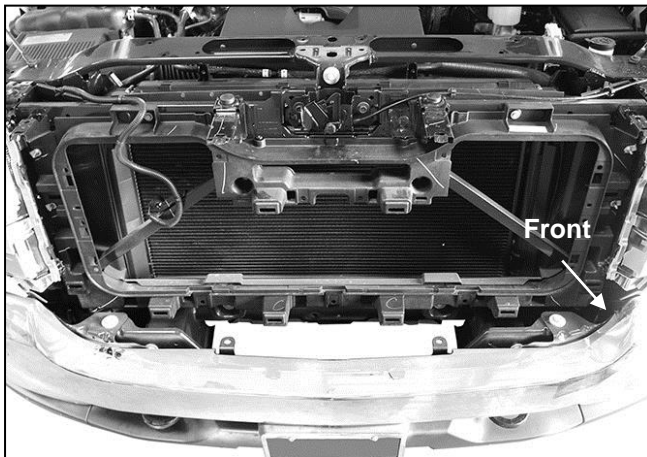

**(Fig 3) Grille removed to access top bumper bolts**

3. From behind the bumper, remove the outer bumper supports on each side of the frame, **(Figure 4)**.



**(Fig 4) Remove outer bumper support brackets**

4. Place blocks or jack stands under the front bumper to support it during mounting bolt removal. Once the bumper has been safely supported, remove the bumper bolts attaching the bumper assembly to the frame bracket bolted to the end of the frame, **(Figure 5)**. **WARNING!** Assistance is required to hold the bumper in place during bolt removal to prevent the bumper from falling. Carefully slide the bumper assembly off of the ends of the frame.

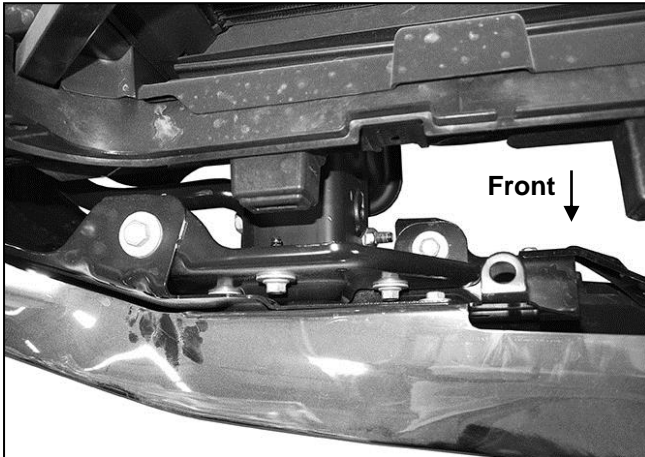

**(Fig 5) Remove bumper bolts attaching bumper to brackets- passenger side pictured from above**

**WARNING!** Do not crawl under bumper unless the bumper is properly supported on blocks or stands or the bumper may fall.

5. Once bumper has been removed, reinstall the plastic grille and cover removed in **Step 2**.
6. Remove both bumper brackets and tow hooks, (if equipped), from the ends of the frame, **(Figure 6)**.



**(Fig 6) Remove factory bumper brackets and tow hooks if equipped**

**Models without tow hooks, skip ahead to Step 10.**

**Models with tow hooks, follow, Steps 7—9**

7. Models with tow hooks, select (1) Single Bolt Plate and (1) Double Bolt Plate, **(Figure 7)**. Select (1) Tow Hook Extension Bracket, **(Figure 8)**. Slide the Bracket over the end of the frame. Line up the slots in the Bracket with the factory tow hook mounting holes. Insert the Bolt Plates into the open end of the passenger/right side of the frame and out through the holes in the side and Bracket. Secure the Bracket to the Bolt Plates with (3) 12mm Flat Washers, (3) 12mm Lock Washers and (3) 12mm Hex Nuts, **(Figures 8—10)**. Do not fully tighten at this time.

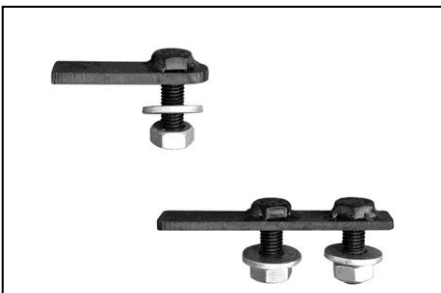

**(Fig 7) 12mm Single Bolt Plate and 12mm Double Bolt Plate**

Double Bolt Plate  
(2) 12mm Flat Washers  
(2) 12mm Lock Washers  
(2) 12mm Hex Nuts

Single Bolt Plate  
12mm Flat Washer  
12mm Lock Washer  
12mm Hex Nut

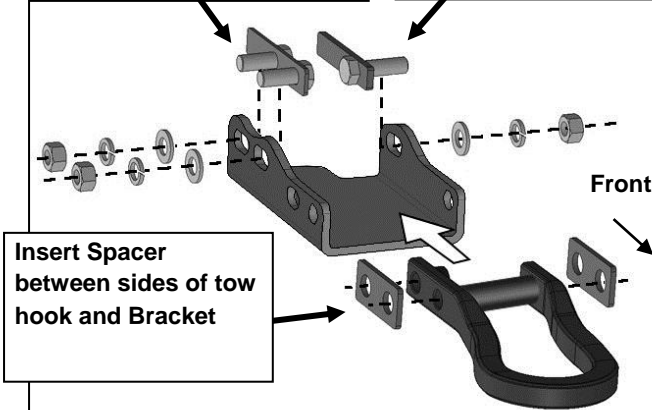

Insert Spacer  
between sides of tow  
hook and Bracket

(Fig 8) Attach Tow Hook Extension Bracket to bottom of frame. Slide a Spacer between each side of tow hook. Reuse factory hardware to attach tow hook to Bracket.

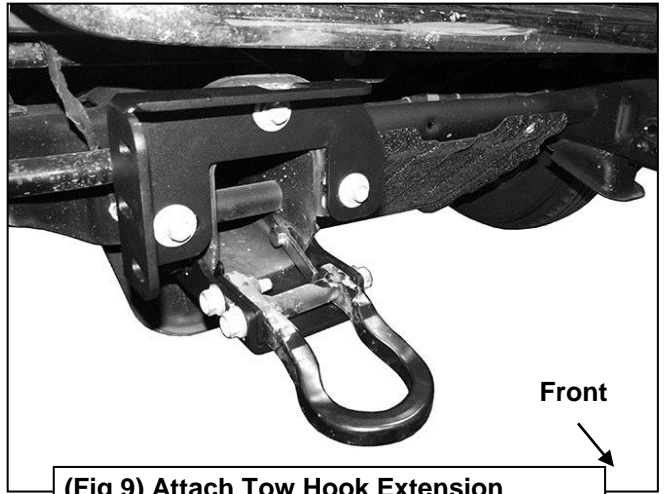

(Fig 9) Attach Tow Hook Extension Bracket to bottom of frame. Reuse factory hardware to attach Frame Bracket

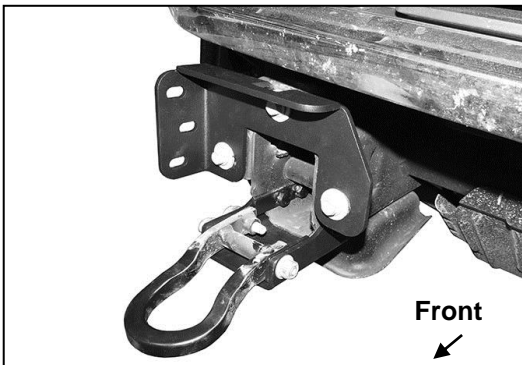

**WARNING!** Do not crawl under bumper unless the bumper is properly supported on blocks or stands or the bumper may fall.

(Fig 10) Reuse factory hardware to attach Frame Bracket

- 8. Select (1) tow hook. Place the tow hook on top of the Extension Bracket. Slide (1) Spacer Plate between each side of the tow hook and the Bracket. Reuse the factory hardware to attach the tow hook to the Extension Bracket, (Figures 8—10). Fully tighten tow hook and Extension Bracket hardware only. Do not tighten Frame Bracket hardware at this time.
- 9. Repeat Steps 7 & 8 to install the driver/left side Extension Bracket and tow hook.
- 10. Select the passenger/right Frame Bracket. Reuse the (3) factory bumper bolts to attach the Frame Bracket to the threaded bumper mount, (Figures 9 & 10). Do not fully tighten hardware at this time.

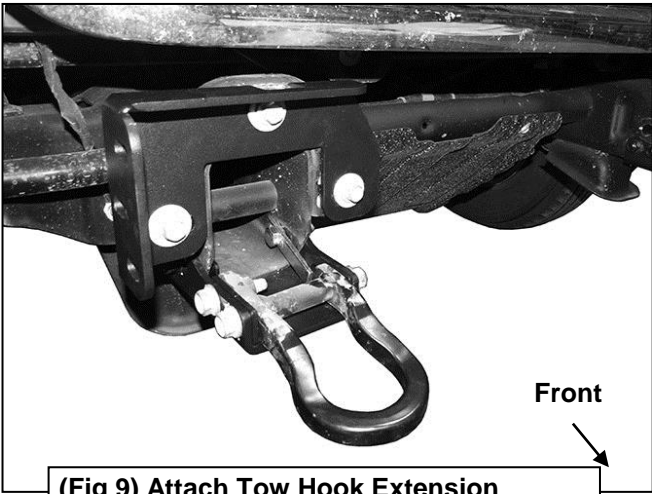

(Fig 9) Attach Tow Hook Extension Bracket to bottom of frame. Reuse factory hardware to attach Frame Bracket

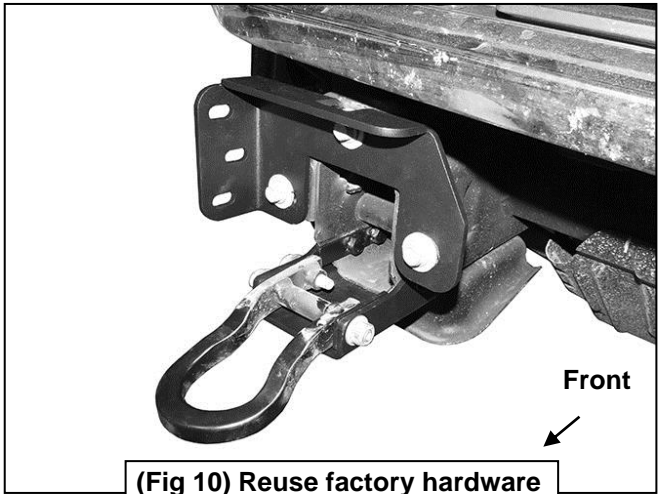

(Fig 10) Reuse factory hardware to attach Frame Bracket

11. Repeat **Step 10** to install the driver/left side Frame Bracket.
12. With assistance, position the Bumper Assembly up to and over the Frame Brackets. Temporarily support the weight of the Bumper. **WARNING:** To avoid possible injury or damage to the vehicle, do not proceed until the Bumper is fully and safely supported.
13. Line up the (3) holes in the passenger/right side mounting plate on the back of the Bumper with the (3) slots in the Frame Bracket. Attach the Bumper to the Bracket with the included (3) 10mm x 35mm Hex Bolts, (6) 10mm Flat Washers, (3) 10mm Lock Washers and (3) 10mm Hex Nuts, (**Figures 11 & 12**). Do not fully tighten hardware at this time. Repeat this **Step** to attach the driver/left side of the Bumper to the Frame Bracket.

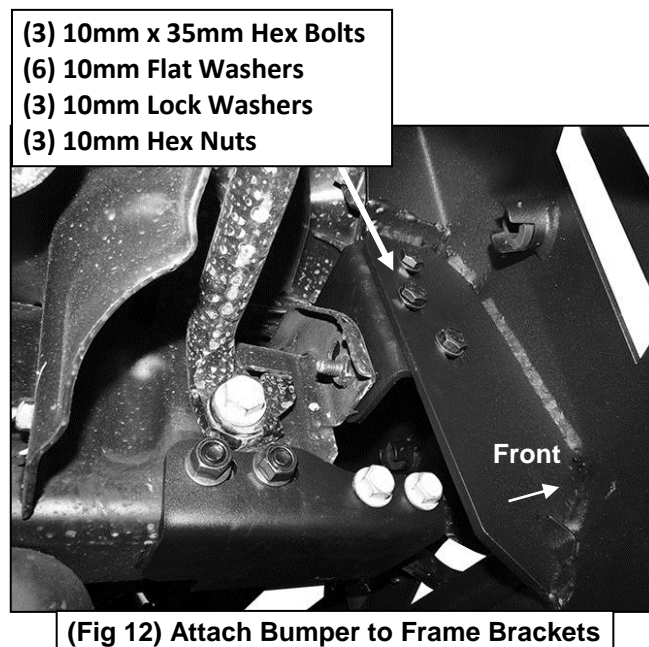
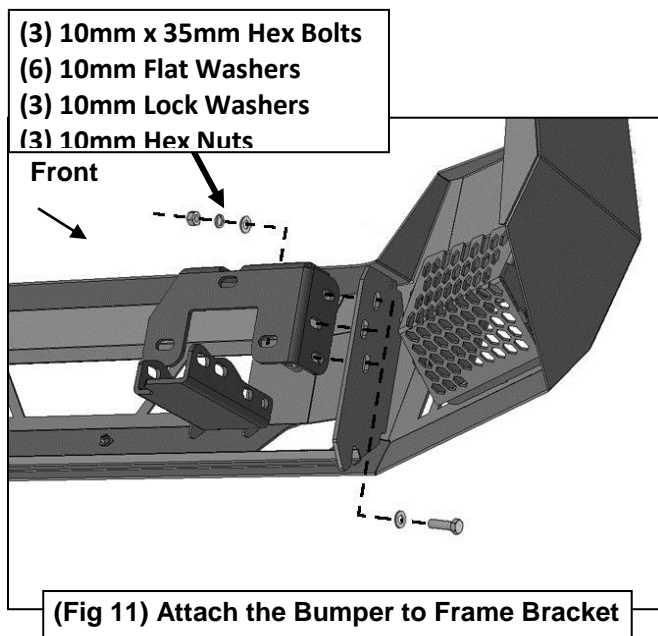

14. Level and adjust the bumper and fully tighten all hardware.

#### Models without bumper sensors:

- a. Select the included (4) Rubber Plugs.
- b. From behind bumper, push plugs into sensor mounting holes, (**Figure 13**).

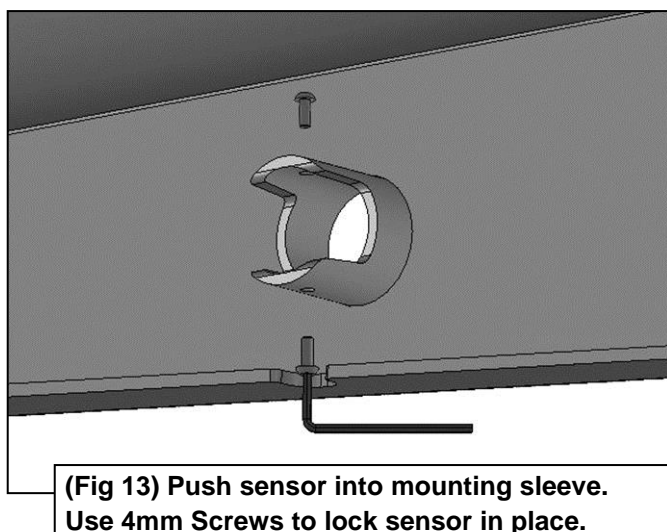

**IMPORTANT:** Sensors fit snug in sockets. The 4mm Screws are only used to apply slight pressure to lock the sensors in place. Tighten both screws evenly until they touch the sensor body only. Do not overtighten screws or damage to sensors will result.

**Models with bumper mounted sensors:**

- a. Push the sensor into the mounting socket in the back of the bumper.
- b. Secure each sensor to the socket with (2) 4mm x 10mm Button Head Screws, **(Figure 13)**. **IMPORTANT:** Sensors fit snug in sockets. The 4mm Screws are used to apply slight pressure to lock the sensors in place. Tighten both screws evenly until they touch the sensor body only. Do not overtighten screws or damage to sensors will result.

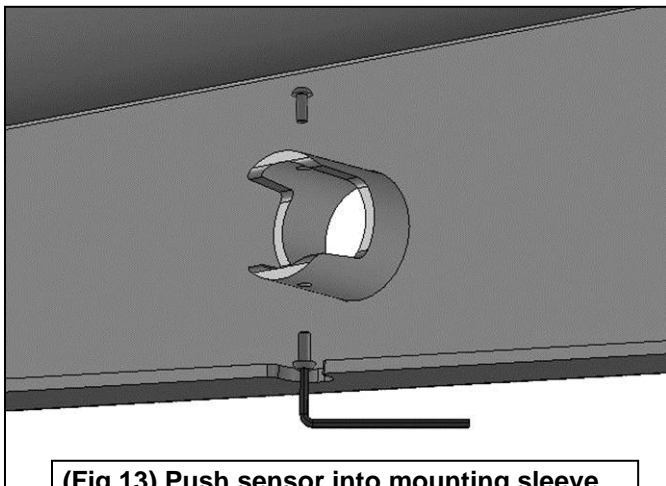

**(Fig 13) Push sensor into mounting sleeve.  
Use 4mm Screws to lock sensor in place.**

**IMPORTANT:** Sensors fit snug in sockets. The 4mm Screws are only used to apply slight pressure to lock the sensors in place. Tighten both screws evenly until they touch the sensor body only. Do not overtighten screws or damage to sensors will result.

15. If front license plate is required, attach the License Plate Bracket to the holes in the bumper with the included (2) 6mm x 20mm Button Head Screws, (4) 6mm Flat Washers and (2) 6mm Nylon Lock Nuts. Insert (2) Plastic Plugs into the square holes in the Bracket. Reuse the factory screws to attach the license plate to the plastic plugs, **(Figure 14)**.

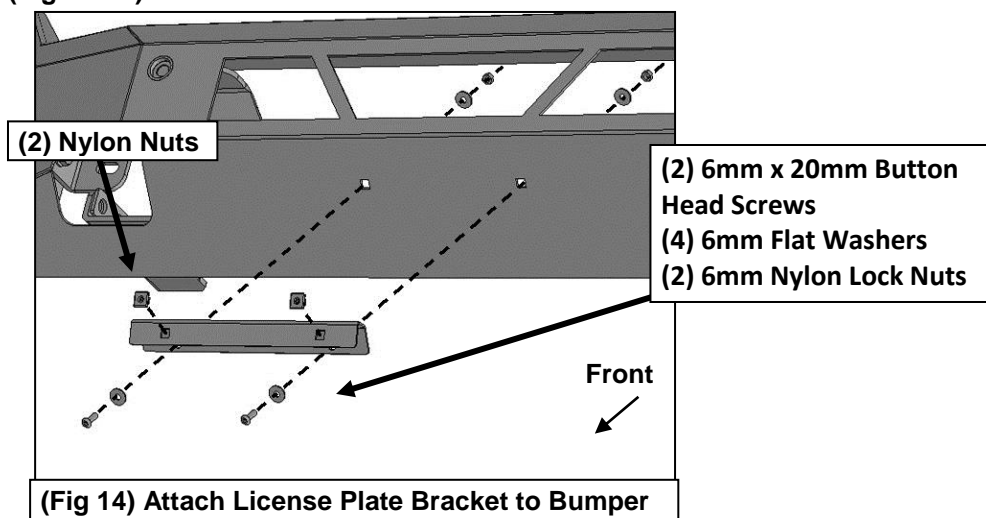

**(Fig 14) Attach License Plate Bracket to Bumper**



**16. Center LED light installation** (sold separately).

- a. Select the L/R "L" Brackets, **(Figure 15)**. Attach the Brackets to the top of the (2) mounting tabs welded onto the back of the bumper with the included 8mm x 25mm Hex Bolts, (4) 8mm Flat Washers, (2) 8mm Lock Washers and (2) 8mm Hex Nuts. Leave loose at this time.

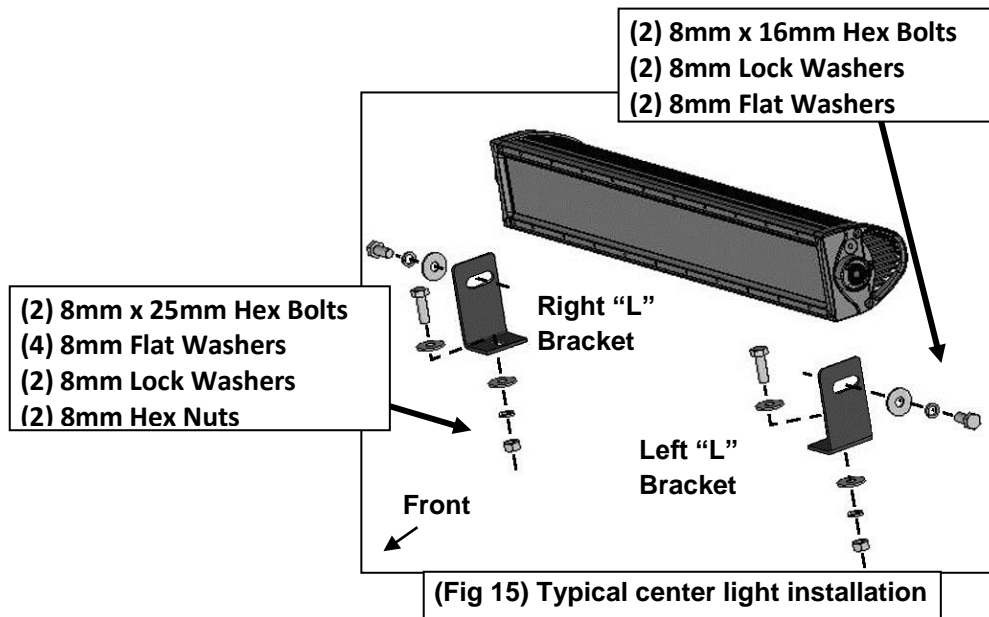

- b. Attach the LED light assembly to the "L" Brackets with the included (2) 8mm x 16mm Hex Bolts, (2) 8mm Lock Washers and (2) 8mm Flat Washers, **(Figure 15)**. Do not fully tighten hardware at this time. **IMPORTANT:** "L" Brackets are designed for 8mm light mounting hardware only. Modify "L" Brackets if necessary or use brackets supplied by your light manufacturer if possible to install hardware larger than 8mm.
- c. Follow light manufacturer's instructions to properly wire the light.

**17. LED light installation at ends of bumper** (sold separately).

- a. Insert light into opening and up to mounting slots in the top of the passenger/right light opening.
- b. Check for clearance between front and back of light. If necessary, remove the screen from the back of the opening, **(Figure 16)**.

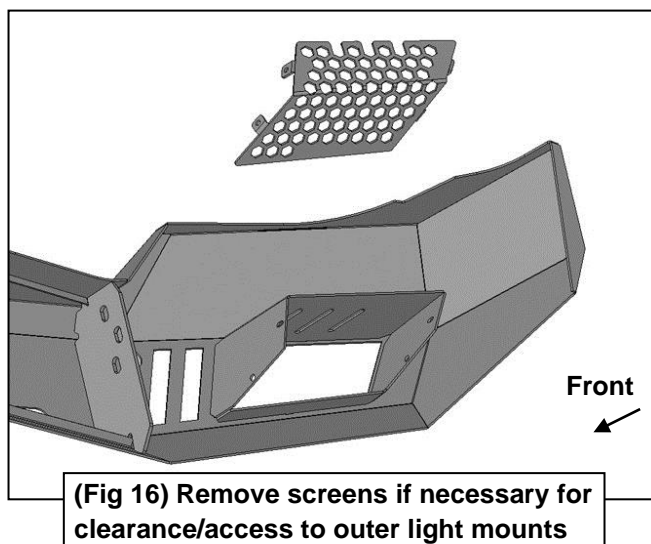

- c. Follow the light manufacturer's instructions to attach (1) light to the center slot or (2) lights to the inner and outer slots in the top of the light opening. **IMPORTANT:** On two light systems with (1) flood and (1) spot light per side, attach the flood light to the outer and the spot light to the inner slot.
  - d. Repeat the above steps for driver/left side light installation.
  - e. Follow light manufacturer's instructions to properly wire the light.
18. Do periodic inspections to the installation to make sure that all hardware is secure and tight.





**PRODUCT CARE**

- Periodically check the product to ensure all fasteners are tight and components are intact.
- Regular waxing is recommended to protect the finish of the product.
- **Use ONLY Non-Abrasive automotive wax.** Use of any soap, polish or wax that contains an abrasive is detrimental and can scratch the finish leading to corrosion.
- Aluminum polish may be used to polish small scratches and scuffs for **Stainless Steel finish.**
- Mild soap may be used to clean the product for both **Stainless Steel and Black finish.**

**FAQ's****1. Hardware's are not of correct size.**

*In GMC / Chevrolet truck model 2006 & up, customer needs to reuse the factory body bolts to install the bracket. If your vehicle is not GMC / Chevrolet 2006 & up, ensure that holes are not partially covered with any plastic grommet or rust? If it is, remove the plastic grommet & rust from the thread holes & re-try the installation.*

**2. Mounting Bracket are not getting Installed properly.**

*In some cases Illustration images shown in Installation manual may not be the exactly same as per actual vehicle images ,also if Driver / Passenger side mounting brackets are very identical in the design, suggest referring Parts Identification guide to avoid fitment issue.*

**3. Products are thumping / rattling after installation.**

*Ensure that all required mounting brackets / hardware's are installed & tighten correctly. Suggest using white lithium / regular grease between the metal to metal contact surfaces.*

**4. Side Bar is not aligning with vehicle / Step Pads are not aligning with vehicle doors.**

*Side bar may be interchanged or mounting brackets are not installed at the correct position in the vehicle. Refer Parts identification guide.*

**5. Missing / Excess Hardware.**

*Recheck hardware count as per the part list.*

**6. Product not installing properly.**

*Ensure make model year, cab length and bed size of your vehicle is listed in the application. All installation steps are followed correctly.*

Check out these other TrailFX Products!!

www.TrailFX.com



**SIDE BAR**

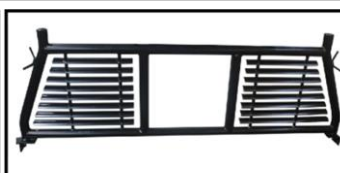

**HEADACHE RACKS**

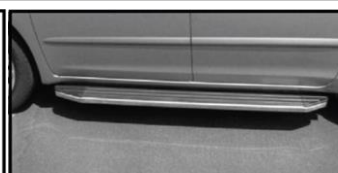

**RUNNING BOARDS**



**ROCKER GUARDS**

*Keystone Automotive Operations Inc. (KAO) warrants this product to be free of defects in material and workmanship at the time of purchase by the original retail consumer. KAO disclaims any other warranties, express or implied, including the warranty of fitness for a particular purpose or an intended use. If the product is found to be defective, KAO may replace or repair the product at our option, when the product is returned prepaid, with proof of purchase. Alteration to, improper installation, or misuse of this product voids the warranty. KAO's liability is limited to repair or replacement of products found to be defective, and specifically excludes liability for any incidental or consequential loss or damage.*