

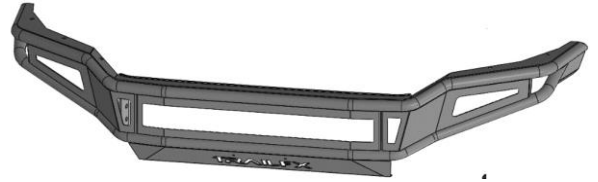

NB3 FRONT BUMPER

Part No. FPRB001TI



Fits: 2016-2021 TOYOTA TACOMA



Including Diesel models with DEF tanks



REMOVE CONTENTS FROM BOX. VERIFY ALL PARTS ARE PRESENT.



READ INSTRUCTIONS CAREFULLY BEFORE STARTING INSTALLATION.

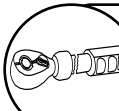

DO NOT OVER TORQUE. STANDARD OPERATING LOAD FOR TIGHTENING BODY MOUNT NUTS & BOLTS IS 8 FOOT POUND FOR M6, 18 FOOT POUND FOR M8, 37 FOOT POUND FOR M10 AND 65 FOOT POUND FOR M12



60-180 min



Cutting is not Required



Drilling is not Required



support@trailfx.com



1- (866) 638 - 4870



POWDER COATED BLACK – 3 YEARS

PARTS LIST:

Qty	Part Description	Qty	Part Description
1	NB3 Front Bumper	12	10mm x 24mm OD x 2.2mm Flat Washers
1	NB3 Skid Plate	6	10mm Lock Washers
1	Driver/Left Mounting Bracket	6	10mm Hex Nuts
1	Passenger/Right Mounting Bracket	8	8mm x 25mm Button Head Bolts
1	Driver/Left Fill Panel	10	8mm x 20mm Hex Bolts
1	Passenger/Right Fill Panel	2	8mm x 16mm Hex Bolts
1	Cover Panel	30	8mm x 24mm OD x 2mm Flat Washers
1	Mesh Panel	12	8mm Lock Washers
4	L-Brackets	8	8mm Hex Nuts
1	License Plate Bracket	6	8mm Flange Hex Nuts
2	License Plate Plugs	2	6mm x 20mm Button Head Bolts
2	12mm x 120mm Hex Bolts	4	6mm x 18mm OD x 1.6mm Flat Washers
4	12mm 32mm OD x 3mm Flat Washers	2	6mm Nylon Lock Nuts
2	12mm Nylon Lock Nuts	1	5mm Hex Wrench
6	10mm x 40mm Hex Bolts	1	4mm Hex Wrench

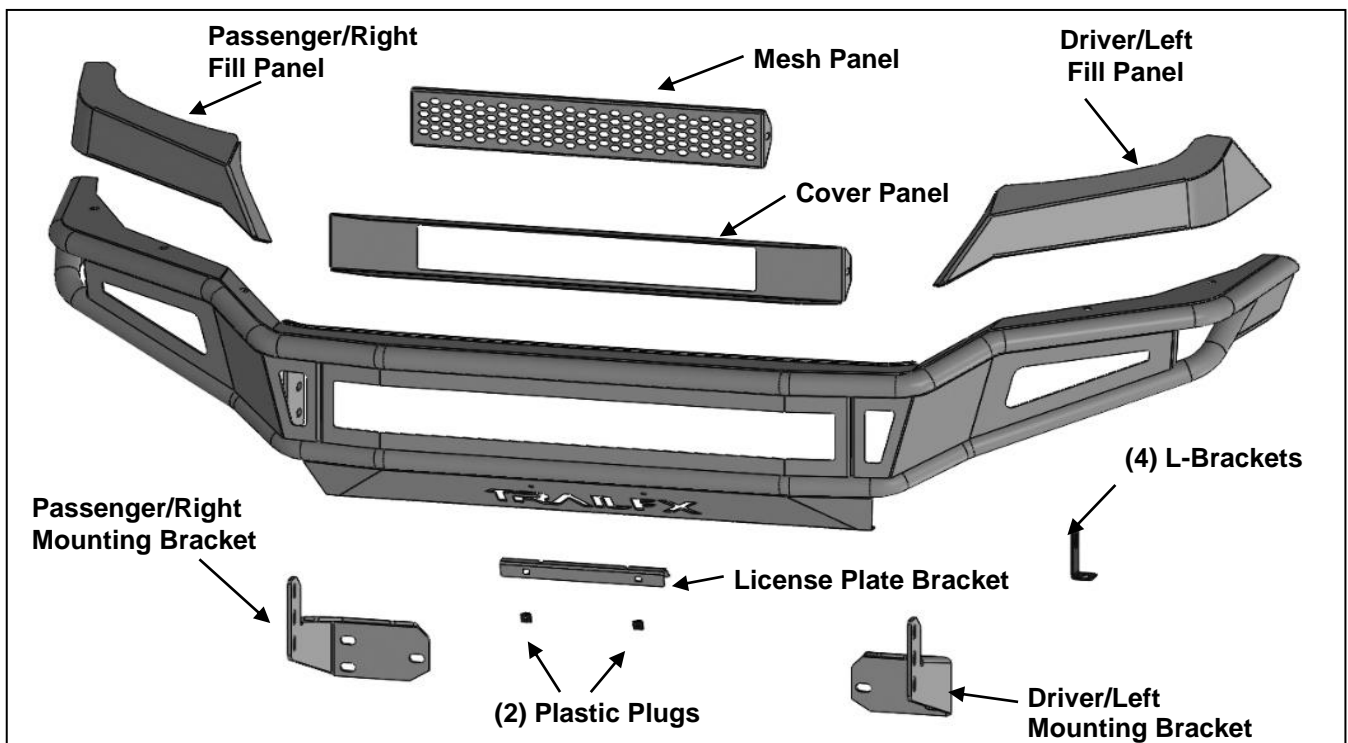

PROCEDURE:

REMOVE CONTENTS FROM BOX. VERIFY ALL PARTS ARE PRESENT. READ INSTRUCTIONS CAREFULLY BEFORE STARTING INSTALLATION. BUMPER IS HEAVY, ASSISTANCE IS HIGHLY RECOMMENDED TO AVOID POSSIBLE INJURY OR DAMAGE TO THE VEHICLE. CUTTING IS REQUIRED.

1. Remove the license plate and bracket. Open the hood and remove the plastic cover from the top of the radiator and grille, **(Figure 1)**. Next, carefully remove the plastic grille, **(Figure 2)**. Remove the air dam from the bottom of the bumper.
2. On models with factory fog lights, unplug the harness leading to the lights. Release the wiring harness from the clips attached to the back of the bumper. Move harness away from bumper.
3. Carefully pull the front leading end of the fender flares outward to release from the bumper cover, **(Figure 3)**. The flares do not need to be completely removed, only release the front portion and leave the rest of the flare attached.
4. Remove the hardware attaching the plastic bumper cover at the top, ends and bottom. With assistance, pop the ends off of the inner clip and pull the bumper off of the vehicle. Remove the plastic bumper mount from below the headlights, **(Figure 3)**.
5. Reinstall the factory hardware to secure the headlights to the vehicle. Do not reinstall the plastic blocks, only reinstall the hardware. Reinstall the grille and cover removed in **Step 1**.
6. Remove the plastic impact pads, aluminum inner impact bumper and brackets from the end of the frame, **(Figures 4 & 5)**. Next, remove the plastic splash guards from both sides.
7. Select the Passenger/Right Mounting Bracket. Reuse the factory hex nuts to attach the Bracket to the end of the frame, **(Figures 6 & 7)**. Repeat to attach the Driver/Left Bracket. Do not tighten hardware.
8. Select the Passenger/Right Fill Panel, **(Figure 8)**. Attach the Panel to the top of the Bumper with (3) 8mm x 20mm Hex Bolts, (3) 8mm Flat Washers and (3) 8mm Flange Hex Nuts. Line up the edges of the Panel with the Bumper and tighten hardware. Repeat this Step to attach the Driver/Left Fill Panel.
9. **Determine if Mesh Panel or light or will be installed. (light not included)**

For Cover and Mesh Panels installation

- a. Select (4) L-Brackets. Attach the L-Brackets to the back of the NB3 Bumper with (4) 8mm x 25mm Button Head Bolts, (8) 8mm Flat Washers, (4) 8mm Lock Washers and (4) 8mm Hex Nuts, **(Figure 9)**.
- b. Select the Cover Panel.
- c. Attach the Panel to the outer (2) L-Brackets on the back of the Bumper with (2) 8mm x 20mm Hex Bolts, (4) 8mm Flat Washers, (2) 8mm Lock Washers and (2) 8mm Hex Nuts, **(Figure 10)**.
- d. Select the Mesh Panel.
- e. Attach Panel to the inner (2) L-Brackets with (2) 8mm x 20mm Hex Bolts, (4) 8mm Flat Washers, (2) 8mm Lock Washers and (2) 8mm Hex Nuts, **(Figure 11)**. Do not tighten hardware.
- f. Continue to **Step 9**.

For 20inch Light Bar installation (Light not included)

- a. Select (4) L-Brackets. Attach the L-Brackets to the back of the NB3 Bumper with (4) 8mm x 25mm Button Head Bolts, (8) 8mm Flat Washers, (4) 8mm Lock Washers and (4) 8mm Hex Nuts, **(Figure 9)**.
- b. Select the Cover Panel.
- c. Attach the Panel to the outer (2) L-Brackets on the back of the Bumper with (2) 8mm x 20mm Hex Bolts, (4) 8mm Flat Washers, (2) 8mm Lock Washers and (2) 8mm Hex Nuts, **(Figure 10)**.
- d. Attach Light Bar (not Included) to the inner (2) L-Brackets with (2) 8mm x 16mm Hex Bolts, (2) 8mm Lock Washers and (2) 8mm Flat Washers, **(Figure 12)**. Do not tighten hardware.
- e. Continue to **Step 9**.

For 30inch Light Bar installation (Light not included)

- a. Select (2) L-Brackets. Attach the L-Brackets to the back of the NB3 Bumper with (2) 8mm x 25mm Button Head Bolts, (4) 8mm Flat Washers, (2) 8mm Lock Washers and (2) 8mm Hex Nuts, **(Figure 9)**.
 - b. Only attach the outer (2) L-Brackets to the back of the Bumper.
 - c. Attach Light Bar (not included) to the outer (2) L-Brackets with (2) 8mm x 16mm Hex Bolts, (2) 8mm Lock Washers and (2) 8mm Flat Washers. Do not tighten hardware.
 - d. Continue to **Step 9**.
10. With assistance, position the Bumper Assembly up to the inside of the Mounting Brackets. Temporarily support the weight of the Bumper. **WARNING:** To avoid possible injury or damage to the vehicle, do not proceed until the bumper is fully and safely supported. Attach the Bumper to the Mounting Brackets with (6) 10mm x 40mm Hex Bolts, (12) 10mm Flat Washers, (6) 10mm Lock Washers and (6) 10mm Hex Nuts, **(Figure 13)**. Do not tighten hardware.
 11. Level and adjust the NB3 Bumper and fully tighten all hardware.
 12. Cover the Passenger/Right plastic fender flare with removable tape, (masking tape for example). Hold the fender flare in position on the fender and over the end of the Bumper. Draw a straight line onto the tape to match where the end of the fender and Bumper meet, **(Figure 14)**. Use a sharp knife or hacksaw blade to

carefully cut the leading end off of the flare along the line. Reattach the fender flare to the fender. Repeat to cut the Driver/Left fender flare.

13. Attach the License Plate Bracket to the holes in the lower NB3 Bumper with (2) 6mm Button Head Bolts, (4) 6mm Flat Washers and (2) 6mm Nylon Lock Nuts, **(Figure 15)**. Insert (2) Plastic Plugs into the square holes in the Bracket. **(Figure 16)**.
14. **NB3 Skid Plate installation**, carefully unwrap the NB3 Skid Plate. With assistance, line up the front of the Skid Plate with the back of the Bumper. Attach the Skid Plate to the Bumper with (4) 8mm Button Head Bolts, (4) 8mm Lock Washers and (4) 8mm Flat Washers, **(Figure 17)**. Do not tighten hardware.
15. Attach the mounting tabs on the Skid Plate to the large holes in the front of the frame with (2) 12mm x 120mm Hex Bolts, (4) 12mm Flat Washers and (2) 12mm Nylon Lock Nuts, **(Figures 18—20)**.
16. Level and adjust the Skid Plate and fully tighten all hardware. **NOTE:** Do not overtighten lower hex bolts or damage to the frame may result.
17. Do periodic inspections to the installation to make sure that all hardware is secure and tight.

To protect your investment, Do not use any type of polish or wax that may contain abrasives that could damage the finish. Mild soap may be used to clean the Bumper assembly.

Passenger/Right Side Installation Pictured



(Fig 1) Remove plastic cover from top of radiator



(Fig 2) Remove grille, air dam from below bumper and license plate. Remove plastic bumper cover



(Fig 3) Remove plastic block from front edge of fender. NOTE: Reinstall hardware to secure headlight. Reinstall grille and cover

WARNING! Do not crawl under bumper unless it is properly supported on blocks or stands or the bumper may fall.

Passenger/Right Side Installation Pictured



(Fig 4) Remove plastic impact bumper and aluminum crossbar from bumper brackets

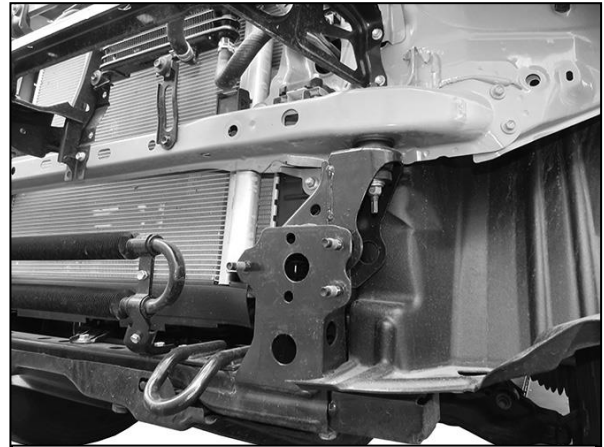

(Fig 5) Remove impact bumper and brackets

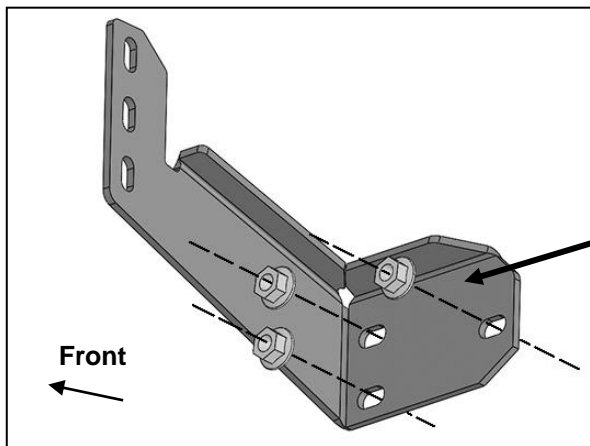

(Fig 6) Attach Passenger/Right Mounting Bracket to the mounting location

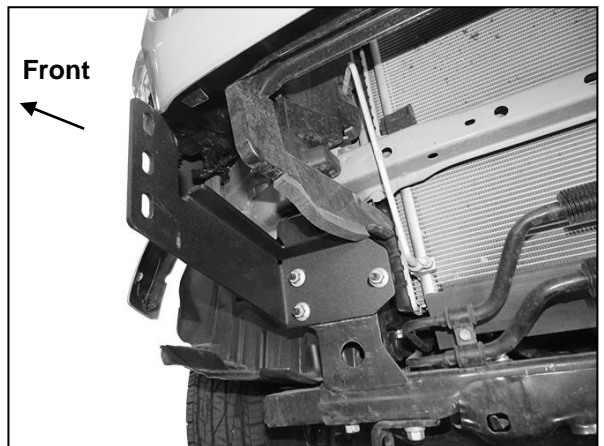

(Fig 7) Passenger/Right Mounting Bracket attach to the mounting location

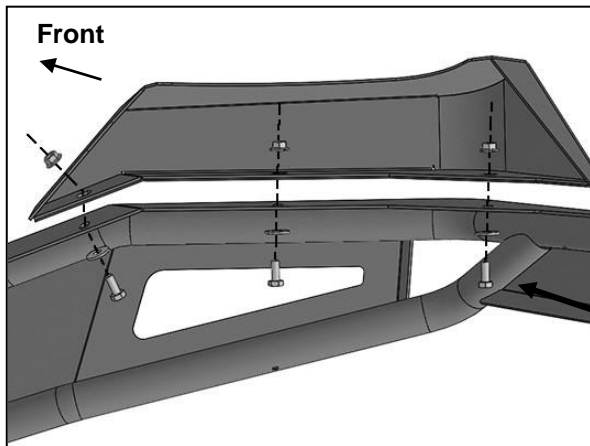

(Fig 8) Attach Fill Panel to top of Bumper

Passenger/Right Side Installation Pictured

- (2) 8mm x 25mm Button Head Bolts
- (4) 8mm Flat Washers
- (2) 8mm Lock Washers
- (2) 8mm Hex Nuts

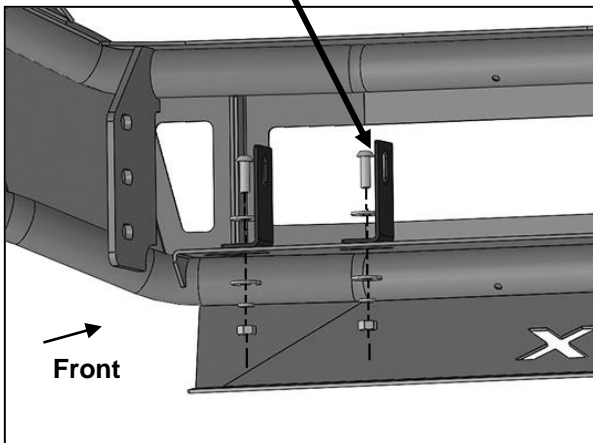

(Fig 9) Attach L-Brackets to the back of the Bumper (If installing a 30inch Light, only attach the outer L-Bracket. Light not included)

WARNING! Do not crawl under bumper unless it is properly supported on blocks or stands or the bumper may fall.

- 8mm x 20mm Hex Bolt
- (2) 8mm Flat Washers
- 8mm Lock Washer
- 8mm Hex Nut

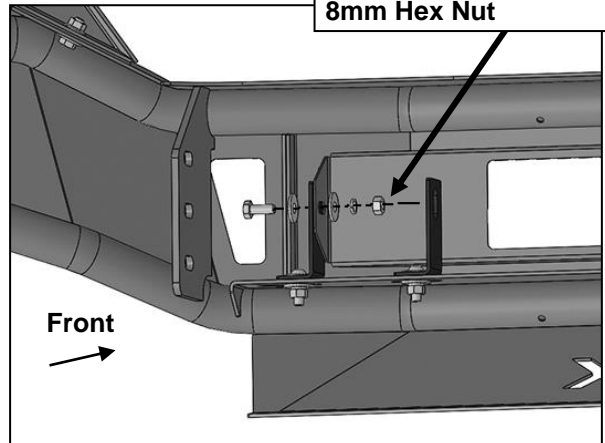

(Fig 10) Attach Cover Panel to outer L-Bracket

- 8mm x 20mm Hex Bolt
- (2) 8mm Flat Washers
- 8mm Lock Washer
- 8mm Hex Nut

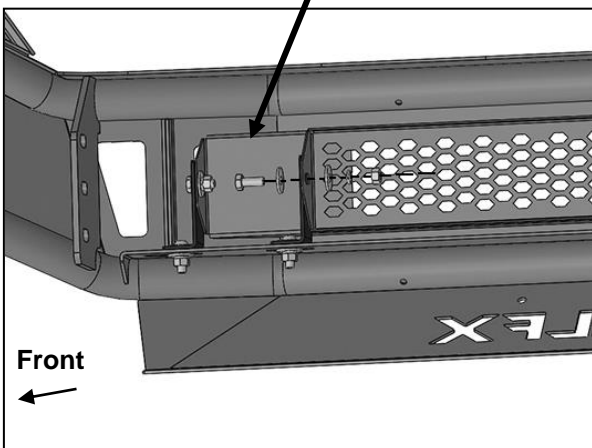

(Fig 11) Attach Mesh Panel to the inner L-Bracket

- 8mm x 16mm Hex Bolt
- 8mm Lock Washer
- 8mm Flat Washer

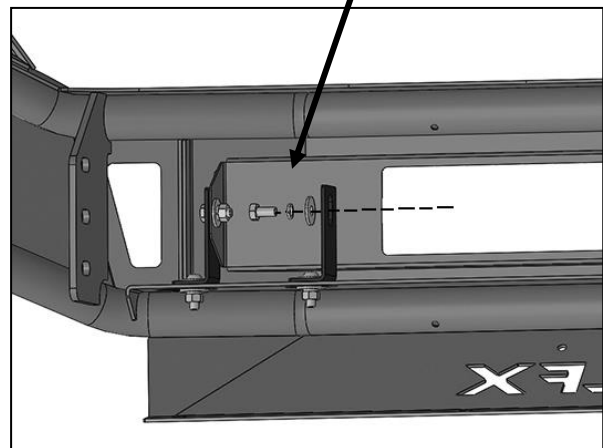

(Fig 12) Attach 20inch Light to inner L-Bracket or 30inch Light to outer L-Bracket (Lights not included)

Passenger/Right Side Installation Pictured

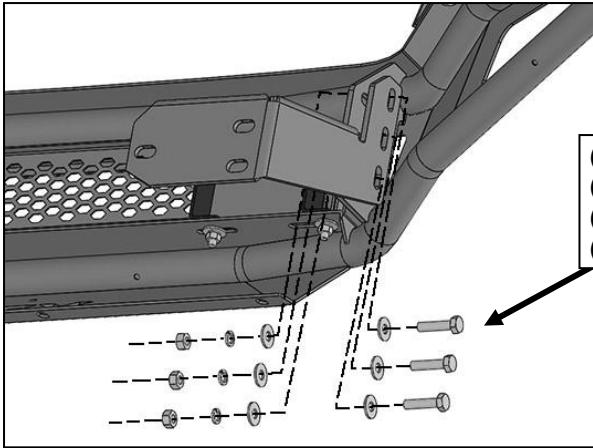

- (3) 10mm x 40mm Hex Bolts
- (6) 10mm Flat Washers
- (3) 10mm Lock Washers
- (3) 10mm Hex Nuts

(Fig 13) Attach NB3 Bumper to the Passenger/Right Mounting Bracket

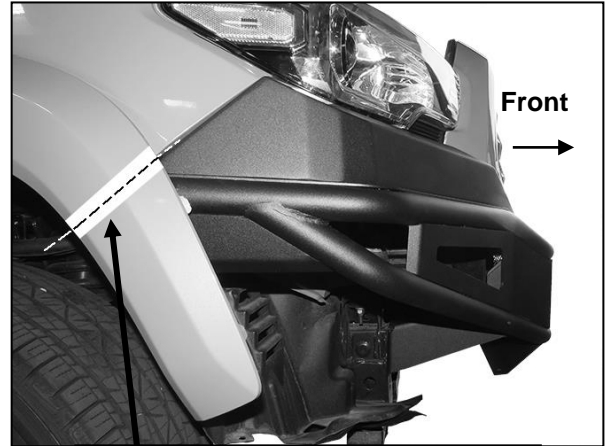

(Fig 14) Apply tape, (not included) to the fender and cut to fit Bumper

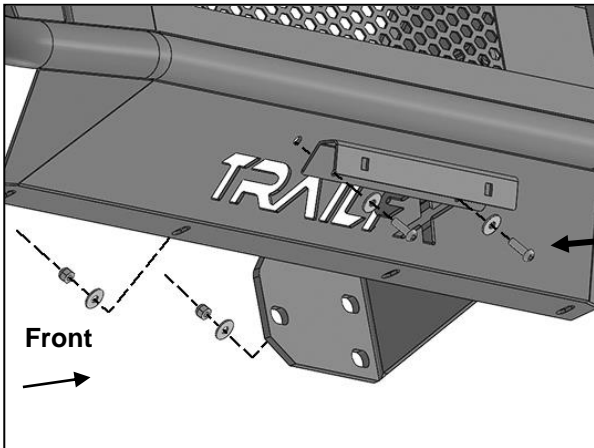

- (2) 6mm x 20mm Button Head Screws
- (4) 6mm Flat Washers
- (2) 6mm Nylon Lock Nuts

(Fig 15) Attach the License Plate Bracket to the bottom of the Bumper

- (2) Plastic Plugs

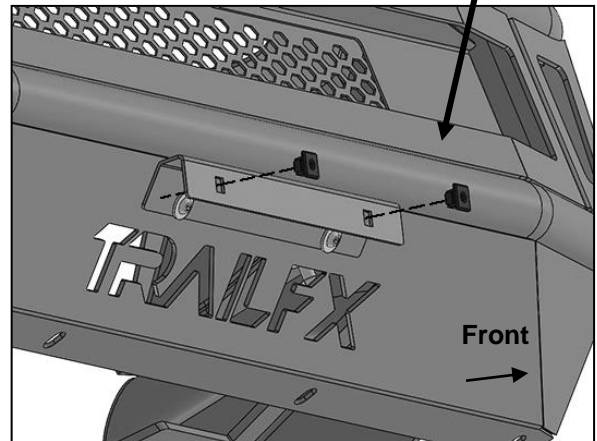

(Fig 16) Attach License Plate Bracket to Bumper

Skid Plate Installation Pictured

- (4) 8mm x 25mm Button Head Bolts
- (4) 8mm Lock Washers
- (4) 8mm Flat Washers

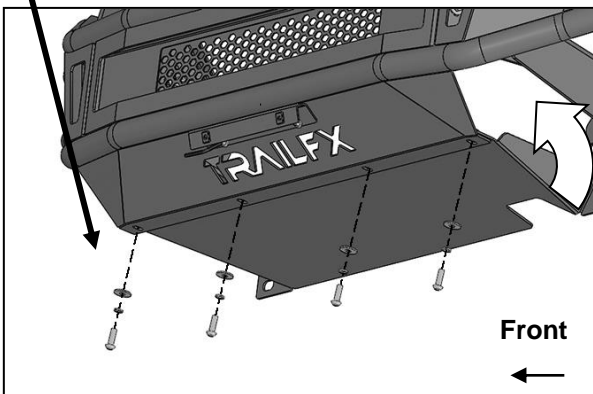

(Fig 17) Attach Skid Plate to back of Bumper

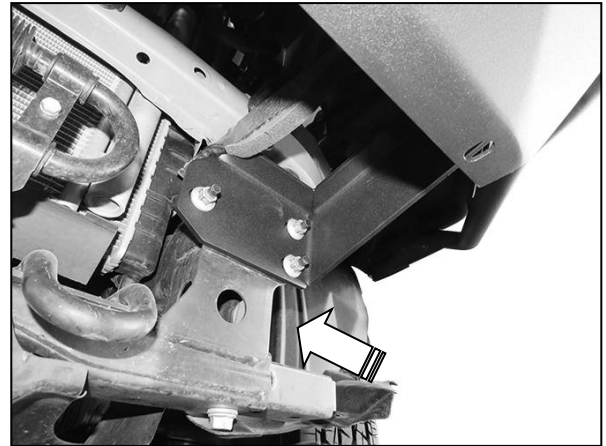

(Fig 18) Skid Plate frame mounting location

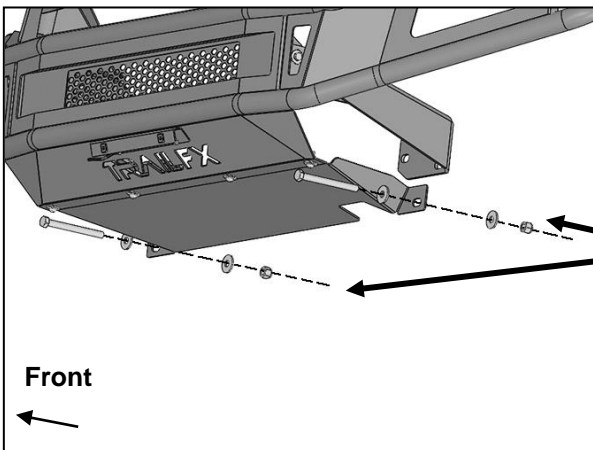

(Fig 19) Attach Skid Plate to end of frame

- (2) 12mm x 120mm Hex Bolts
- (4) 12mm Flat Washers
- (2) 12mm Nylon Lock Nuts

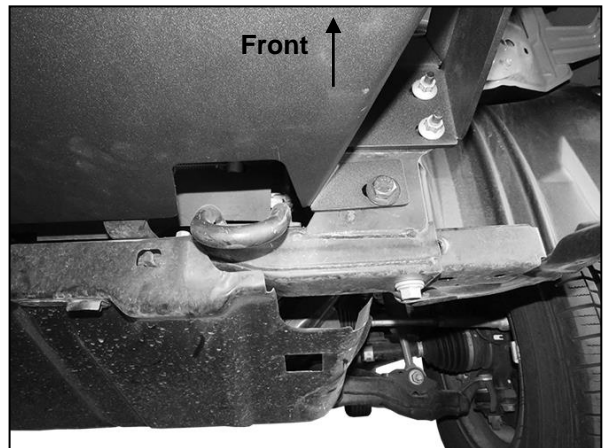

(Fig 20) Driver/left mounting tab on Skid Plate attached to frame

PRODUCT CARE

- Periodically check the product to ensure all fasteners are tight and components are intact.
- Regular waxing is recommended to protect the finish of the product.
- Use ONLY Non-Abrasive automotive wax. Use of any soap, polish or wax that contains an abrasive is detrimental and can scratch the finish leading to corrosion.
- Mild soap may be used to clean the Black finish product.

FAQ's

- 1. Hardware and mounting brackets are not aligning properly**
Ensure that hardware is being used on the correct side of the vehicle. In some cases, the hardware may appear same for driver or passenger side but may alter the alignment of mounting location. Check mounting brackets for both sides.
- 2. Bumper is not aligning with vehicle Bumper**
Brackets may be interchanged or reversed (Driver / Passenger Side). Check Brackets for each side as well ensure the proper hardware has been used for each side.
- 3. Products are thumping / rattling after installation.**
Ensure that all required mounting brackets / hardware's are installed & tighten correctly. Suggest using white lithium / regular grease between metal to metal contact.
- 4. Missing / Excess Hardware.**
Recheck hardware count as per the part list.
- 5. Product not installing properly.**
Ensure the Year / Make / Model as well as cab and bed dimensions are correct for the application. Review all steps for installation to ensure they were followed correctly.
- 6. Who should be contacted for questions regarding product / installation assistance?**
www.trailfx.com / support@trailfx.com 1-(866) 638-4870

Check out these other TrailFX Products!

www.trailfx.com



BULL BAR



GRILLE GUARDS



BED RAILS

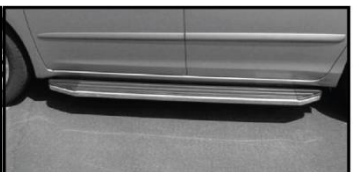

RUNNING BOARDS



RUNNING BOARDS



RUNNING BOARDS

...ree of defects in material and workmanship at the time of purchase by the
...r implied, including the warranty of fitness for a particular purpose or an
...r repair the product at our option, when the product is returned prepaid,
...f this product voids the warranty. KAO's liability is limited to repair or
...liability for any incidental or consequential loss or damage.