



1-800-366-9712

INSTALLATION INSTRUCTIONS

IMPORTANT NOTICE: Be sure to inspect and test fit product before having it coated or painted. Ranch Hand will not be responsible for the cost of the coating if any problems with fit or finish are not noted and addressed beforehand.

2017-up FORD SUPER DUTY SUMMIT FRONT BUMPERS PART # FSF201BL1 / FSF201BL1C / BSF201BL1

Warning: *If your vehicle has adaptive cruise, please ensure that your adaptive cruise is working correctly once the Ranch Hand bumper is installed. Adaptive cruise may need to be cleaned or adjusted to ensure it functions properly. See your owner's manual for care of the adaptive cruise.*

1. Unhook the fog light wiring harness.
2. Remove the side bumper bracket bolts. Two on each side.
3. If an Adaptive Cruise Control Module is present (located on the driver side) it will need to be unplugged and removed. *Note: It will be installed later.
4. Remove the factory bumper by removing the eight 18mm bolts. Four on each side.
5. Remove the tow hooks. There are four 18mm bolts holding each tow hook.
6. Note: *Before installing the mounting plates, make sure the top of the frame rails and the bottom sides of the mounting plates are free of splatter.* Slide the tow hook through the opening and mount the mounting plate over the frame. Use the tow hook bolt to install back to the frame. Use four ½" x 1 ¾" bolt, *facing towards the inside of the frame*, to mount the mounting plate to the inside of the frame. **TOW HOOKS MUST BE REINSTALLED!**



7. On trucks that have the extra towing package cooler, you will need to flatten or cut off the two tabs that hook under the frame rail. *See photo below*

----- **WARNING** -----

Special care should be exercised in the handling, storage and installation of Ranch Hand equipment.

The actual weight of each piece of equipment will vary depending on style and model. The weight of the equipment is sufficient in volume to warrant special care, assistance and in some instances, the use of mechanical equipment during the transfer and installation of the equipment. Do not assume a position directly under the equipment during installation. Be sure the equipment has been connected and stabilized during installation to prevent falling or shifting of positions.

Periodically check tightness of bolts to make sure they are tight, and unlikely to fail.

Rev. 2022



1-800-366-9712

INSTALLATION INSTRUCTIONS

IMPORTANT NOTICE: Be sure to inspect and test fit product before having it coated or painted. Ranch Hand will not be responsible for the cost of the coating if any problems with fit or finish are not noted and addressed beforehand.

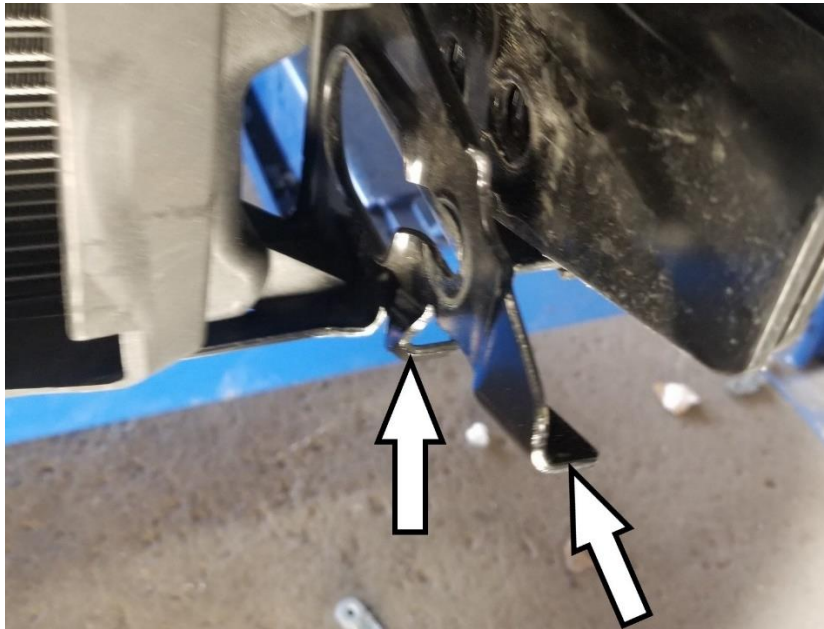

8. Make sure the holes of the tow hook bracket and the holes of the mounting plate line up.
9. Mount the front bumper replacement to the mounting plates by using the ½” x 2” bolts.

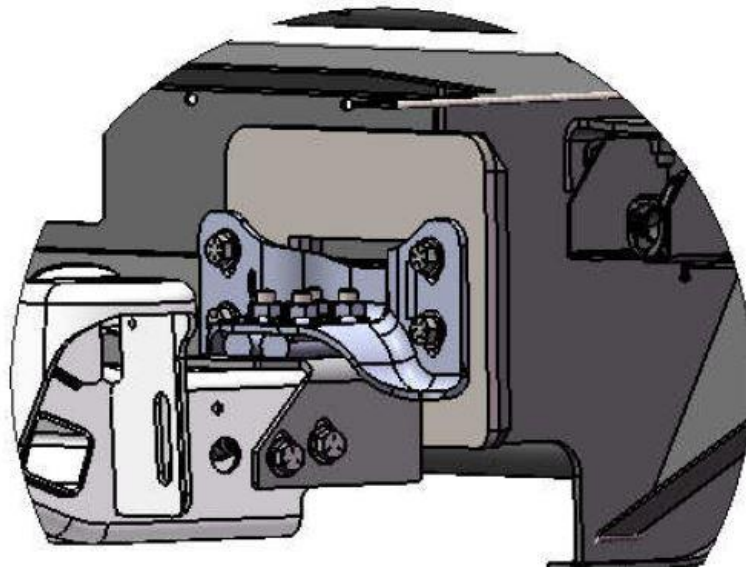

10. Center the front end from side to side and raise or lower the front end as needed.
11. **2017-19 models:** Mount the Adaptive Cruise Control Module to the Adaptive Cruise Bracket (FSF15HACBBL) provided. Use the ¼” x 1 ½” bolts provided. Use the four plastic spacers

----- WARNING -----

Special care should be exercised in the handling, storage and installation of Ranch Hand equipment. The actual weight of each piece of equipment will vary depending on style and model. The weight of the equipment is sufficient in volume to warrant special care, assistance and in some instances, the use of mechanical equipment during the transfer and installation of the equipment. Do not assume a position directly under the equipment during installation. Be sure the equipment has been connected and stabilized during installation to prevent falling or shifting of positions. Periodically check tightness of bolts to make sure they are tight, and unlikely to fail.
Rev. 2022



1-800-366-9712

INSTALLATION INSTRUCTIONS

IMPORTANT NOTICE: Be sure to inspect and test fit product before having it coated or painted. Ranch Hand will not be responsible for the cost of the coating if any problems with fit or finish are not noted and addressed beforehand.

between the adaptive cruise bracket and the rectangle plastic cover. Mount the bracket to the angle iron that is located on the underside of the top plate with 5/16" bolts. The A.C.C. module will face forwards.

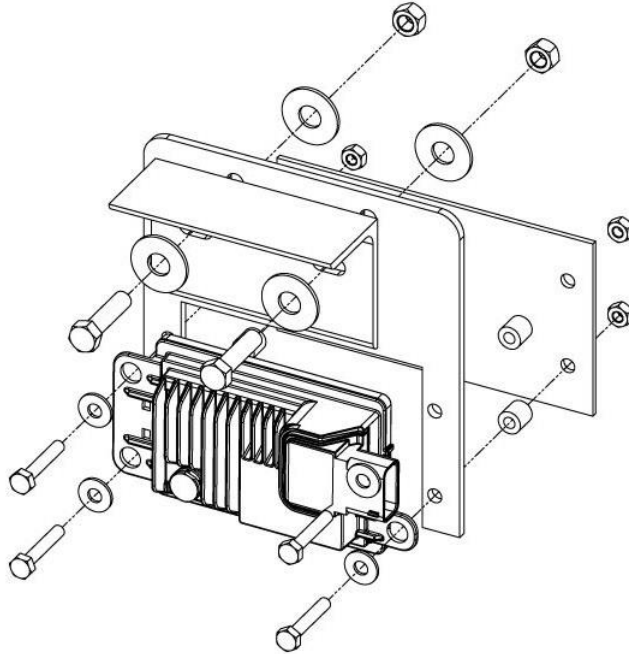

12. **2020-up models:** Mount the Adaptive Cruise Control Module to the Adaptive Cruise Bracket (FBF18HACBBL for 2020-up models). Use the 1/4" x 1" bolts provided. Mount the bracket to the front side of the angle iron that is located on the underside of the top plate with 5/16" bolts. The A.C.C. module will face forwards.



----- WARNING -----

Special care should be exercised in the handling, storage and installation of Ranch Hand equipment.

The actual weight of each piece of equipment will vary depending on style and model. The weight of the equipment is sufficient in volume to warrant special care, assistance and in some instances, the use of mechanical equipment during the transfer and installation of the equipment. Do not assume a position directly under the equipment during installation. Be sure the equipment has been connected and stabilized during installation to prevent falling or shifting of positions.

Periodically check tightness of bolts to make sure they are tight, and unlikely to fail.

Rev. 2022



1-800-366-9712

INSTALLATION INSTRUCTIONS

IMPORTANT NOTICE: Be sure to inspect and test fit product before having it coated or painted. Ranch Hand will not be responsible for the cost of the coating if any problems with fit or finish are not noted and addressed beforehand.

MAKE SURE ALL NUTS AND BOLTS ARE TIGHT!

Troubleshooting Adaptive Cruise:

1. *Make sure A.C.C. module is installed properly and plugged in.*
2. *Make sure module bracket is bolted to the FRONT side of the angle iron. Burrs on the back side of the angle iron may cause A.C.C. module to not sit straight.*
3. *The angle iron should be parallel to the pipe and front insert. If it is welded at an angle, it will cause adaptive Cruise not to function properly.*

----- **WARNING** -----

Special care should be exercised in the handling, storage and installation of Ranch Hand equipment.

The actual weight of each piece of equipment will vary depending on style and model. The weight of the equipment is sufficient in volume to warrant special care, assistance and in some instances, the use of mechanical equipment during the transfer and installation of the equipment. Do not assume a position directly under the equipment during installation. Be sure the equipment has been connected and stabilized during installation to prevent falling or shifting of positions.

Periodically check tightness of bolts to make sure they are tight, and unlikely to fail.

Rev. 2022