



# Replacement Front Bumper

## Part No. FX3008



Fits: 2010-Current

Dodge Ram 2500/3500 HD



ASSISTANCE IS RECOMMENDED.



REMOVE CONTENTS FROM BOX. VERIFY ALL PARTS ARE PRESENT.



READ INSTRUCTIONS CAREFULLY BEFORE STARTING INSTALLATION.

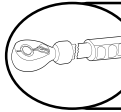

DO NOT OVER TORQUE. STANDARD OPERATING LOAD FOR TIGHTEN BODY MOUNT NUTS & BOLTS VARIES FROM 45 TO 65 FOOT POUND.



60-180 min



Cutting Not Required



Drilling Not Required



[support@trailfx.com](mailto:support@trailfx.com)



1 866 638 4870



**WARRANTY**  
POLISHED STAINLESS STEEL – LIMITED LIFETIME  
POWDER COATED BLACK – 3 YEARS

### PARTS LIST:

Qty	Part Description	Qty	Part Description
1	Replacement Bumper	2	Mounting Brackets
4	5x20mm Phillips Screws	8	5x15x1.2mm Flat Washers
4	5mm Lock Washers	4	5mm Hex Nuts
4	12x110mm Hex Bolts	8	12x37x3mm Flat Washers
4	12mm Lock Washers	4	12mm Hex Nuts

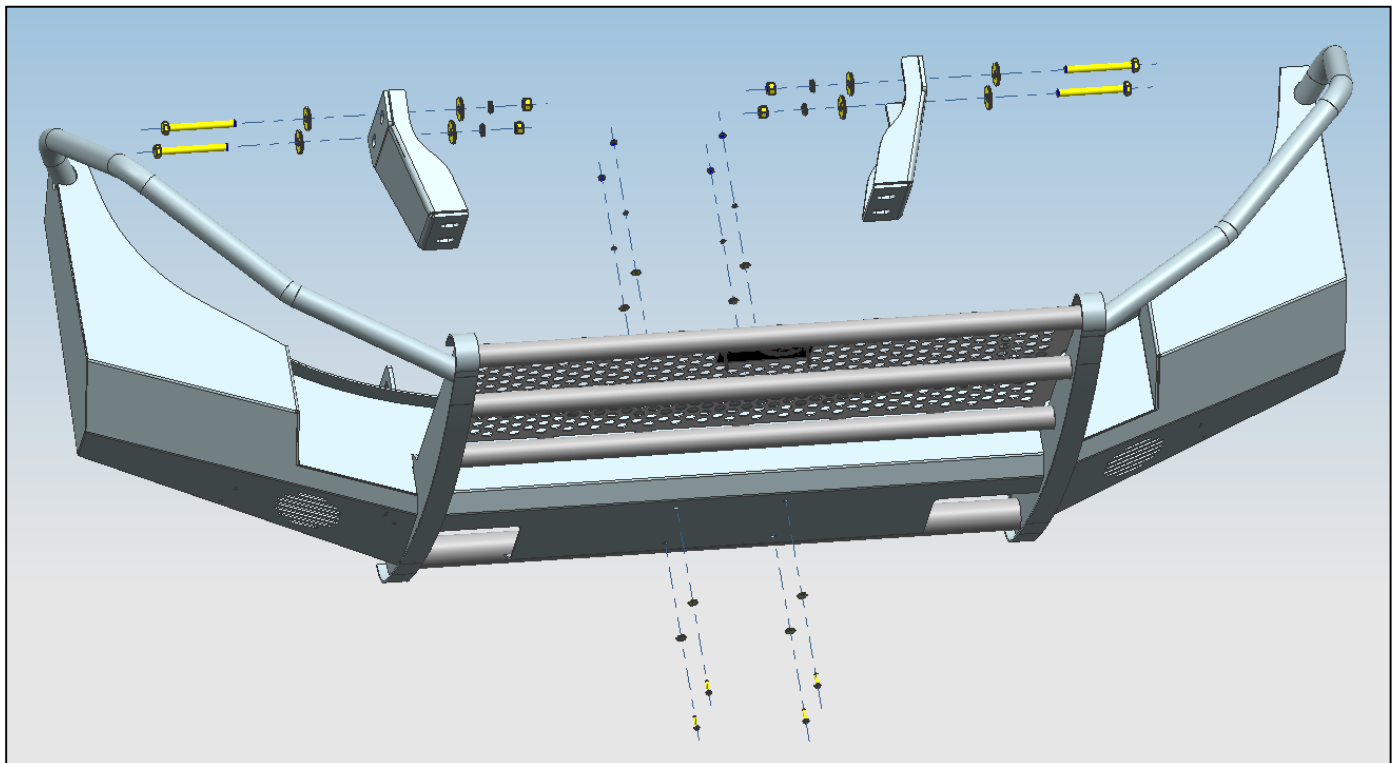

## INSTALLATION PROCEDURE

**BUMPER IS HEAVY, ASSISTANCE IS HIGHLY RECOMMENDED TO AVOID POSSIBLE INJURY OR DAMAGE TO THE VEHICLE.**

### Vehicle Preparation

1. Disconnect the Fog Light harness on the driver side of the OEM bumper.
2. Open Hood and Remove "Heavy Duty" Dust Shield.
3. Remove the OEM lower air Dam by popping out the plastic clips (**Fig 1 & Fig 2**).

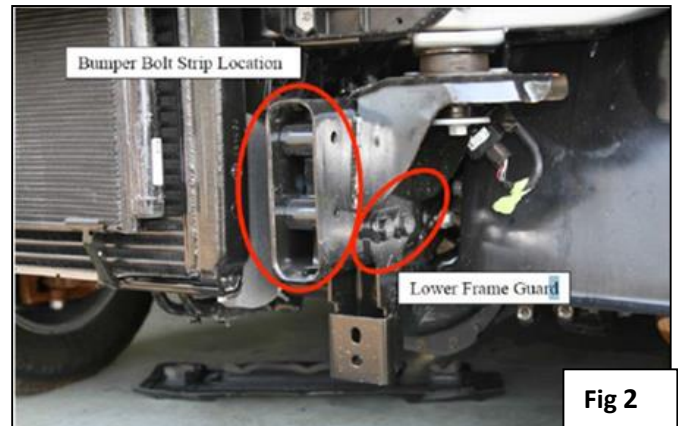

4. Diesel Models Only: Remove the 10mm bolts holding the top of the intercooler to the radiator support.
5. Remove four 18mm nuts and two bolt strip holding the OEM bumper to the frame rails. Diesel Only: Move on side of the intercooler at a time to remove the bolt strips. **BE CAREFUL NOT TO DAMAGE THE INTERCOOLER FINS.**
6. Remove the OEM Bumper and set aside.
7. Remove the OEM Tow Hooks from the bumper and keep hardware ready for reinstallation into the New Bumper.
8. Re-install the two bolts holding the top of the intercooler to the radiator supports.
9. Remove the Lower Frame Guards from using a 24mm socket and wrench.

### Bumper Installation

1. Remove the fog light from the vehicle. Use the OEM screws and nut plates to fasten the fog light to the bumper (**Fig 3**).

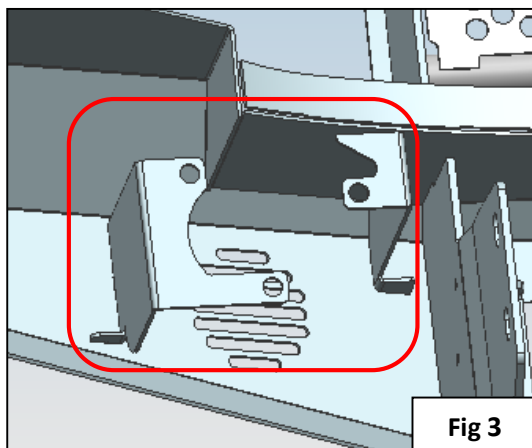

2. Attach the license plate to the Replacement Front Bumper (Fig 4). Fasten the license plate with the hardware.

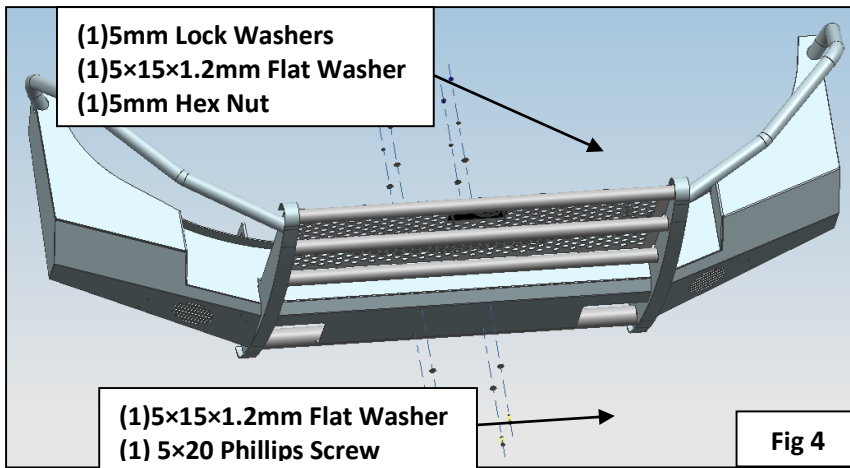

3. Install the Brackets and the Bumper to the frame. Fasten the Brackets and the Bumper with the hardware (Fig 5A & 5B).

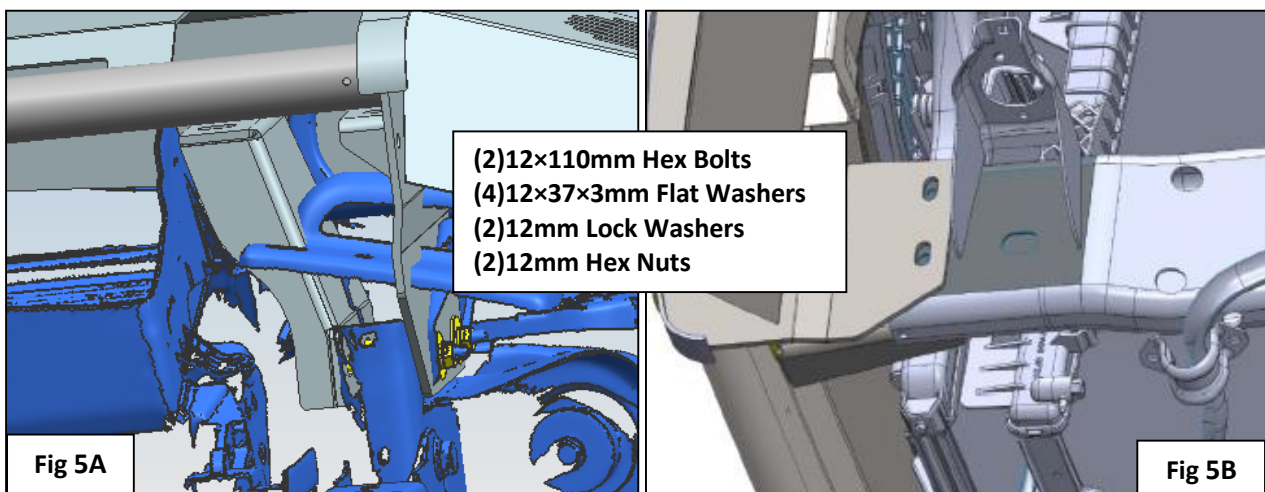

4. Use the OEM screws and nut plates to attach the tow hook to the Frame Brackets and the Mounting Brackets (Fig 6A & 6B).

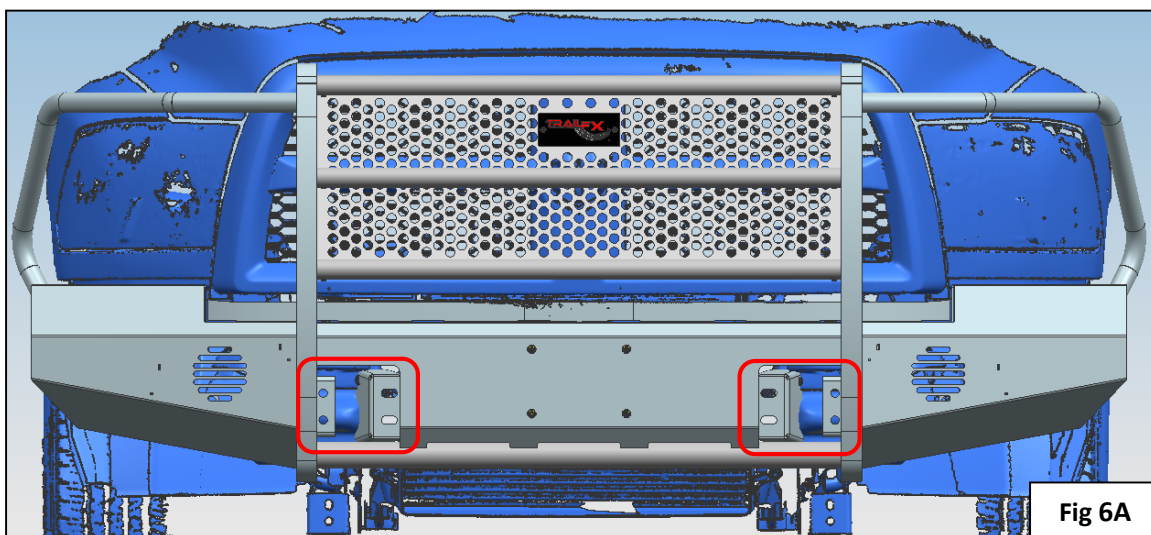

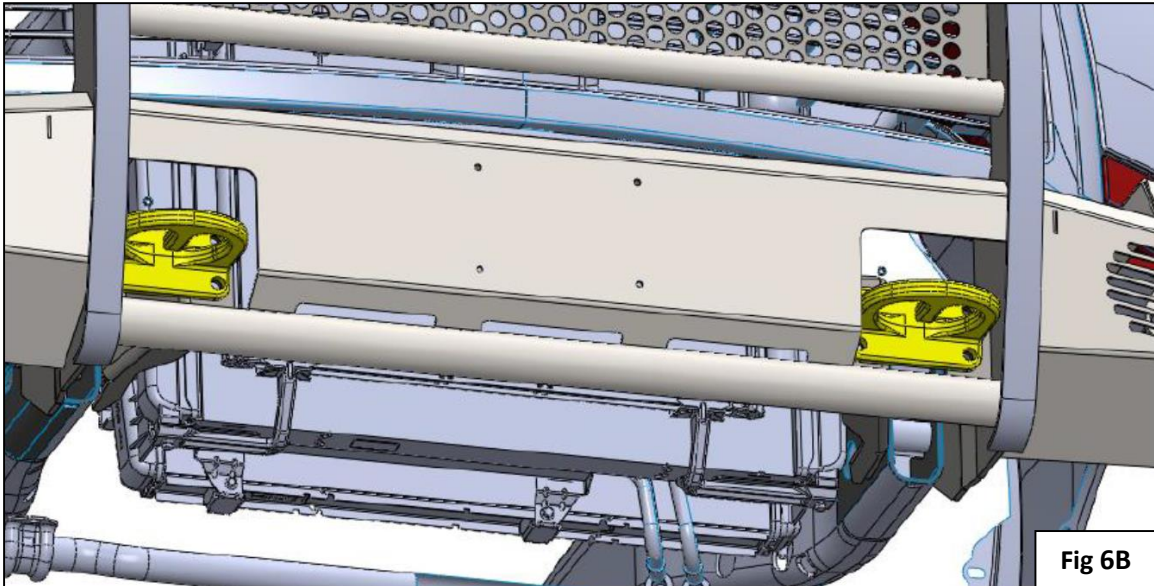

5. Reinstall the factory wiring harness to the fog light.
6. Level and adjust the bumper, make sure that all hardware is secure and tight.
7. Installation is finished, pick up all tools.

**PRODUCT CARE**

- Periodically check the product to ensure all fasteners are tight and components are intact.
- Regular waxing is recommended to protect the finish of the product.
- **Use ONLY Non-Abrasive automotive wax.** Use of any soap, polish or wax that contains an abrasive is detrimental and can scratch the finish leading to corrosion.
- Aluminum polish may be used to polish small scratches and scuffs for **Stainless Steel finish.**
- Mild soap may be used to clean the product for both **Stainless Steel and Black finish.**

**FAQ's****1. Hardware's are not of correct size.**

*In GMC / Chevrolet truck model 2006 & up, customer needs to reuse the factory body bolts to install the bracket. If your vehicle is not GMC / Chevrolet 2006 & up, ensure that holes are not partially covered with any plastic grommet or rust? If it is, remove the plastic grommet & rust from the thread holes & re-try the installation.*

**2. Mounting Bracket are not getting Installed properly.**

*In some cases Illustration images shown in Installation manual may not be the exactly same as per actual vehicle images ,also if Driver / Passenger side mounting brackets are very identical in the design, suggest referring Parts Identification guide to avoid fitment issue.*

**3. Products are thumping / rattling after installation.**

*Ensure that all required mounting brackets / hardware's are installed & tighten correctly. Suggest using white lithium / regular grease between the metal to metal contact surfaces.*

**4. Side Bar is not aligning with vehicle / Step Pads are not aligning with vehicle doors.**

*Side bar may be interchanged or mounting brackets are not installed at the correct position in the vehicle. Refer Parts identification guide.*

**5. Missing / Excess Hardware.**

*Recheck hardware count as per the part list.*

**6. Product not installing properly.**

*Ensure make model year, cab length and bed size of your vehicle is listed in the application. All installation steps are followed correctly.*

Check out these other TrailFX Products!!

www.TrailFX.com



**SIDE BAR**



**HEADACHE RACKS**



**RUNNING BOARDS**



**ROCKER GUARDS**

Keystone Automotive Operations Inc. (KAO) warrants this product to be free of defects in material and workmanship at the time of purchase by the original retail consumer. KAO disclaims any other warranties, express or implied, including the warranty of fitness for a particular purpose or an intended use. If the product is found to be defective, KAO may replace or repair the product at our option, when the product is returned prepaid, with proof of purchase. Alteration to, improper installation, or misuse of this product voids the warranty. KAO's liability is limited to repair or replacement of products found to be defective, and specifically excludes liability for any incidental or consequential loss or damage.