



Replacement Front Bumper

Part No. FX3013



Fits: 2009-2014

Ford F150



ASSISTANCE IS RECOMMENDED.



REMOVE CONTENTS FROM BOX. VERIFY ALL PARTS ARE PRESENT.



READ INSTRUCTIONS CAREFULLY BEFORE STARTING INSTALLATION.

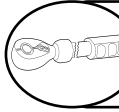

DO NOT OVER TORQUE. STANDARD OPERATING LOAD FOR TIGHTEN BODY MOUNT NUTS & BOLTS VARIES FROM 45 TO 65 FOOT POUND.



60-180 min



Cutting Not Required



Drilling Not Required



support@trailfx.com



1 866 638 4870



WARRANTY
POLISHED STAINLESS STEEL – LIMITED LIFETIME
POWDER COATED BLACK – 3 YEARS

PARTS LIST:

Qty	Part Description	Qty	Part Description
1	Replacement Bumper	2	Nut Plates
1	Driver/Left Mounting Bracket	1	Passenger/Right Mounting Bracket
4	5x20mm Phillips Screws	8	12x50mm Hex Bolts
8	5x15x1.2mm Flat Washers	10	12mm Hex Nuts
4	5mm Lock Washers	14	12mm Lock Washers
4	5mm Hex Nuts	24	12x37x3mm Flat Washers
6	12x40mm Hex Bolts		

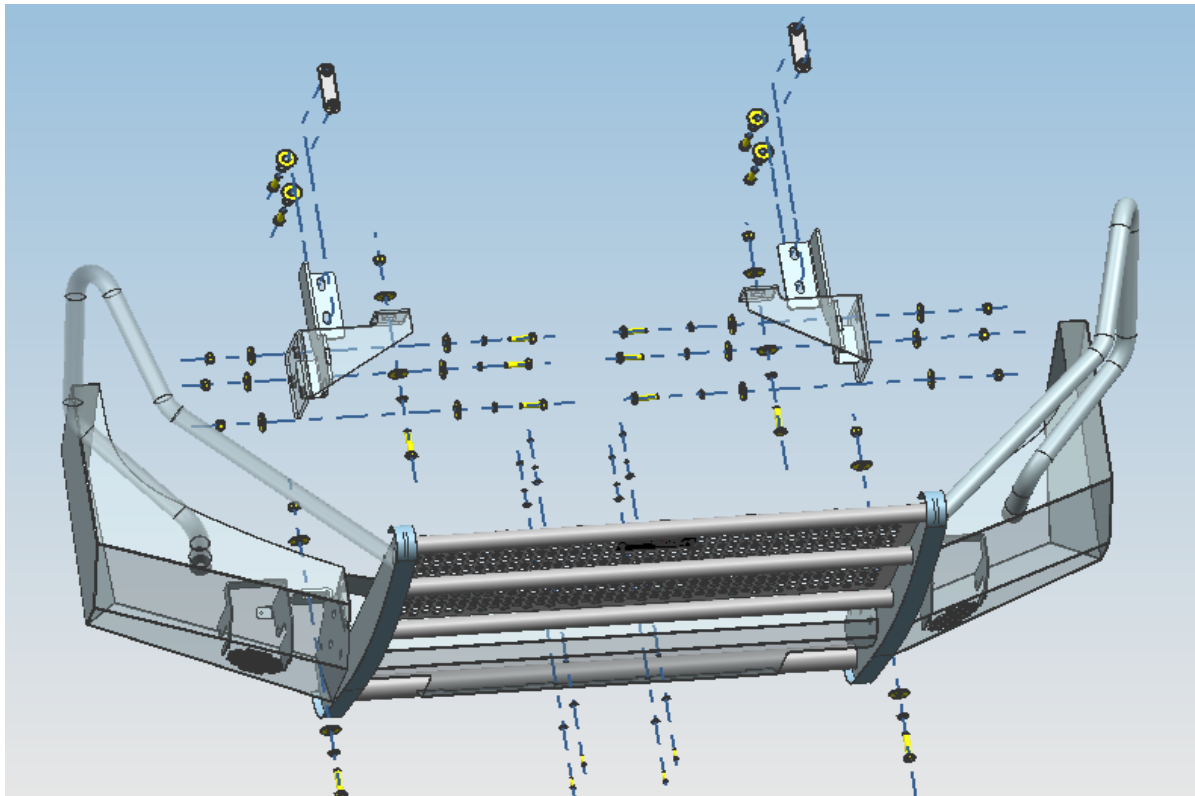

INSTALLATION PROCEDURE

BUMPER IS HEAVY, ASSISTANCE IS HIGHLY RECOMMENDED TO AVOID POSSIBLE INJURY OR DAMAGE TO THE VEHICLE.

Vehicle Preparation

1. Remove the lower air dam by loosening the fastener (14mm socket) attaching it to each frame rail behind the low hooks.
2. Remove the splash mat from the bumper by pulling out the plastic push clips.
3. If equipped, disconnect the fog lights and route the harness out of the way.
4. Open the hood and remove the lower safety latch bracket bolts that attach it to the steel portion of the OEM bumper with a 10mm socket.
5. Remove the (2) nuts from the main bumper mounting studs on each frame flange with a 21mm socket (**Fig 1A & 1B & 1C**).

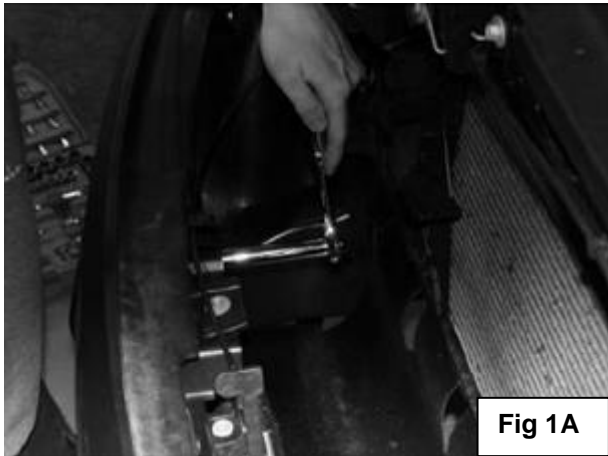

Fig 1A

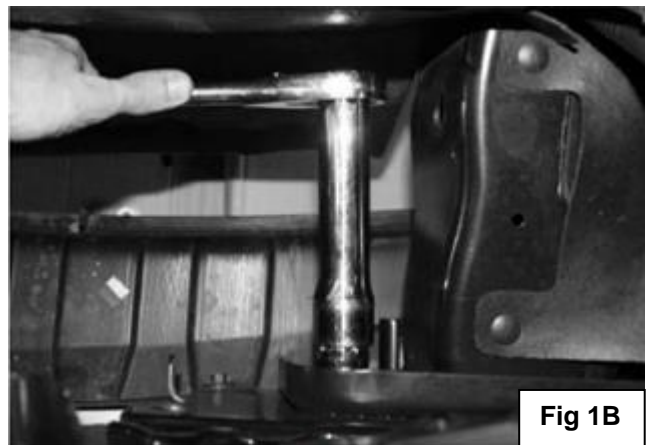

Fig 1B

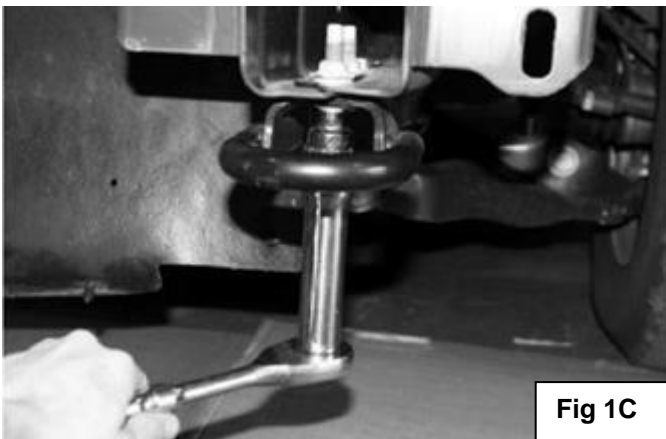
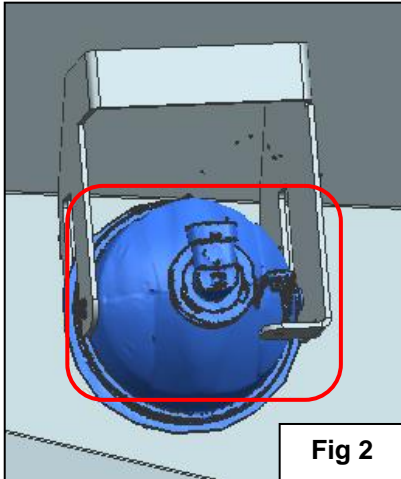

Fig 1C

6. Using two people, pull the bumper forward way from the truck. Be careful not to scratch the paint on the plastic above the bumper.
7. If equipped, remove the factory tow hooks using a 15mm socket and set aside.

Bumper Installation

1. Remove the fog light from the vehicle. Use the OEM screws and nut plates to fasten the fog light to the bumper (**Fig 2**).



2. Attach the license plate to the Replacement Bumper (**Fig 3**). Fasten the license plate with the hardware.

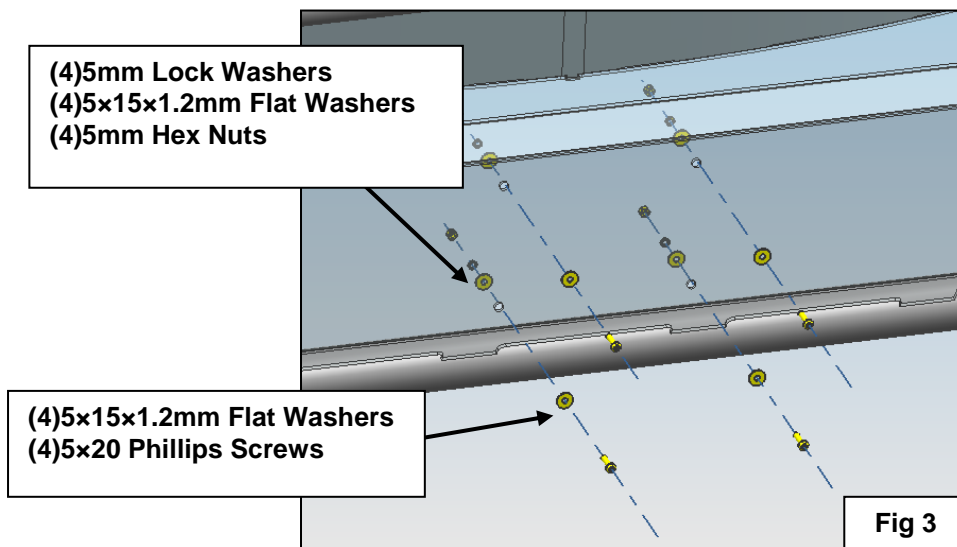

3. Fasten the Mounting Brackets to the Bumper with the hardware (**Fig 4**). Do not tighten fully at this time.

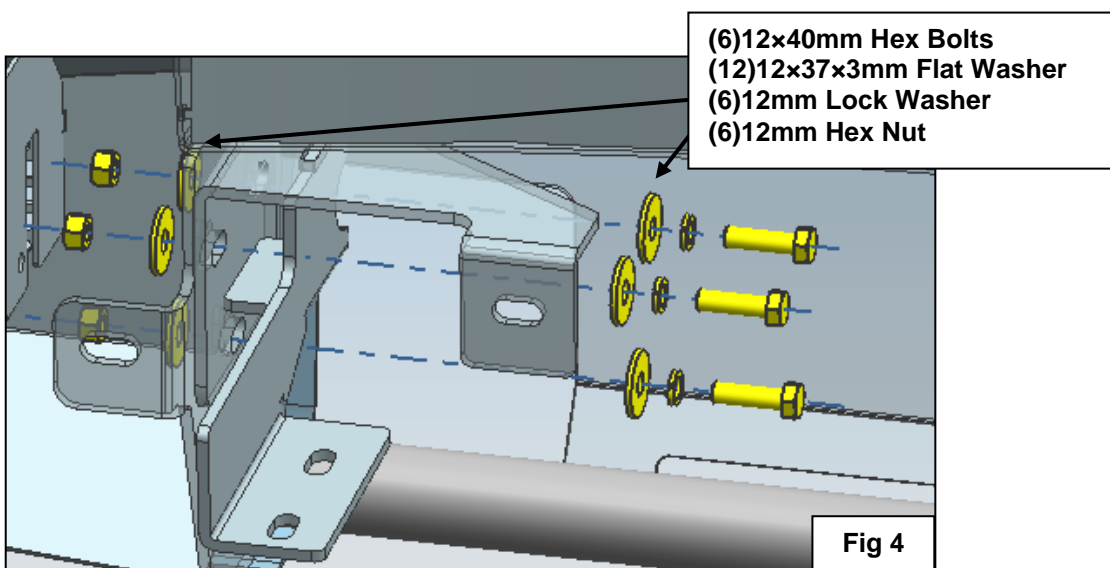

4. Attach the Bumper and the OE Tow Hook to the frame. Fasten the Bumper with the hardware (Fig 5A & 5B).

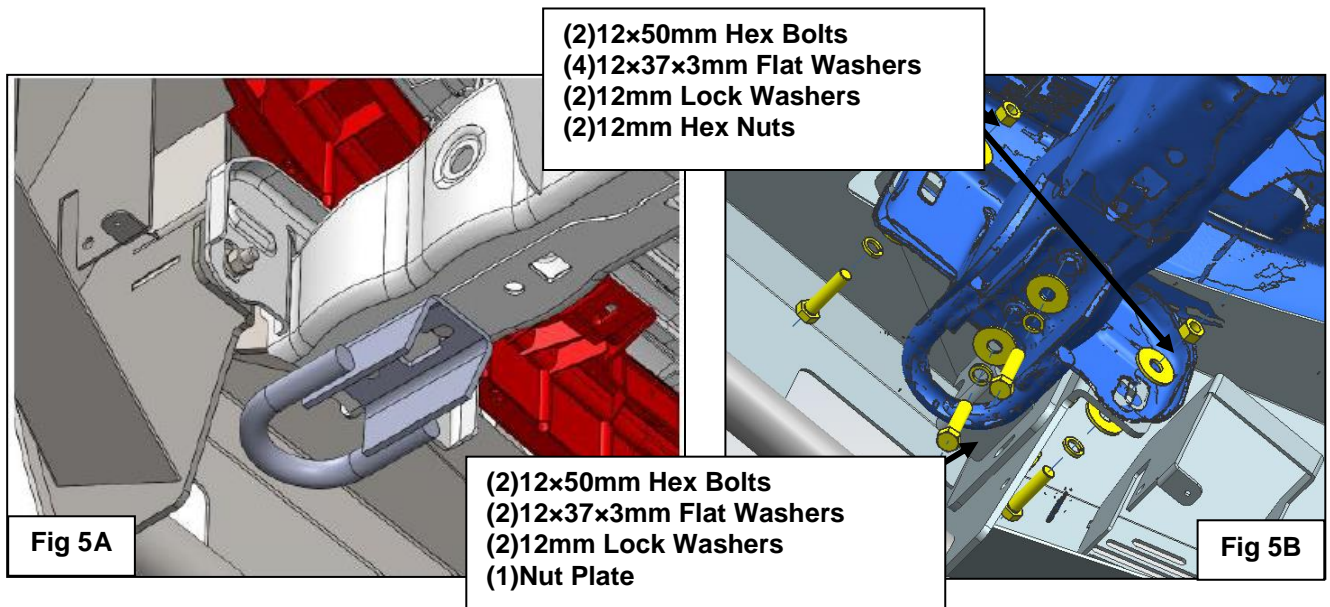

5. Reinstall the factory wiring harness to the fog light.
6. Level and adjust the bumper, make sure that all hardware is secure and tight.
7. Installation is finished, pick up all tools.

PRODUCT CARE

- Periodically check the product to ensure all fasteners are tight and components are intact.
- Regular waxing is recommended to protect the finish of the product.
- **Use ONLY Non-Abrasive automotive wax.** Use of any soap, polish or wax that contains an abrasive is detrimental and can scratch the finish leading to corrosion.
- Aluminum polish may be used to polish small scratches and scuffs for **Stainless Steel finish.**
- Mild soap may be used to clean the product for both **Stainless Steel and Black finish.**

FAQ's**1. Hardware's are not of correct size.**

In GMC / Chevrolet truck model 2006 & up, customer needs to reuse the factory body bolts to install the bracket. If your vehicle is not GMC / Chevrolet 2006 & up, ensure that holes are not partially covered with any plastic grommet or rust? If it is, remove the plastic grommet & rust from the thread holes & re-try the installation.

2. Mounting Bracket are not getting Installed properly.

In some cases Illustration images shown in Installation manual may not be the exactly same as per actual vehicle images ,also if Driver / Passenger side mounting brackets are very identical in the design, suggest referring Parts Identification guide to avoid fitment issue.

3. Products are thumping / rattling after installation.

Ensure that all required mounting brackets / hardware's are installed & tighten correctly. Suggest using white lithium / regular grease between the metal to metal contact surfaces.

4. Side Bar is not aligning with vehicle / Step Pads are not aligning with vehicle doors.

Side bar may be interchanged or mounting brackets are not installed at the correct position in the vehicle. Refer Parts identification guide.

5. Missing / Excess Hardware.

Recheck hardware count as per the part list.

6. Product not installing properly.

Ensure make model year, cab length and bed size of your vehicle is listed in the application. All installation steps are followed correctly.

Check out these other TrailFX Products!!

www.TrailFX.com



SIDE BAR



HEADACHE RACKS



RUNNING BOARDS



ROCKER GUARDS

Keystone Automotive Operations Inc. (KAO) warrants this product to be free of defects in material and workmanship at the time of purchase by the original retail consumer. KAO disclaims any other warranties, express or implied, including the warranty of fitness for a particular purpose or an intended use. If the product is found to be defective, KAO may replace or repair the product at our option, when the product is returned prepaid, with proof of purchase. Alteration to, improper installation, or misuse of this product voids the warranty. KAO's liability is limited to repair or replacement of products found to be defective, and specifically excludes liability for any incidental or consequential loss or damage.