

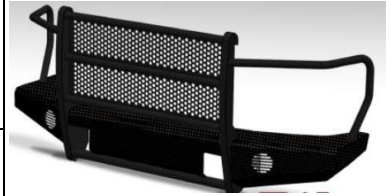

Replacement Front Bumper

Part No. FX3015



Fits: 2007 - 2013

Toyota Tundra



ASSISTANCE IS RECOMMENDED.



REMOVE CONTENTS FROM BOX. VERIFY ALL PARTS ARE PRESENT.



READ INSTRUCTIONS CAREFULLY BEFORE STARTING INSTALLATION.

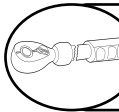

DO NOT OVER TORQUE. STANDARD OPERATING LOAD FOR TIGHTEN BODY MOUNT NUTS & BOLTS VARIES FROM 45 TO 65 FOOT POUND.



60-180 min



Cutting Not Required



Drilling Not Required



support@trailfx.com



1 866 638 4870



POLISHED STAINLESS STEEL – LIMITED LIFETIME
POWDER COATED BLACK – 3 YEARS

PARTS LIST:

Qty	Part Description	Qty	Part Description
1	Replacement Bumper	4	5mm Hex Nuts
1	Driver/Left Mounting Bracket	8	10x30x2.5mm Flat Washers
1	Passenger/Right Mounting Bracket	6	12x40mm Hex Bolts
4	5x20mm Phillips Screws	6	12mm Lock Washers
8	5x15x1.2mm Flat Washers	6	12mm Hex Nuts
4	5mm Lock Washers	12	12x37x3mm Flat Washers

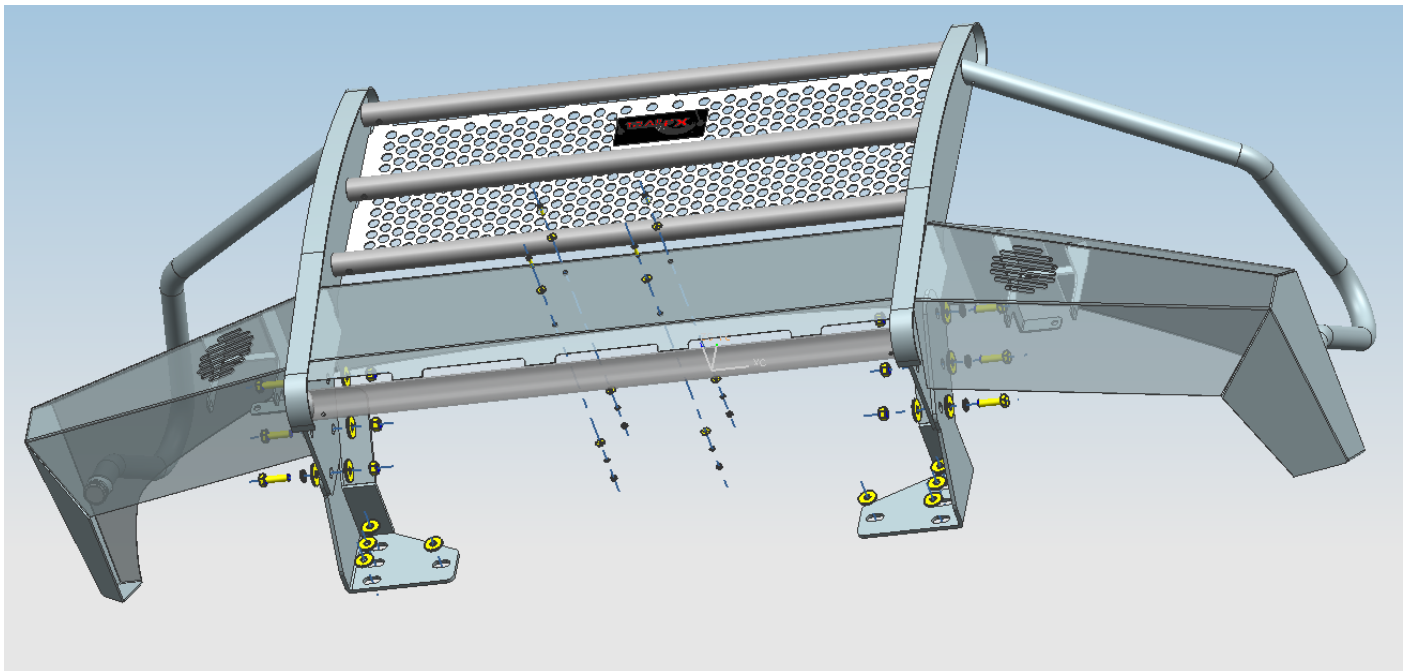

INSTALLATION PROCEDURE

BUMPER IS HEAVY, ASSISTANCE IS HIGHLY RECOMMENDED TO AVOID POSSIBLE INJURY OR DAMAGE TO THE VEHICLE.

Vehicle Preparation

1. Remove Dart Clip from front inner fender lining from frame. Complete both sides see image below.
2. Using a Phillips Head screwdriver, remove the three screws from the bottom plastic on the bumper (**Fig 1A & 1B**).

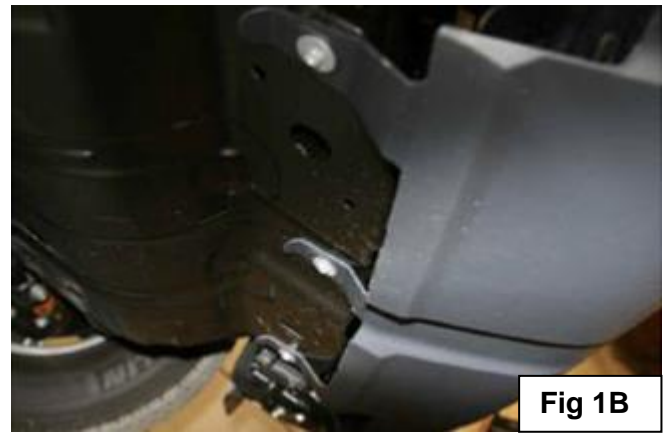

3. Remove 2 Phillips Head screws (per side) located in the inner fender well lining.
4. Disconnect the factory fog light harness from the fog lights and secure harness out of harm's way and to the frame.
5. Using a deep 14mm socket and breaker bar, loosen the four 14mm nuts located at the connection between the factory frame end and the bumper (**Fig 2**).



6. Remove the bumper by pulling forward away from the vehicle and rolling forward.
7. Remove 2 (per side) plastic clips from the painted plastic trim pieces located below the headlights. The Hood must be open for this (**Fig 3**).



8. Remove these plastic painted trim pieces by pulling directly away from the front of the truck. Keep them before complete the installation.
9. Remove all pop rivets (8 Total) from the front painted plastic bumper upper fascia (**Fig 4A & 4B**).

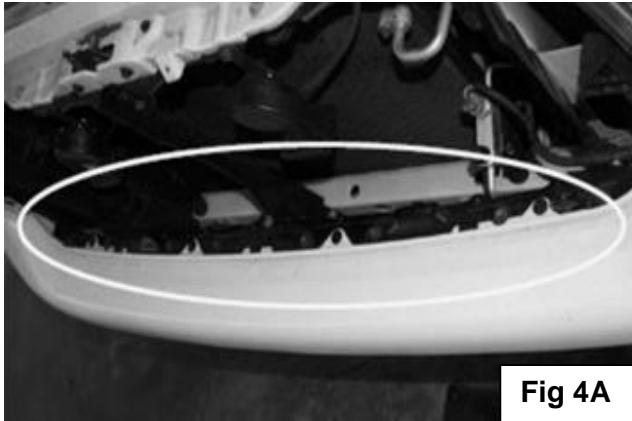

Fig 4A

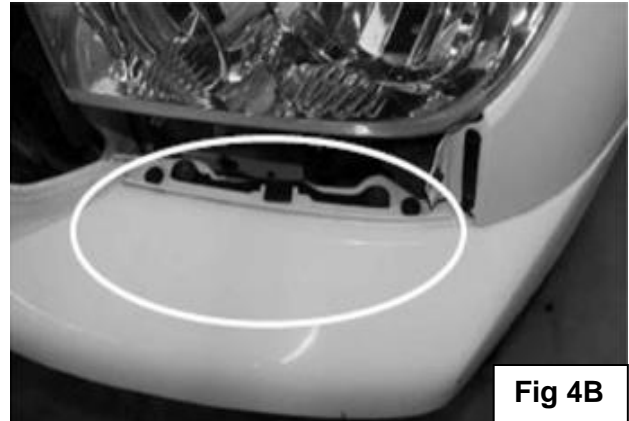

Fig 4B

10. Remove all bolts holding the painted plastic fascia piece using a 10mm socket and wrench (16 Total).
11. Remove the Phillips pop rivet holding the fascia to the inner fender. 1 per side.
12. Remove the two (one per side) 10mm screws from the recessed hole in the inner fender well.
13. Pull the edges of the plastic fascia from the truck and directly away from the front to snap free. Set fascia aside.
14. Remove the two 10mm screws using a socket from the plastic space pieces located on the lower fender. With Screws removed pull bracket straight off the truck. Complete on opposite side. See Image Below.

Bumper Installation

1. Remove the fog light from the vehicle. Use the OEM screws and nut plates to fasten the fog light to the bumper (**Fig 5A & 5B**).

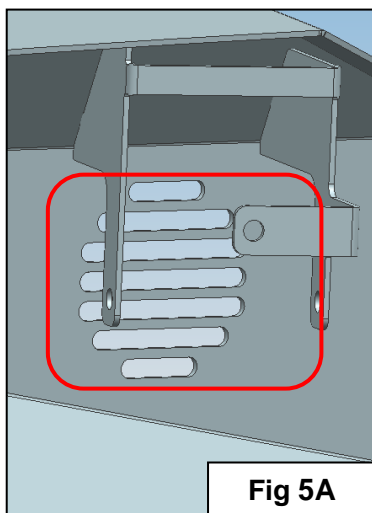

Fig 5A

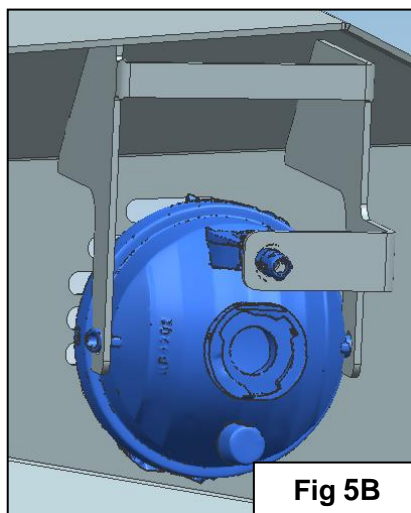
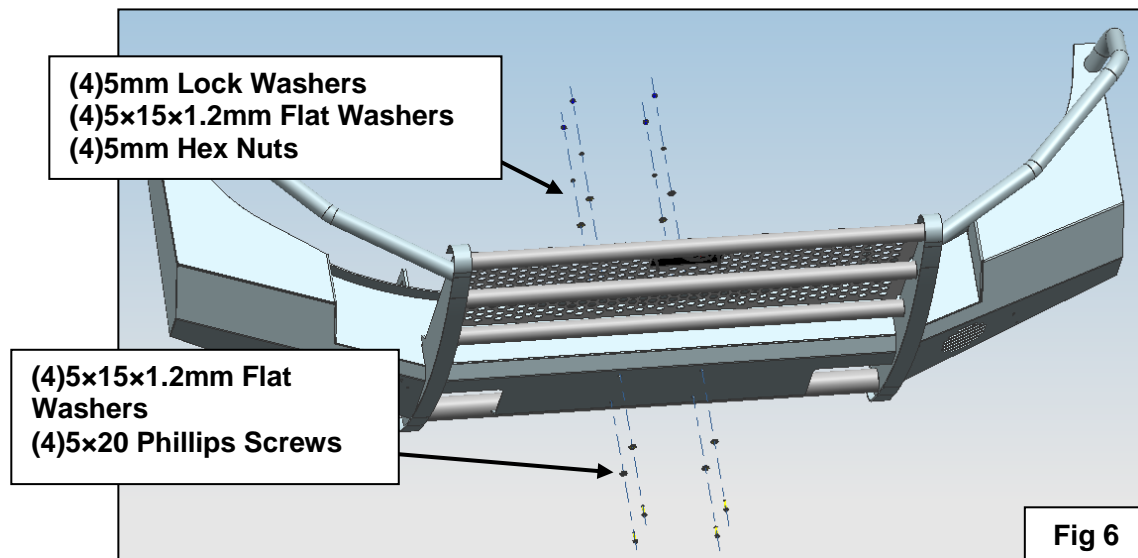
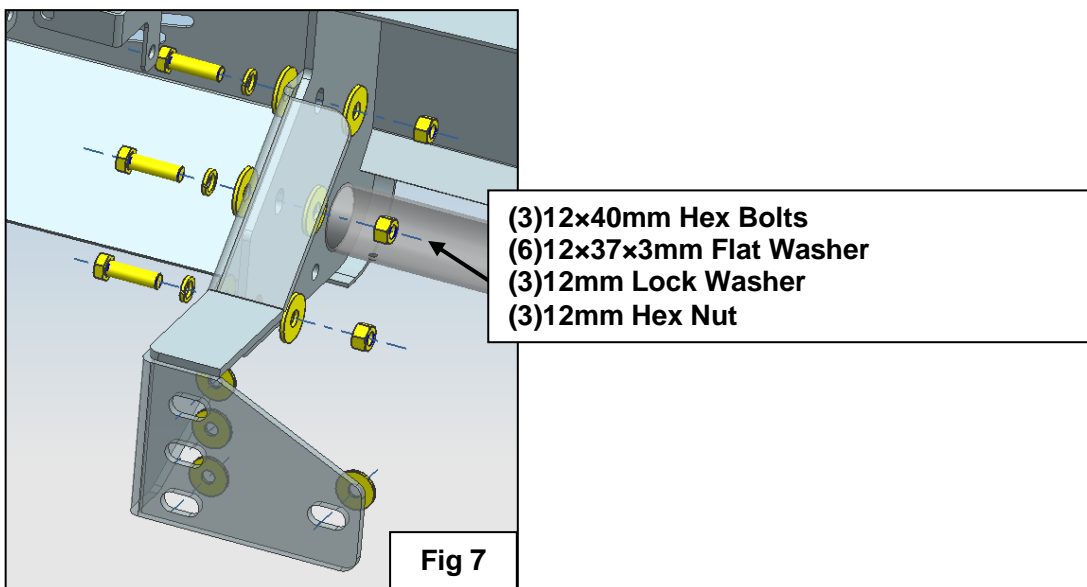

Fig 5B

2. Attach the license plate to the Replacement Bumper (Fig 6). Fasten the license plate with the hardware.



3. Fasten the Mounting Brackets to thg Bumper with the hardware (Fig 7). Do not tighten fully at this time.



4. Attach the Bumper to the frame. Fasten the Bumper with the hardware (Fig 8A & 8B).

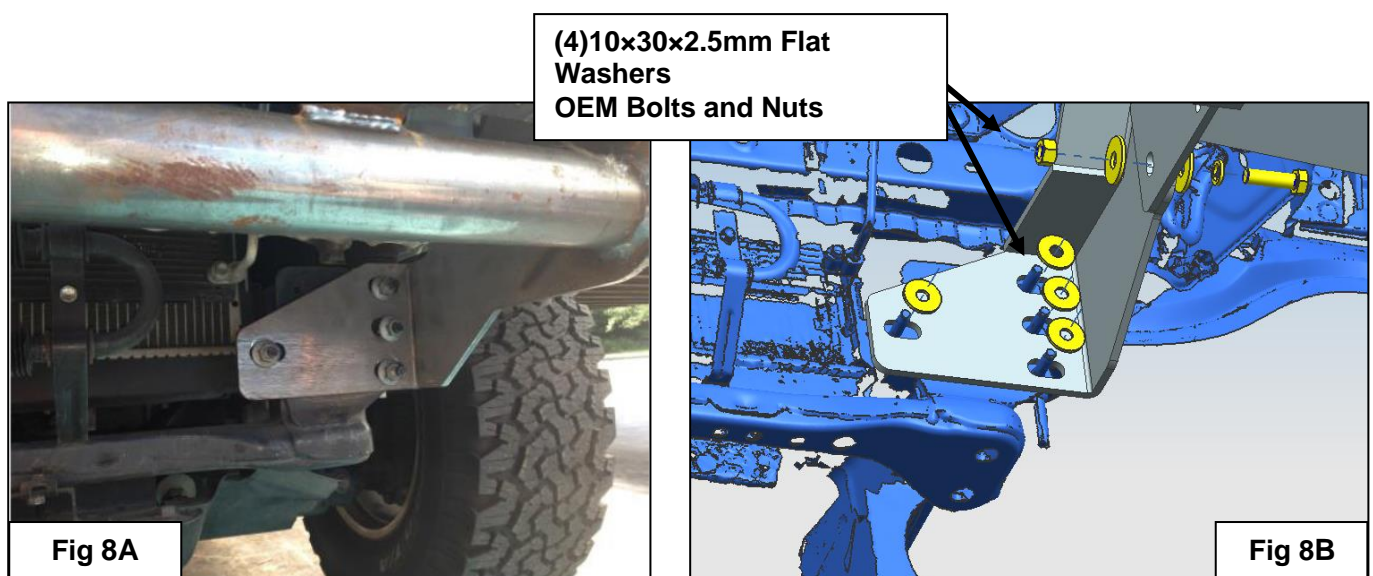

5. Reinstall the factory wiring harness to the fog light.
6. Level and adjust the bumper, make sure that all hardware is secure and tight.
7. Installation is finished, pick up all tools.

PRODUCT CARE

- Periodically check the product to ensure all fasteners are tight and components are intact.
- Regular waxing is recommended to protect the finish of the product.
- **Use ONLY Non-Abrasive automotive wax.** Use of any soap, polish or wax that contains an abrasive is detrimental and can scratch the finish leading to corrosion.
- Aluminum polish may be used to polish small scratches and scuffs for **Stainless Steel finish.**
- Mild soap may be used to clean the product for both **Stainless Steel and Black finish.**

FAQ's**1. Hardware's are not of correct size.**

In GMC / Chevrolet truck model 2006 & up, customer needs to reuse the factory body bolts to install the bracket. If your vehicle is not GMC / Chevrolet 2006 & up, ensure that holes are not partially covered with any plastic grommet or rust? If it is, remove the plastic grommet & rust from the thread holes & re-try the installation.

2. Mounting Bracket are not getting Installed properly.

In some cases Illustration images shown in Installation manual may not be the exactly same as per actual vehicle images ,also if Driver / Passenger side mounting brackets are very identical in the design, suggest referring Parts Identification guide to avoid fitment issue.

3. Products are thumping / rattling after installation.

Ensure that all required mounting brackets / hardware's are installed & tighten correctly. Suggest using white lithium / regular grease between the metal to metal contact surfaces.

4. Side Bar is not aligning with vehicle / Step Pads are not aligning with vehicle doors.

Side bar may be interchanged or mounting brackets are not installed at the correct position in the vehicle. Refer Parts identification guide.

5. Missing / Excess Hardware.

Recheck hardware count as per the part list.

6. Product not installing properly.

Ensure make model year, cab length and bed size of your vehicle is listed in the application. All installation steps are followed correctly.

Check out these other TrailFX Products!!

www.TrailFX.com



SIDE BAR



HEADACHE RACKS



RUNNING BOARDS



ROCKER GUARDS

Keystone Automotive Operations Inc. (KAO) warrants this product to be free of defects in material and workmanship at the time of purchase by the original retail consumer. KAO disclaims any other warranties, express or implied, including the warranty of fitness for a particular purpose or an intended use. If the product is found to be defective, KAO may replace or repair the product at our option, when the product is returned prepaid, with proof of purchase. Alteration to, improper installation, or misuse of this product voids the warranty. KAO's liability is limited to repair or replacement of products found to be defective, and specifically excludes liability for any incidental or consequential loss or damage.