

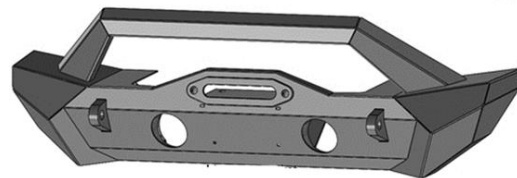

FRONT BUMPER

Part No. JL08T



Fits: 2018 JEEP Wrangler JL(Incl. 2020 diesel engine)



REMOVE CONTENTS FROM BOX. VERIFY ALL PARTS ARE PRESENT.



READ INSTRUCTIONS CAREFULLY BEFORE STARTING INSTALLATION.

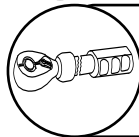

DO NOT OVER TORQUE. STANDARD OPERATING LOAD FOR TIGHTENING BODY MOUNT NUTS & BOLTS VARIES FROM 7 TO 8.5 FOOT POUND FOR M6, 18 TO 20 FOOT POUND FOR M8 AND, 60 TO 70 FOOT POUND FOR M12



60-180 min

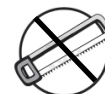

Cutting Not Required



Drilling Not Required



support@trailfx.com



1 866 638 4870



POLISHED STAINLESS STEEL – LIMITED LIFETIME
POWDER COATED BLACK – 3 YEARS

PARTS LIST:

PARTS LIST:

Qty	Part Description	Qty	Part Description
1	TFX Front Bumper	14	8mm Lock Washers
1	TFX Skid Plate	2	8mm x 20mm Hex Bolts
1	Driver/left Skid Plate Bracket	22	8mm x 24mm x 2mm Flat Washers
1	Passenger/right Skid Plate Bracket	2	8mm x 25mm Hex Nuts
2	LED Light Brackets	8	8mm x 25mm Button Bolts
2	Fog Light Adapter Brackets	2	8mm x 40mm x 40mm Plastic Retainers
1	License Plate Bracket	2	6mm Nylon Lock Nuts
2	Plastic Plugs for License Plate	4	6mm x 18mm x 1.6mm Flat Washers
4	12mm x 35mm Bolt and Nut Plates	2	6mm x 20mm Button Bolts
4	12mm Hex Nuts	8	4mm Hex Nuts
8	12mm Lock Washers	12	4mm Lock Washers
4	12mm x 35 Hex Bolts	20	4mm x 12mm x 1.0mm Flat Washers
8	12mm x 37mm x 3mm Large Flat Washers	12	4mm x 15mm Button Bolt
4	12mm x 40mm x 40mm Plastic Retainers	1	4mm Allen Wrench
2	8mm x 25mm Bolt and Nut Plates	1	6mm Allen Wrench
10	8mm Hex Nuts	1	8mm Allen Wrench

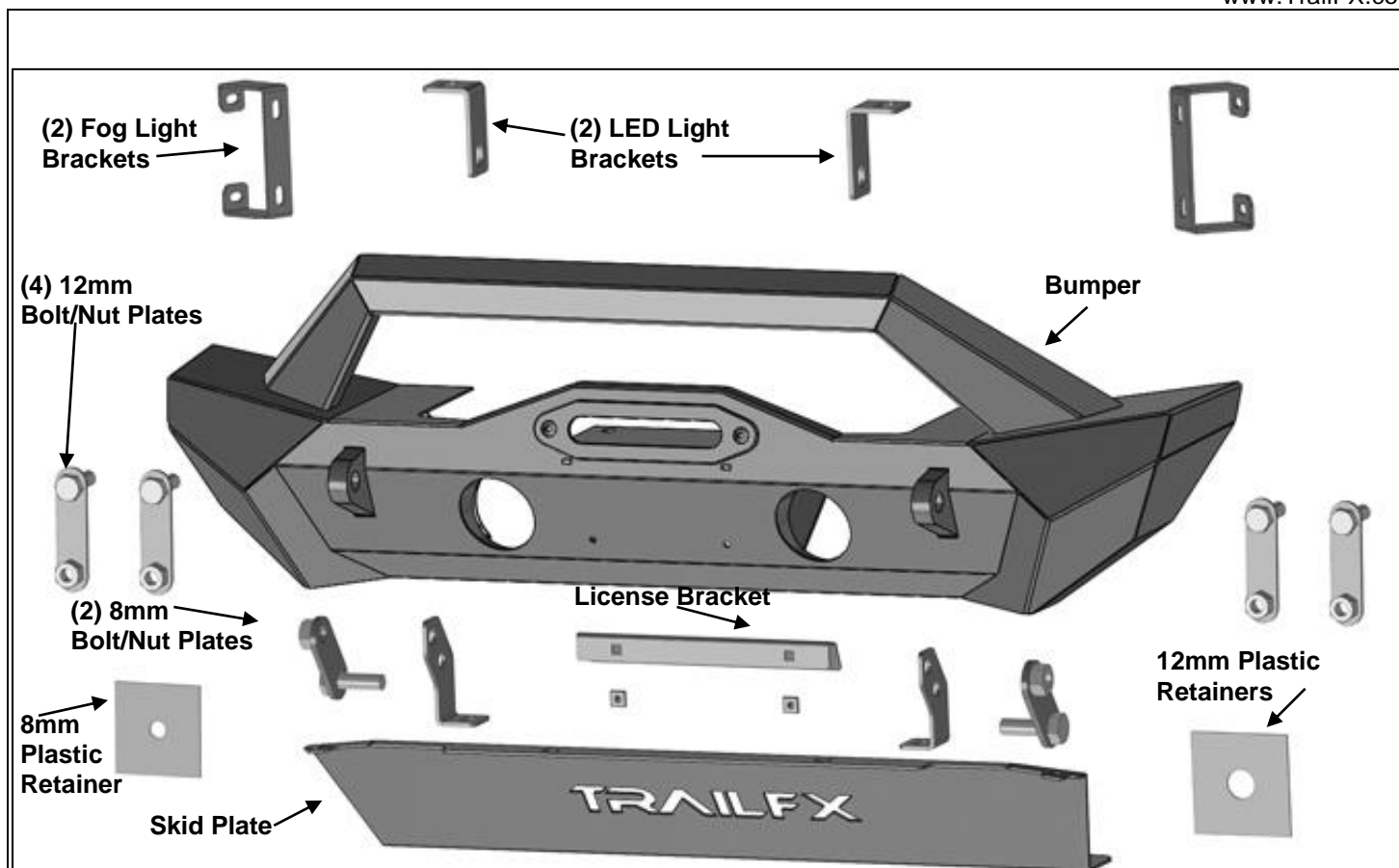
**PROCEDURE:**

REMOVE CONTENTS FROM BOX. VERIFY ALL PARTS ARE PRESENT. READ INSTRUCTIONS CAREFULLY BEFORE STARTING INSTALLATION. ASSISTANCE IS RECOMMENDED.

1. Start under the front bumper of the vehicle, remove the plastic lower splash guard or skid plate, **(Figure 1)**.
2. With assistance, remove the front bumper hardware and bumper, **(Figures 1 & 2)**. Move the factory bumper to a stable surface. Remove steel bracket for the plastic splash guard, (if equipped), attached to the front of the frame.
3. On models with factory fog lights, unscrew bolts securing the fog lights.
4. Place the TFX Front Bumper on a stable clean flat surface. Select (2) 12mm Nut/Bolt Plates and (2) 12mm Plastic Retainers. Insert the Nut/Bolt plates behind the mounting plate on the back of the Bumper, **(Figure 3)**. Thread the Plastic Retainers tight against the Nut/Bolt Plates to hold in place during Bumper installation. Repeat Step for the other side of the Bumper.
5. With assistance, hold the Bumper Assembly up to the frame and align the Nut/Bolt Plates to the mounting holes on the frame. Use (8) 12mm Flat Washers, (8) 12mm Lock Washers, (4) 12mm Hex Nuts and (4) 12mm Hex Bolts (to attach the Nut/Bolt Plates to the Bumper, **(Figures 5—7)**). Do not fully tighten hardware at this time.
6. **Determine fog light installation:**
 - 4-bolt, evenly spaced mounting style (Excludes 2-bolt LED and halogen fog lights as supplied with models with OE steel winch compatible option bumper)**
 - a. Select (1) Adapter Bracket, **(Figure 8)**. Attach the Adapter Bracket to the inner mounting location with (2) 4mm Button Head Bolts, (2) 4mm Lock Washers and (2) 4mm Flat Washers, **(Figure 8)**.
 - b. Attach the Driver/Left fog light assembly to the outer mounting plate and the inner Adapter Bracket with (4) 4mm Button Head Bolts, (8) 4mm Flat Washers (4) 4mm Lock Washers and (4) 4mm Hex Nuts, **(Figures 9 & 10)**. **IMPORTANT:** Do not overtighten fog light hardware or damage to the fog light may result.
 - Sport model w-1pc plastic bumper. Offset mounting style (1 Bolt to outside, 2 Bolts to inside of housing)**
 - a. Select the Driver/Left fog light assembly.
 - b. Attach the outer single tab on the light housing to the mounting plate with (1) 4mm Button Head Bolt, (2) 4mm Flat Washers, (1) 4mm Lock Washer and (1) 4mm Hex Nut. Leave hardware loose at this time.
 - c. Attach the inner side of the housing to the inner mounting plate with (3) 4mm Button Head Bolts, (3) 4mm Lock Washers and (3) 4mm Flat Washers. Tighten fog light mounting hardware. **IMPORTANT:** Do not overtighten fog light hardware or damage to the fog light may result.
7. **LED light bar installation, (LED light bar sold separately).**
 - a. Select (2) LED Light Brackets. Attach the Brackets to the top of the mounting tab on the back of the hoop of the Bumper with the included (2) 8mm x 25mm Hex Bolts, (4) 8mm Flat Washers, (2) 8mm

Lock Washers and (2) 8mm Hex Nuts, **(Figure 12)**. Leave hardware loose. **NOTE:** "L" Brackets are designed for 8mm light mounting hardware only. Modify "L" Brackets if necessary, to install hardware larger than 8mm.

- b. Next, attach the light bar, (not included), to the Brackets with the included (2) 8mm x 20mm Button Head Bolts, (2) 8mm Lock Washers and (2) 8mm Flat Washers, **(Figure 13)**. Do not fully tighten hardware at this time.

8. Winch Installation, (winch not included).

- a. Attach the winch to the top of the mounting plate behind the Bumper, **(Figure 14)**.
- b. Follow the manufacturer's instructions to properly attach the winch to the top of the bumper and to connect the winch to the electrical system. **NOTE:** As per winch instructions, never wind rope over top of the winch drum.

9. Select the License Plate Bracket. Attach the Bracket to the bottom of the bumper using (2) 6mm Button Bolts, (4) 6mm Flat Washers and (2) 6mm Nylon Lock Nuts, **(Figure 15)**. Use the provided (2) Plastic Plugs to attach the License Plate to the front of the Bracket, **(Figure 16)**.

10. Select the Passenger/Right Skid Plate Bracket:

- a. Locate hexagonal hole in the passenger/right frame, **(Figures 17 & 18)**.
- b. Insert (1) 8mm Bolt Plate through the bottom of the frame opening, through the hexagonal hole. Secure the Bracket to the frame using (2) 8mm Flat Washer, (2) 8mm Lock Washer (1) 8mm Hex Nut and (1) 8mm Button Head Bolt, **(Figure 19)**.

11. Stand back from the vehicle and check to see that the Bumper is centered and level on the vehicle and adjust as required. Once properly aligned, fully tighten all hardware.

12. Next, select the Skid Plate. Attach the Skid Plate to the back of the Bumper using (4) 8mm Button Head Bolts, (8) 8mm Flat Washers, (4) 8mm Lock Washers and (4) 8mm Hex Nuts, **(Figure 20)**. Do not tighten hardware. Repeat **Steps 10 and 11** for the Driver/Left Skid Plate Bracket installation.

13. Attach the other end of the Skid Plate Bracket to the Skid Plate Brackets with (2) 8mm x 30mm Button Head Bolts, (4) 8mm Flat Washers, (2) 8mm Lock Washers and (2) 8mm Hex Nuts, **(Figure 20)**. Leave hardware loose. Adjust the Skid Plate as necessary and tighten skid plate hardware.

14. Do periodic inspections of the installation to make sure that all hardware is secure and tight.

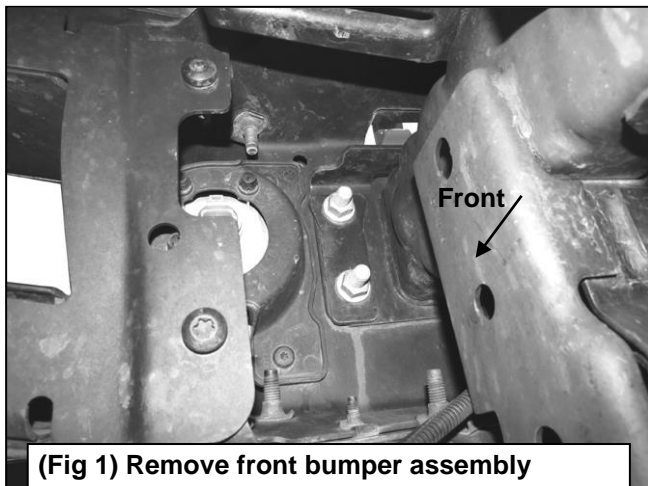

(Fig 1) Remove front bumper assembly (driver side outer bumper bolts pictured)



(Fig 2) Front Bumper and splash guard removed

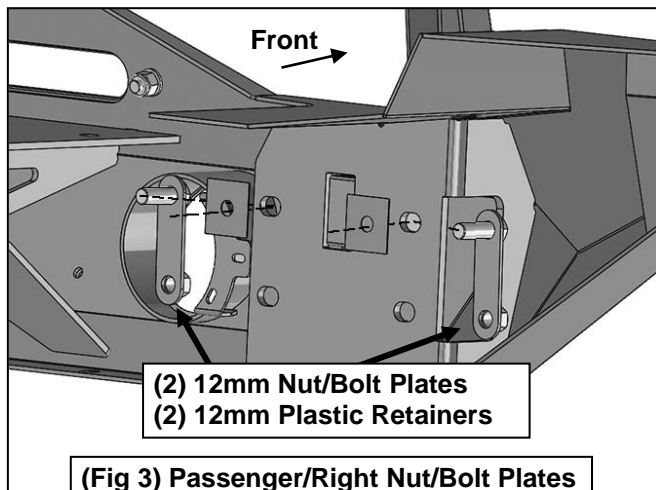

(Fig 3) Passenger/Right Nut/Bolt Plates with Plastic Retainers installed

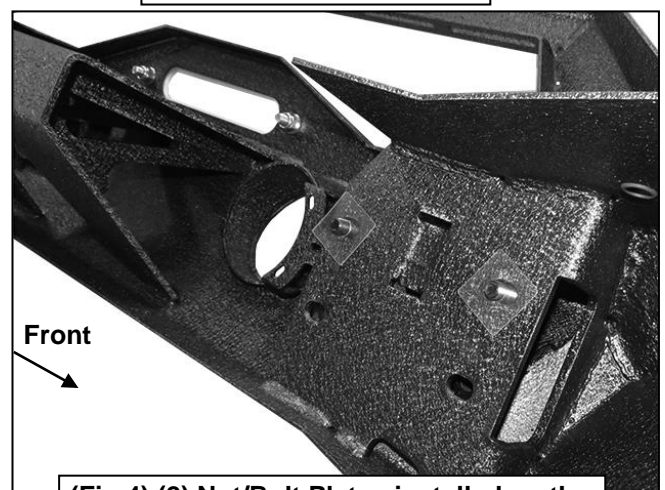

(Fig 4) (2) Nut/Bolt Plates installed on the Passenger/Right back of the Bumper

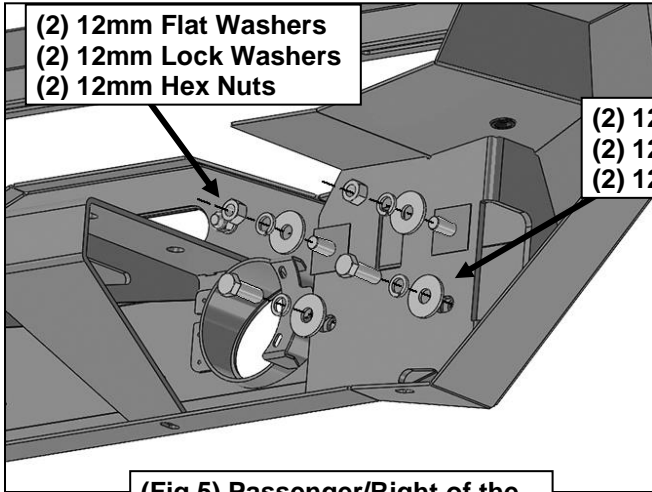

(Fig 5) Passenger/Right of the Bumper attached to the frame

- (2) 12mm Flat Washers
- (2) 12mm Lock Washers
- (2) 12mm Hex Bolts

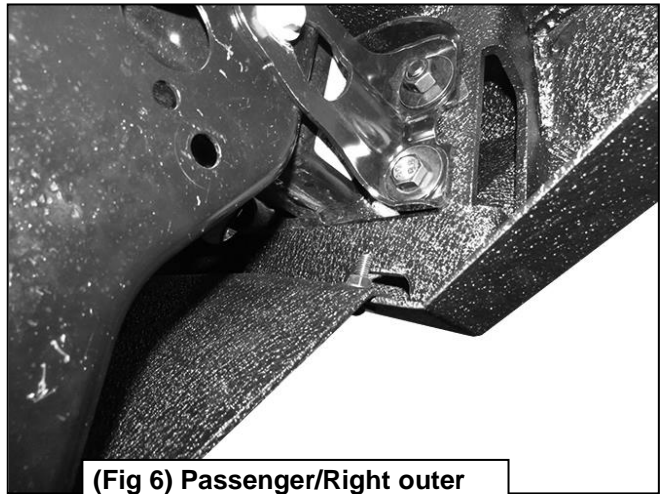

(Fig 6) Passenger/Right outer Bumper attached to the frame

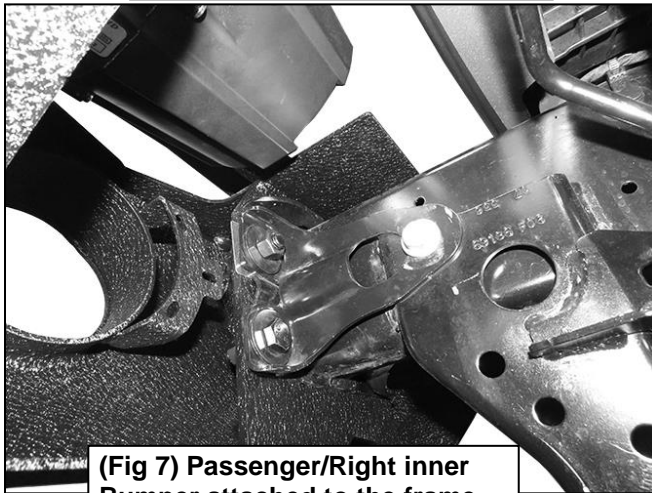

(Fig 7) Passenger/Right inner Bumper attached to the frame

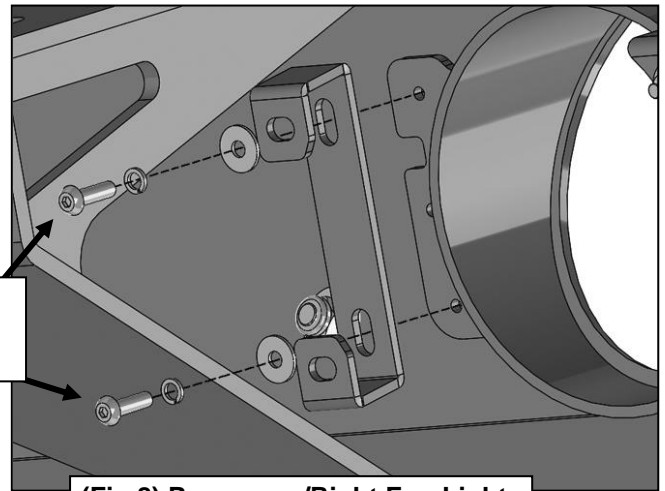

(Fig 8) Passenger/Right Fog Light Adapter Bracket Installation

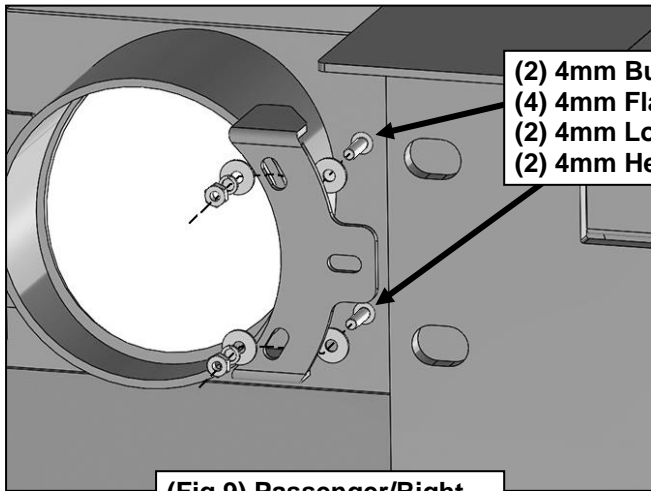

(Fig 9) Passenger/Right Fog Light Installation

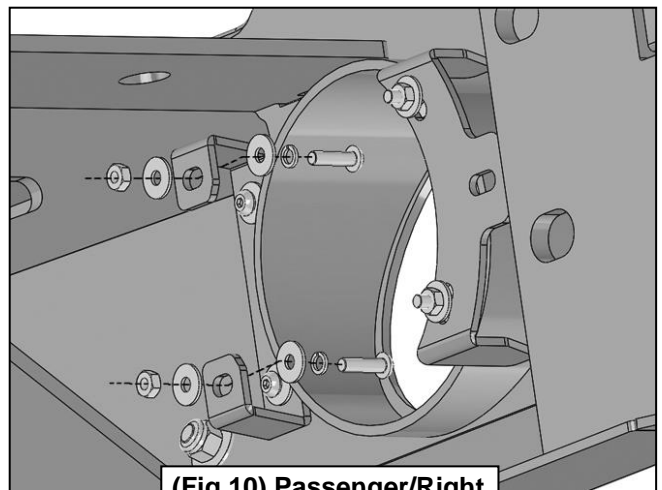

(Fig 10) Passenger/Right Fog Light Installation



(Fig 11) Passenger/Right Fog Light with Adapter Bracket installed

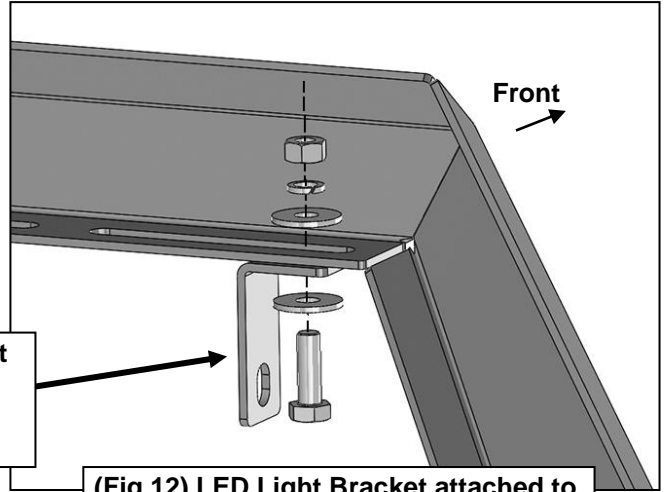

- 8mm x 25mm Hex Bolt
- (2) 8mm Flat Washers
- 8mm Lock Washer
- 8mm Hex Nut

(Fig 12) LED Light Bracket attached to the top mounting tab of the Bumper

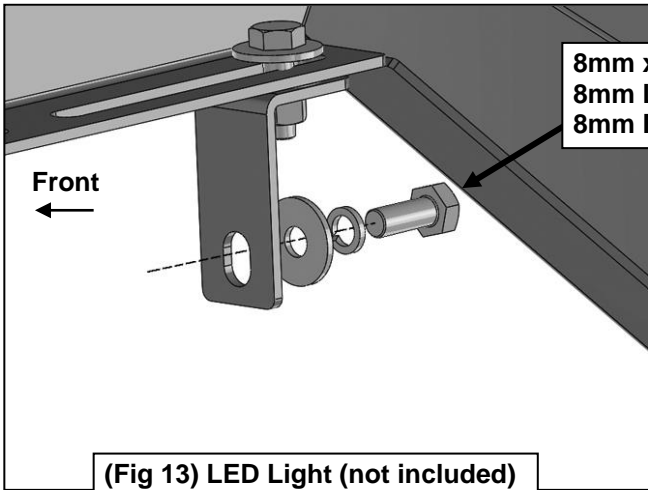

- 8mm x 20mm Hex Bolt
- 8mm Lock Washer
- 8mm Flat Washer

(Fig 13) LED Light (not included) attached to Light Brackets

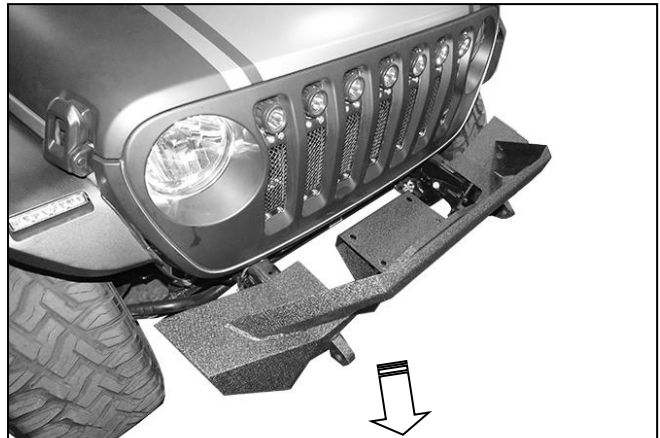

(Fig 14) Attach winch (not included) to the mounting plate on the back of the Bumper

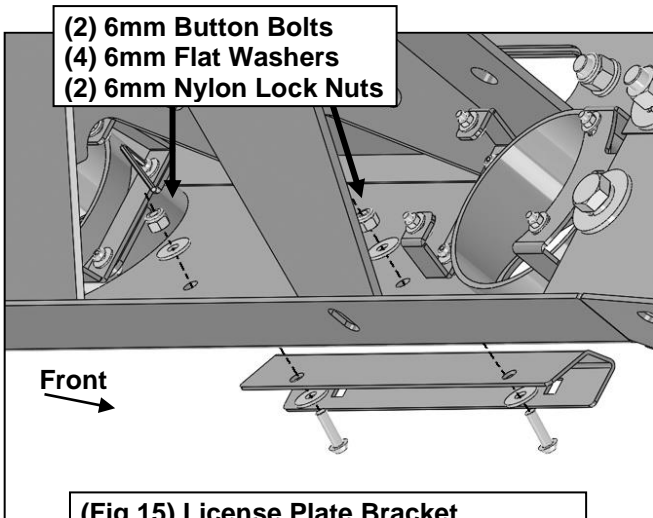

- (2) 6mm Button Bolts
- (4) 6mm Flat Washers
- (2) 6mm Nylon Lock Nuts

(Fig 15) License Plate Bracket attached to the Front of the Bumper

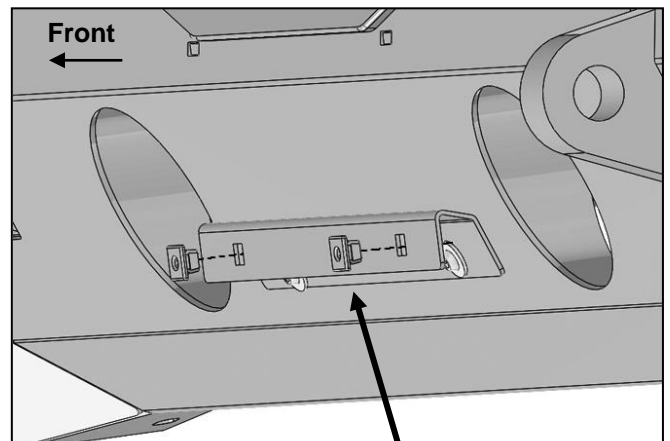

(Fig 16) Attach License Plate using the provided (2) Plastic Plugs

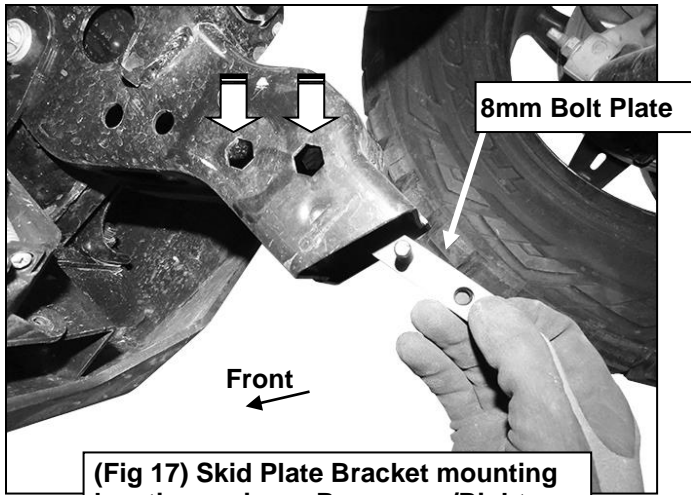

(Fig 17) Skid Plate Bracket mounting location on inner Passenger/Right

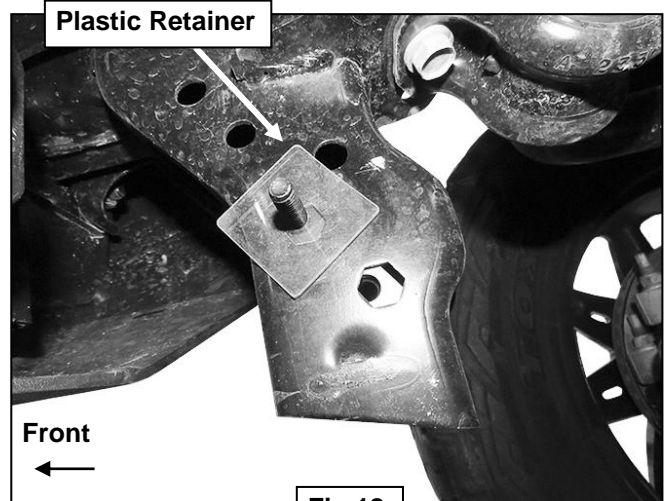
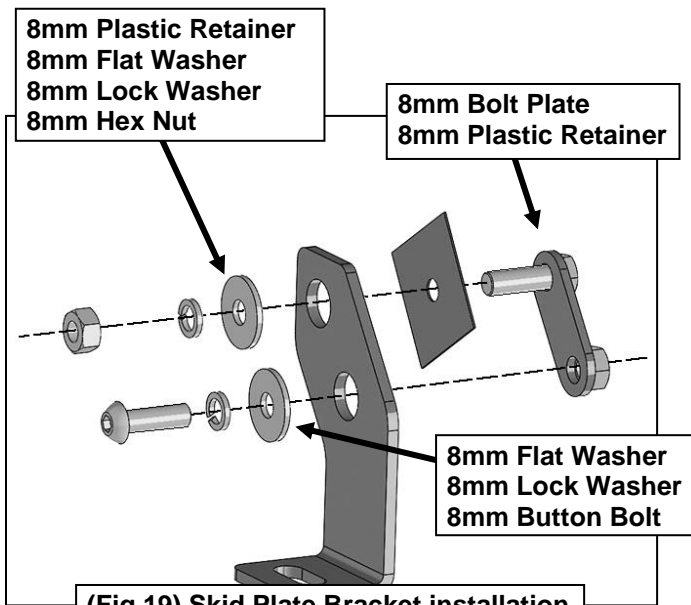
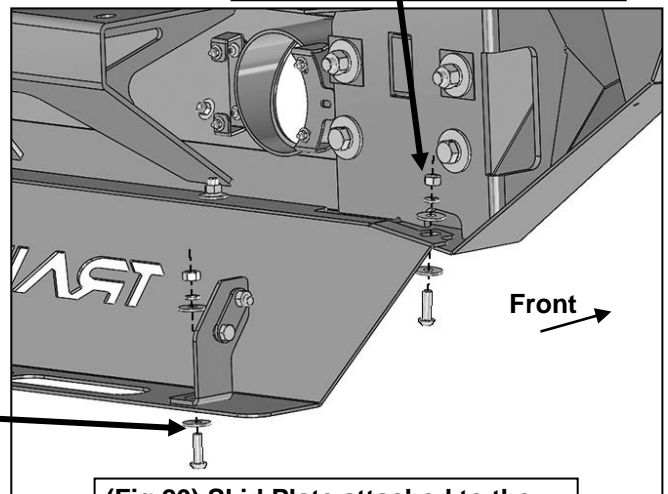

Fig 18



(Fig 19) Skid Plate Bracket installation

- (4) 8mm Button Bolt
- (8) 8mm Flat Washer
- (4) 8mm Lock Washer
- (4) 8mm Hex Nut



(Fig 20) Skid Plate attached to the bottom of the Bumper

- 8mm x 30mm Button Bolt
- (2) 8mm Flat Washers
- 8mm Lock Washer
- 8mm Hex Nut

PRODUCT CARE

- Periodically check the product to ensure all fasteners are tight and components are intact.
- Regular waxing is recommended to protect the finish of the product.
- **Use ONLY Non-Abrasive automotive wax.** Use of any soap, polish or wax that contains an abrasive is detrimental and can scratch the finish leading to corrosion.
- Aluminum polish may be used to polish small scratches and scuffs for **Stainless Steel finish.**
- Mild soap may be used to clean the product for both **Stainless Steel and Black finish.**

FAQ's**1. Hardware's are not of correct size.**

In GMC / Chevrolet truck model 2006 & up, customer needs to reuse the factory body bolts to install the bracket. If your vehicle is not GMC / Chevrolet 2006 & up, ensure that holes are not partially covered with any plastic grommet or rust? If it is, remove the plastic grommet & rust from the thread holes & re-try the installation.

2. Mounting Bracket are not getting Installed properly.

In some cases Illustration images shown in Installation manual may not be the exactly same as per actual vehicle images ,also if Driver / Passenger side mounting brackets are very identical in the design, suggest referring Parts Identification guide to avoid fitment issue.

3. Products are thumping / rattling after installation.

Ensure that all required mounting brackets / hardware's are installed & tighten correctly. Suggest using white lithium / regular grease between the metal to metal contact surfaces.

4. Side Bar is not aligning with vehicle / Step Pads are not aligning with vehicle doors.

Side bar may be interchanged or mounting brackets are not installed at the correct position in the vehicle. Refer Parts identification guide.

5. Missing / Excess Hardware.

Recheck hardware count as per the part list.

6. Product not installing properly.

Ensure make model year, cab length and bed size of your vehicle is listed in the application. All installation steps are followed correctly.

Check out these other TrailFX Products!!

www.TrailFX.com



BULL BAR



GRILLE GUARDS



BED RAILS



RUNNING BOARDS

Keystone Automotive Operations Inc. (KAO) warrants this product to be free of defects in material and workmanship at the time of purchase by the original retail consumer. KAO disclaims any other warranties, express or implied, including the warranty of fitness for a particular purpose or an intended use. If the product is found to be defective, KAO may replace or repair the product at our option, when the product is returned prepaid, with proof of purchase. Alteration to, improper installation, or misuse of this product voids the warranty. KAO's liability is limited to repair or replacement of products found to be defective, and specifically excludes liability for any incidental or consequential loss or damage.