

IMPORTANT NOTICE: Be sure to inspect and test fit product before having it coated or painted. Ranch Hand will not be responsible for the cost of the coating if any problems with fit or finish are not noted and addressed beforehand.

TOOLS REQUIRED

- Ratchet & Extension
- 7/16", 1/2", 5/8", 11/16" & 3/4" sockets & wrenches
- 8mm & 18mm sockets & wrenches
- 5/32" Allen wrench
- Plastic pry tool
- Snips
- Zip-ties

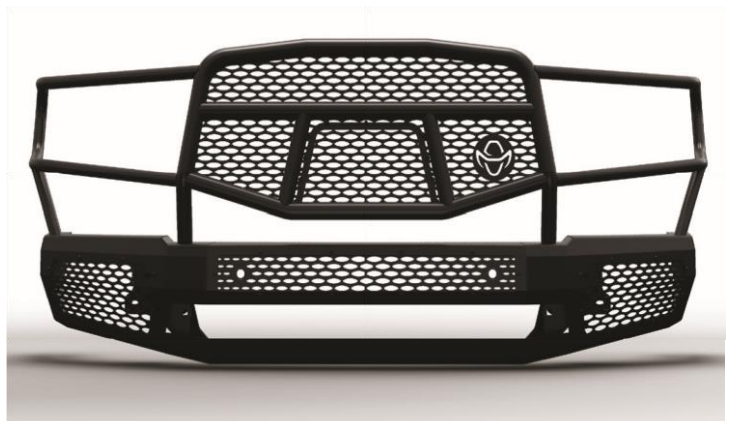

Please read through the entire set of instructions before continuing with installation to familiarize yourself with the process, save time, and make sure that you have all the correct tools and parts needed to complete this installation. More detailed instructions can be found on our website.

DISASSEMBLY INSTRUCTIONS

1. With an 8mm socket, remove the five (5) bolts located under both the passenger side and driver side wheel wells. Once the bolts have been removed, remove the plastic wheel well cover from the vehicle.
2. Find the harness plug on the driver side of the vehicle. Disconnect it.
3. Use an 18mm socket to remove the three (3) nuts from both the driver and passenger frame rails to disconnect the bumper from the truck.
4. Then remove the bumper from the truck.
5. Remove the OEM electrical harness from bumper by removing the push pins.
6. Disconnect the electrical harness from the fog lights in the bumper.
7. Remove the six (6) sensors from the sensor housing. To accomplish this, expand both sides of the sensor housing and lift or push up.

PREPPING THE MIDNIGHT FRONT BUMPER FOR INSTALLATION

To prepare for installation, begin by laying out the included components in the box. Each part required for installation is wrapped individually and should be accounted for along with the included checklist. Please inspect all parts of your new Ranch Hand product before installing. If any parts are missing or damaged, please contact the Ranch Hand Customer Service Team, customerservice@ranchhand.com, immediately before proceeding with installation.

1. Begin by taking the bumper out of the box and position the bumper on the ground, just as it would sit on your truck/SUV.
2. Locate the passenger and driver side fog light inserts and fog light brackets. *Note: These must be installed at the same time as they share two of the provided bolts, washers, and bolt locations.
3. Place the fog light insert through the back of the bumper. Using a 5/32" Allen wrench, Allen key, or hex key and 7/16" wrench secure the two bottom and two outer edge holes with the provided 1/4" socket button head bolts and Kep nut.
4. Place the fog light bracket in position over the fog light insert. Secure both the fog light inserts and bracket to the bumper using the 1/4" socket button head bolts and Kep nuts (8x per side).
5. Repeat this step for both the passenger and driver side of the bumper.
6. Place the center fog light insert, from the inside, in the middle of the bumper and begin securing the 1/4" socket button head bolts and Kep nuts. Secure eight of the holes, leaving the center bottom two holes as is without bolts. These will be used to attach the license plate later.
7. Place the removable camera insert on the grille guard from the inside and attach with the 1/4" socket button head bolts and Kep nuts.
*Note: If your vehicle comes equipped with a front mounted camera, skip this step.

FOR VEHICLES WITH SENSORS

NOTE: TRY USING THE SMALL GROMMET WITH YOUR SENSORS FIRST. IF THE SENSOR WILL NOT FIT OR IS TOO TIGHT, REMOVE THE “KNOCK-OUT” SECTION AND USE THE LARGER GROMMET.

1. If your vehicle has OEM front parking sensors, carefully remove the sensors from the OEM bumper.
2. Carefully knockout the sensor holes located on the fog inserts so the proper diameter sensor hole is achieved. Do this for the two knockouts located on the bumper as well. If your bumper did not include knockouts on the bumper body, drill the sensor holes (1.25-inch Diameter) per the provided sensor location drawing.
3. Using the grommets provided in the included bolt pack, reinstall the OEM sensors. Place the grommet inside the hole directly on the insert. Once it is in place, apply WD-40 around the inside of the grommet to help guide the sensor into place without damaging it. Push the sensor through the grommet from the back side of the insert.
4. Take the sensor pigtail/wires that were removed from the OEM bumper and route the wiring harness from sensor to sensor on the bumper. Route the wires through the mounting bracket using the holes located on the sides of both brackets. Be sure to avoid leaving the wiring harness on top of the bracket.
5. If using the OEM fog lights, use the provided OEM fog light mounting bracket (specific to your vehicle) and bolt it directly into the light pod mount.
6. All aftermarket products that you plan to attach to the bumper, including lightbars, should be installed at this time for ease of installation.

INSTALLING THE MIDNIGHT FRONT BUMPER

Refer to the provided schematic diagram that indicates proper placement of bolts and their locations. The following steps are recommended to be performed with at least one partner; we recommend having two partners to assist. One to help hold the bumper in place and the other to guide the bolts through the brackets and into the frame.

1. With one person supporting each side, line the bumper’s mounting plate up with the mounting bracket. A third person should be underneath the vehicle to temporarily tighten each of the bolts to secure the bumper to the mounting bracket per mounting diagram.
2. With two people still supporting each side of the bumper, adjust the bumper so that there is an even amount of space along the grille, the headlights, and all the way across the front of the truck. Once the bumper is in place, continue by tightening all the mounting hardware.
3. Reconnect any OEM wiring harnesses disconnected when removing the OEM bumper. This includes fog light wiring harnesses or sensor wiring harnesses. All must be plugged back into OEM location on truck. It may be necessary to use zip ties to secure loose wiring.

ADA INSTALLATION

1. See packing list to identify ADA for installation.
2. Have one person hold the ADA bar in place while the other places bolts through the bolt holes and hand tighten the nuts (very similar to step 1 above titled, “Installing the Midnight Front Bumper). DO NOT over-tighten the bolts, otherwise step 2 will become difficult.
3. Adjust the placement of the ADA until it is flush and aligned with the rest of the bumper. Once in place, firmly tighten the bolts.

Note: If installing a winch tray (packaged/sold separately), do not install the ADA bar and please refer to the winch installation instructions at this time.

LICENSE PLATE BRACKET INSTALLATION

1. Retrieve the U-shaped license plate bracket as well as the four ¼” socket button head bolts and Kep nuts.
2. Attach the top of the U-bracket to the grille guard using the two ¼” socket button head bolts and Kep nuts.
3. Attach the license plate to the bottom of the U-bracket using the two ¼” socket button head bolts and Kep nuts bolts.
4. Check and tighten all mounting fasteners.

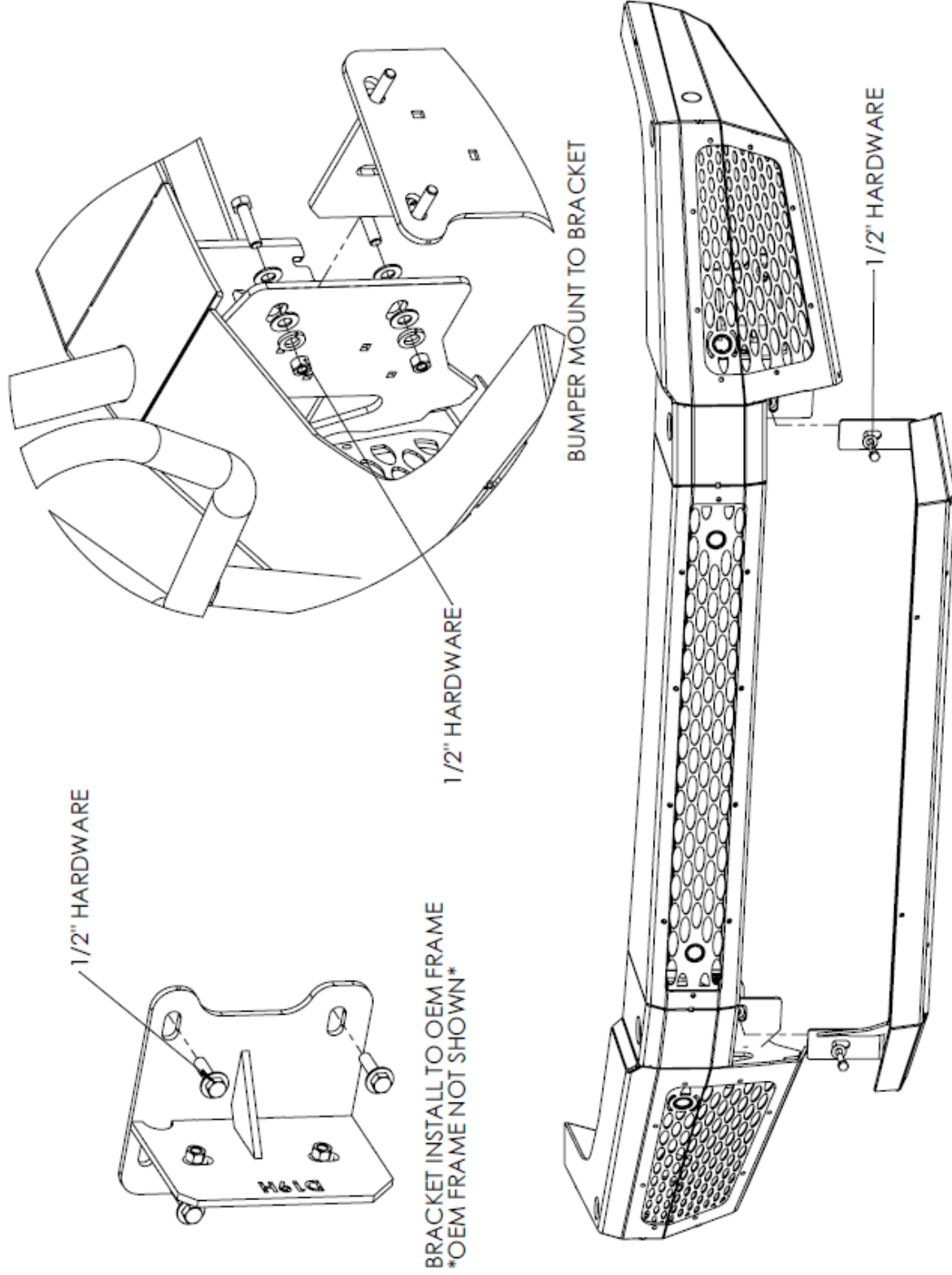

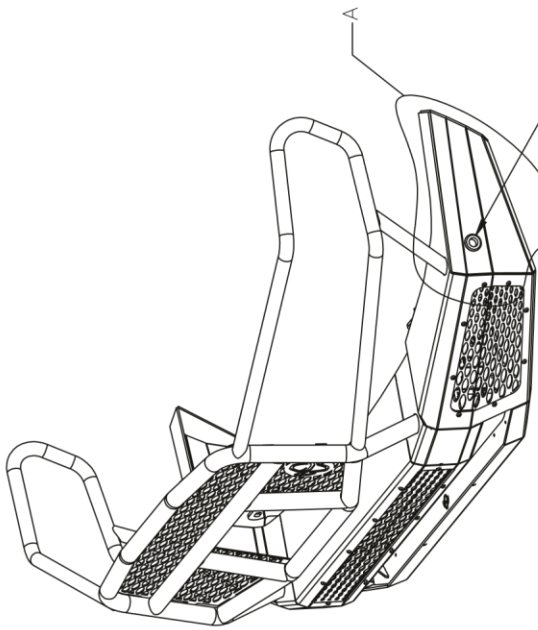

INSTALLATION LOCATION
OPTIONAL 6 SENSOR PARKING
SYSTEM
DRIVER SIDE SHOWN

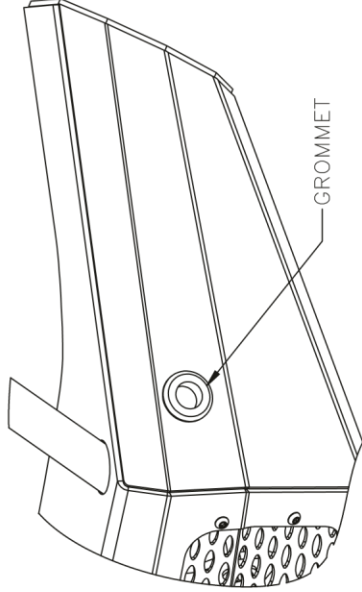

DETAIL A
INSTALL LOCATION

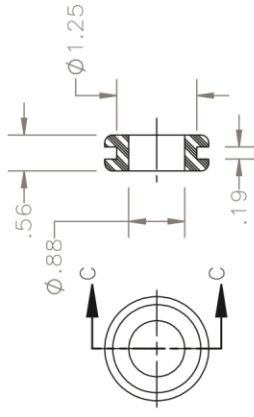

SECTION C-C
SCALE 1 : 2

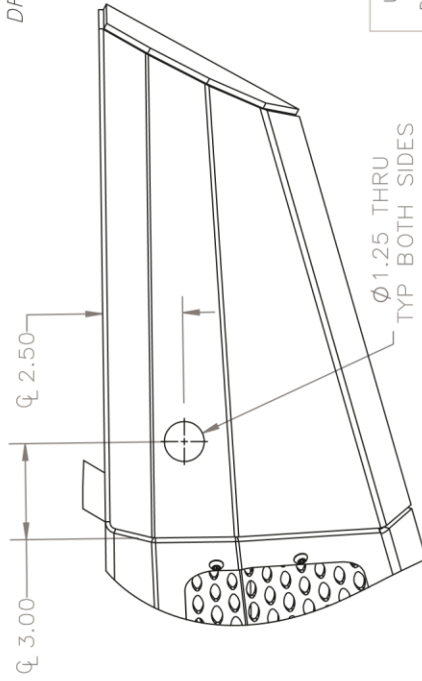

DETAIL B
DRILL LOCATION
TYP BOTH SIDES
DRIVER SIDE SHOWN

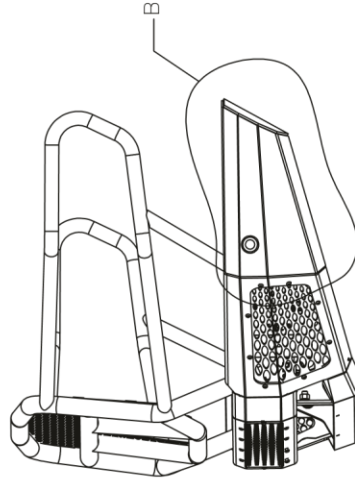

		9519 State Hwy 95 N Shiner, TX 77984 Phone: 1-800-366-9712	
UNLESS OTHERWISE SPECIFIED: DIMENSIONS ARE IN INCHES TOLERANCES PER ASME Y14.5M ANGULAR: MACH ± .5° BEND ± 1° TWO PLACE DECIMAL ± .06 THREE PLACE DECIMAL ± .03 PROPRIETARY AND CONFIDENTIAL THE INFORMATION CONTAINED IN THIS DRAWING IS THE SOLE PROPERTY OF KASPAR RANCH HAND. ANY REPRODUCTION IN PART OR AS A WHOLE WITHOUT THE WRITTEN PERMISSION OF KASPAR RANCH HAND IS PROHIBITED.	DRAWN CHECKED ENG APPR.	NAME BJK BJK BJK	DATE 11/19/2018 05/04/2020 05/04/2020
TITLE ADDITIONAL SENSOR LOCATION RAM 1500 6 SENSOR PACKAGE		SIZE B NO DWG NO MFD19HNBL1	REV A01
MATERIAL WEIGHT (LBS.)		See BOM 183.46	DO NOT SCALE DRAWING SHEET 1 OF 1