

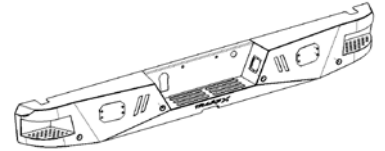

# Rear LD Bumper

Part No. RLDB001TI



Fits: **2015-Current Ford F150**



OEM "HD" receiver hitch integrated into factory rear bumper cannot be reinstalled



REMOVE CONTENTS FROM BOX. VERIFY ALL PARTS ARE PRESENT.



READ INSTRUCTIONS CAREFULLY BEFORE STARTING INSTALLATION.

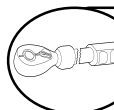

DO NOT OVER TORQUE. STANDARD OPERATING LOAD FOR TIGHTEN BODY MOUNT NUTS & BOLTS VARIES FROM **45 TO 65** FOOT POUND.



60-180 min

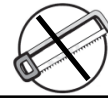

Cutting Not Required



Drilling Not Required



[support@trailfx.com](mailto:support@trailfx.com)



1 866 638 4870



**POLISHED STAINLESS STEEL – LIMITED LIFETIME**  
**POWDER COATED BLACK – 3 YEARS**

### PARTS LIST:

Qty	Part Description	Qty	Part Description
1	Rear Bumper Assembly	8	4mm x 10mm Button Head Bolts
2	Mounting Brackets	1	4mm Wrench
4	Sensor Hole Plugs	1	6mm Wrench
2	Plastic Plugs for license plate mount	10	Nylon Wire Ties
6	12-1.75mm x 50mm Hex Bolts	4	15.5mm x 25mm x 2mm Foam Washers
4	12-1.75mm x 35mm Hex Bolts	4	20mm x 10mm Foam Spacers
16	12mm x 37mm x 3mm Flat Washers	4	Retaining Rings
4	12mm Lock Washers	1	Sensor Covers Kit
6	12 mm Nylon Lock Nuts		

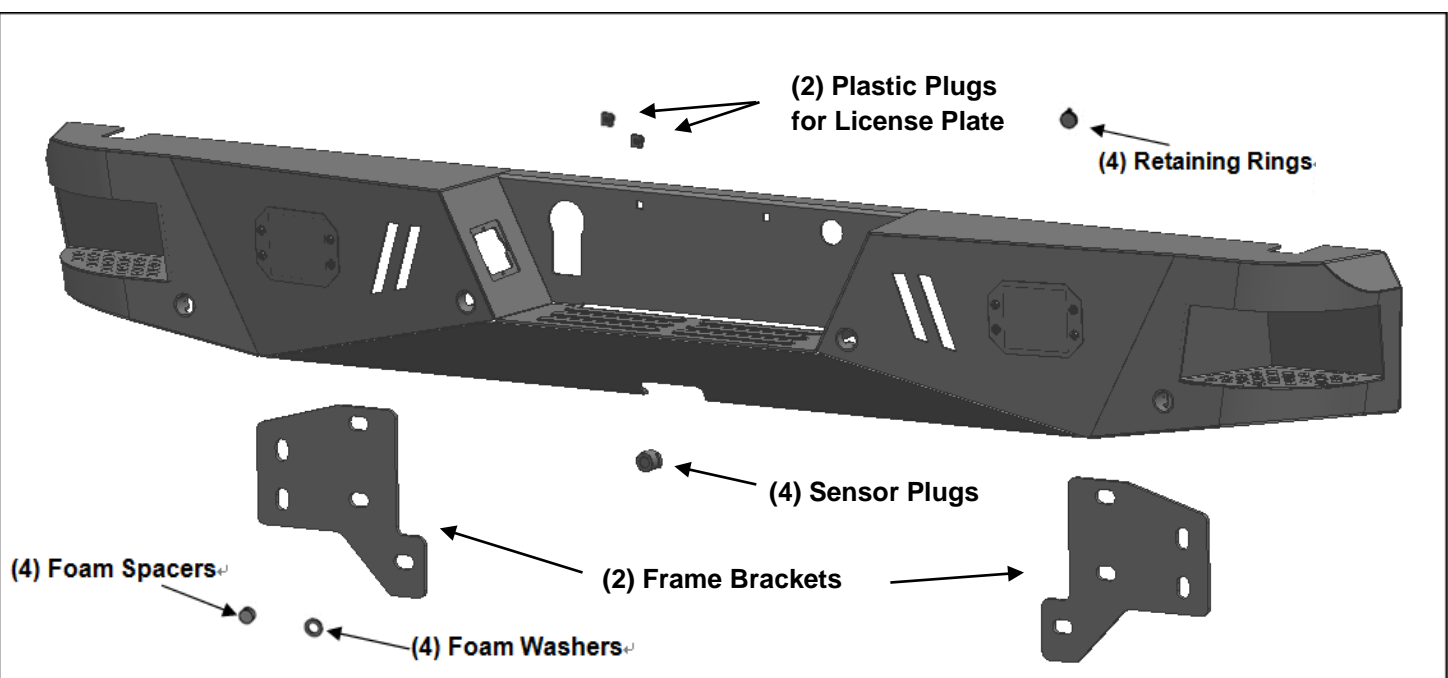

**INSTALLATION PROCEDURE:**

**ASSISTANCE IS RECOMMENDED TO AVOID POSSIBLE INJURY OR DAMAGE TO THE VEHICLE.**

**IMPORTANT: OEM "HD" RECEIVER HITCH INTEGRATED INTO FACTORY REAR BUMPER CANNOT BE REINSTALLED. INSTALLATION IS COMPATIBLE WITH OEM "MAX DUTY" HITCH AND MOST AFTERMARKET RECEIVER HITCHES.**

1. Remove the license plate from the bumper, **(Figure 1)**. Next, unplug the license plate lights, trailer plug and sensors, (if equipped). Release the wiring harness from the clips attached to the back of the bumper. Move all wiring harnesses away from bumper. **NOTE:** Bumper is designed to be compatible with larger 7-wire universal trailer harness plug.
2. Next, release the clips holding the license plate lights in place and remove the lights, **(Figure 2)**. Release the clips securing the trailer plug and remove the plug.
3. Place blocks or jack stands under the bumper to support it during mounting bolt removal. Once the bumper has been safely supported, remove the factory hardware attaching the bumper to the end of the frame and remove the bumper, **(Figures 3A, 3B & 4)**. **WARNING!** Assistance is required to hold the bumper in place during hardware removal to prevent bumper from falling.  
**IMPORTANT:** On models with FORD "HD" tow package, the factory bumper features an integrated receiver hitch and it cannot be reinstalled with the replacement Bumper, **(Figure 3A)**. Bumper is compatible with models without receiver hitch, (standard tow package-**Figure 3B**), and with the FORD "MAX DUTY" tow package, (separate receiver hitch). Bumper is also compatible with most replacement receiver hitches.
4. Select (1) Mounting Bracket, **(Figure 5A)**. Attach the Bracket to the passenger side mounting plate on the back of the bumper with the included (2) 12mm x 35mm Hex Bolts, (2) 12mm Lock Washers and (2) 12mm Flat Washers, **(Figures 5A & 5B)**. Snug but do not fully tighten at this time. Repeat this **Step** to attach the Mounting Bracket on the driver side.
5. **NOTE:** Sensors, (if equipped), must be installed onto the back of the Bumper before installing the Bumper to the vehicle.  
**Models without bumper sensors:**
  - a. Select the included (4) Rubber Plugs.
  - b. From behind bumper, push plugs into sensor mounting holes.**Models with bumper mounted sensors:**
  - a. Remove the small factory sealing washer from the sensor. Attach the provided larger (1) Foam Washer onto the front of the sensor.
  - b. Push the sensor in from the back of the Bumper until it is flush with the sensor sleeve. **NOTE:** Sensor tabs may need to be trimmed to fit sensor inside the sensor sleeve. Attach the adhesive side of (1) Foam Spacer to (1) Retaining Ring. Push the Retaining Ring into the sensor sleeve until it locks into the mounting holes, **(Figure 6)**.
  - c. Repeat the previous steps to install each sensor to the back of the Bumper.
6. **LED light installation at ends of bumper** as supplied with bumper or sold separately.
  - a. Insert light into opening and up to mounting slots. Check for clearance between front and back of light. If necessary, remove the plate from the back of the opening for additional clearance or access to light, **(Figure 7)**.
  - b. Follow the light manufacturer's instructions to attach (1) light to the center slot or (2) lights to the inner and outer slots in the top of the light opening.
  - c. Repeat the above steps for passenger side light installation.
  - d. Follow light manufacturer's instructions to properly wire the light.
7. With assistance, position the Bumper Assembly up to the mounting flanges on the end of the frame. Temporarily support the weight of the Bumper. **WARNING:** To avoid possible injury or damage to the vehicle, do not proceed until the bumper is fully and safely supported.
8. Attach the Bumper Brackets to the ends of the frame with the included (6) 12mm x 50mm Hex Bolts, (12) 12mm Flat Washers and (6) 12mm Nylon Lock Nuts, **(Figures 8A & 8B)**. Do not tighten hardware.
9. Level and adjust the bumper and fully tighten all hardware including the Mounting Bracket to Bumper hardware.
10. Reinstall the license plate lights and trailer plug, **(Figure 9)**. **NOTE:** Use a flat blade screwdriver to carefully pry the metal clip on the plug out to grab the edge of the opening.
11. Use the included (2) push-in plugs to attach the license plate to the Bumper, **(Figure 10)**.
12. Attach the wiring harness to the lights and trailer plug.
13. Use the included Wire Ties to secure the wiring harness to the bumper and frame as necessary.
14. Do periodic inspections to the installation to make sure that all hardware is secure and tight.

### Passenger Side Installation Pictured

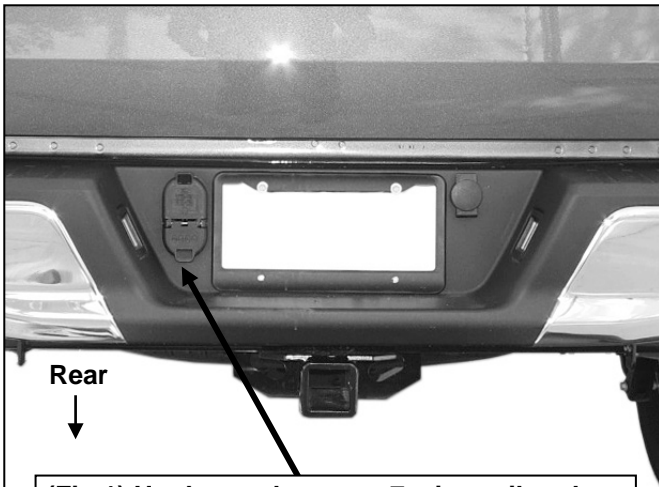

(Fig 1) Unplug and remove 7-wire trailer plug



(Fig 2) Unplug license plate lights

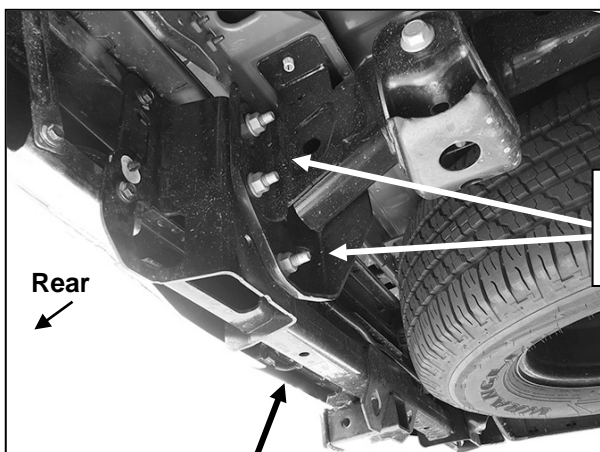

Remove the factory hex nuts attaching bumper assembly to frame

(Fig 3A) Note bumper with integrated receiver hitch



(Fig 3B) Remove the factory hex nuts attaching bumper assembly to frame. STD tow package model pictured (no receiver hitch)

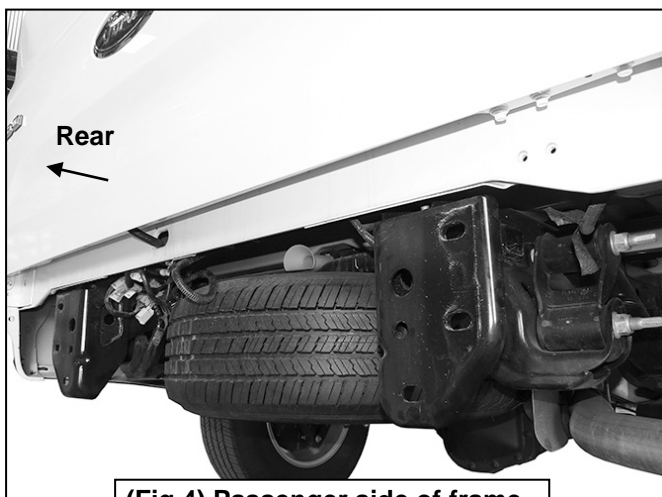

(Fig 4) Passenger side of frame

**WARNING!** Do not remove bumper bolts unless the bumper is properly supported on blocks or stands or the bumper may fall.

### Passenger Side Installation Pictured

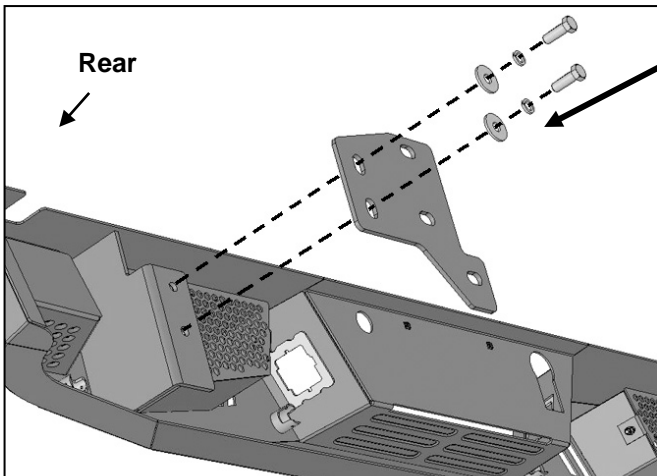

(Fig 5A) Attach Mounting Bracket to back of Bumper

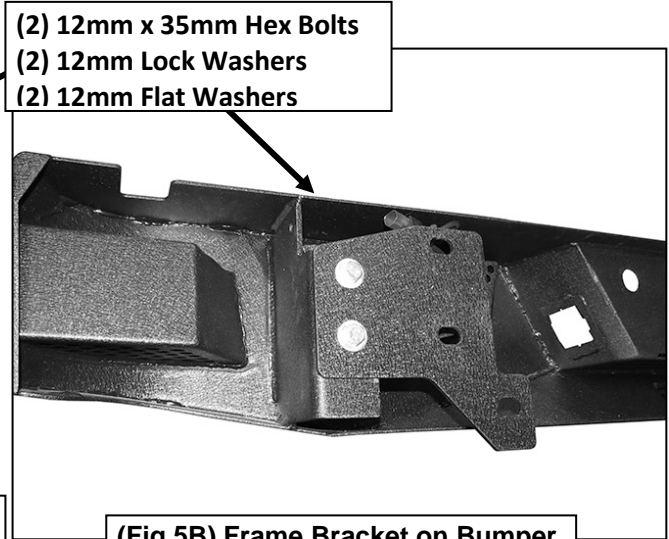

(Fig 5B) Frame Bracket on Bumper

**WARNING!** Do not crawl under bumper unless the bumper is properly supported on blocks or stands or the bumper may fall.

Remove plate if necessary for additional clearance around or access to lights

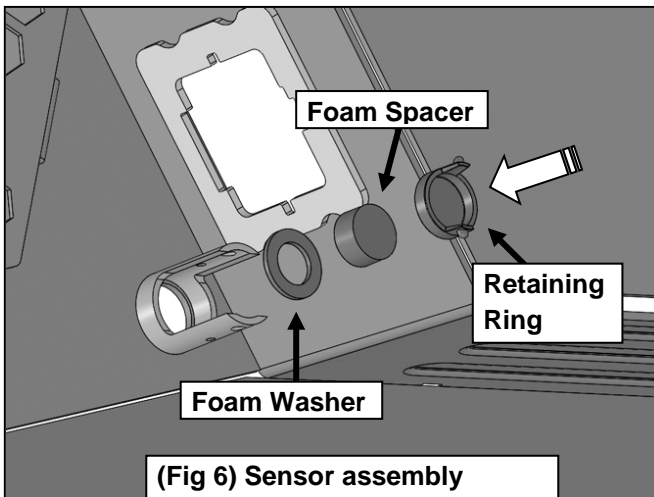

(Fig 6) Sensor assembly pictured from back of bumper

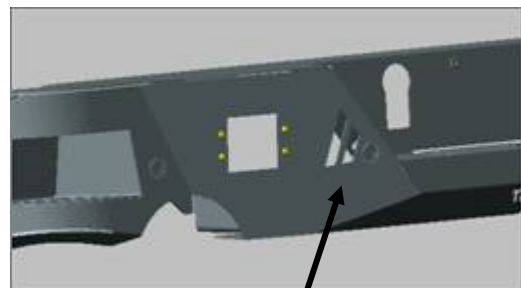

(Fig 9) Attach single light to center slot or use inner and outer slots for dual lights

### Passenger Side Installation Pictured

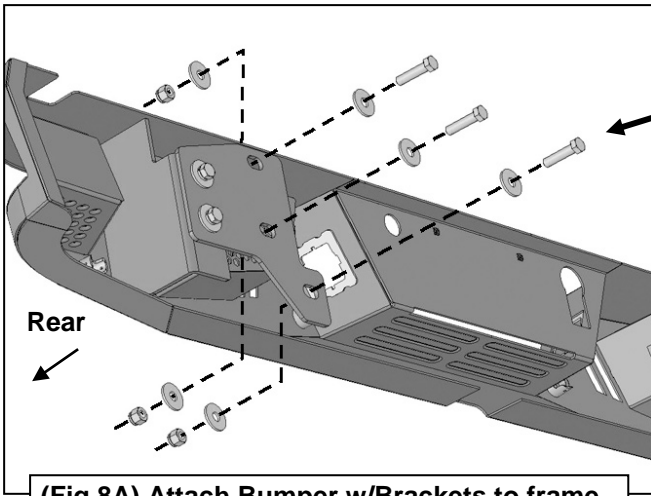

**(Fig 8A) Attach Bumper w/Brackets to frame**

- (3) 12mm x 50mm Hex Bolts
- (6) 12mm Flat Washers
- (3) 12mm Nylon Lock Nuts

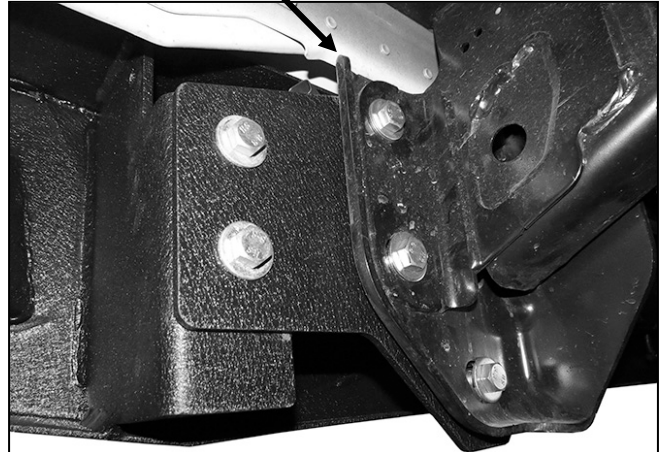

**(Fig 8B) Attach Bumper w/Brackets to frame**

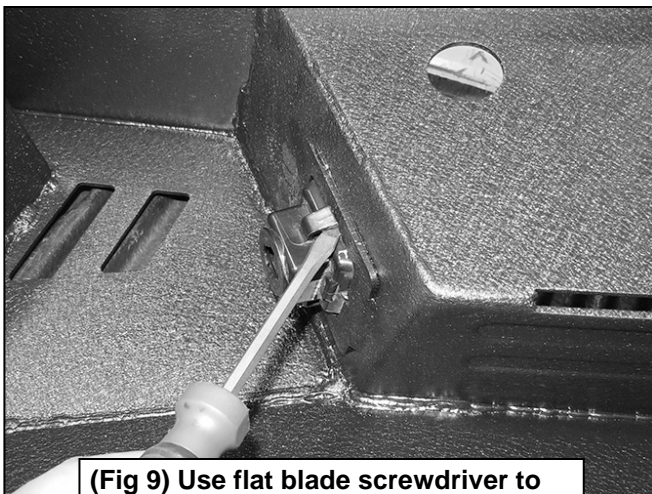

**(Fig 9) Use flat blade screwdriver to carefully pry tab to hold light in place**

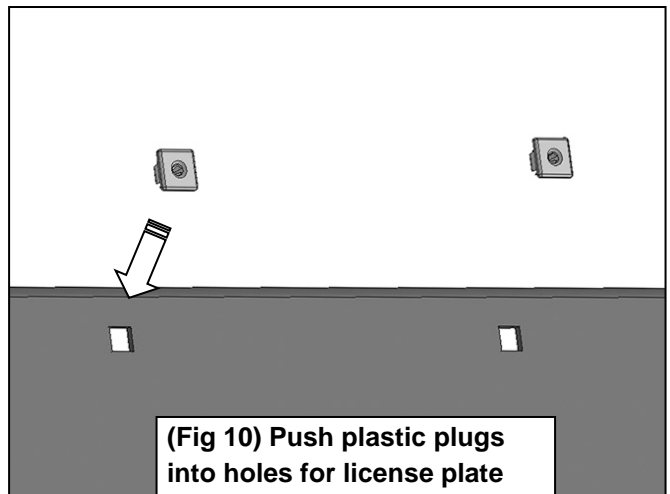

**(Fig 10) Push plastic plugs into holes for license plate**

**PRODUCT CARE**

- Periodically check the product to ensure all fasteners are tight and components are intact.
- Regular waxing is recommended to protect the finish of the product.
- **Use ONLY Non-Abrasive automotive wax.** Use of any soap, polish or wax that contains an abrasive is detrimental and can scratch the finish leading to corrosion.
- Aluminum polish may be used to polish small scratches and scuffs for **Stainless Steel finish.**
- Mild soap may be used to clean the product for both **Stainless Steel and Black finish.**

**FAQ'S****1. Hardware's are not of correct size.**

*In GMC / Chevrolet truck model 2006 & up, customer needs to reuse the factory body bolts to install the bracket. If your vehicle is not GMC / Chevrolet 2006 & up, ensure that holes are not partially covered with any plastic grommet or rust? If it is, remove the plastic grommet & rust from the thread holes & re-try the installation.*

**2. Mounting Bracket are not getting Installed properly.**

*In some cases Illustration images shown in Installation manual may not be the exactly same as per actual vehicle images ,also if Driver / Passenger side mounting brackets are very identical in the design, suggest referring Parts Identification guide to avoid fitment issue.*

**3. Products are thumping / rattling after installation.**

*Ensure that all required mounting brackets / hardware's are installed & tighten correctly. Suggest using white lithium / regular grease between the metal to metal contact surfaces.*

**4. Side Bar is not aligning with vehicle / Step Pads are not aligning with vehicle doors.**

*Side bar may be interchanged or mounting brackets are not installed at the correct position in the vehicle. Refer Parts identification guide.*

**5. Missing / Excess Hardware.**

*Recheck hardware count as per the part list.*

**6. Product not installing properly.**

*Ensure make model year, cab length and bed size of your vehicle is listed in the application. All installation steps are followed correctly.*

**Check out these other TrailFX Products!!**

**www.TrailFX.com**



**SIDE BAR**

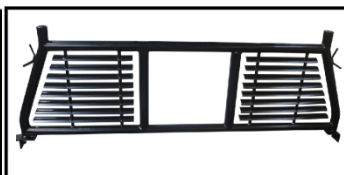

**HEADACHE RACKS**

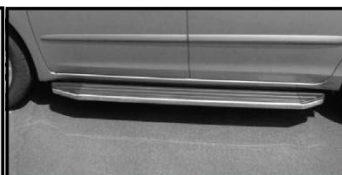

**RUNNING BOARDS**



**ROCKER GUARDS**

*Keystone Automotive Operations Inc. (KAO) warrants this product to be free of defects in material and workmanship at the time of purchase by the original retail consumer. KAO disclaims any other warranties, express or implied, including the warranty of fitness for a particular purpose or an intended use. If the product is found to be defective, KAO may replace or repair the product at our option, when the product is returned prepaid, with proof of purchase. Alteration to, improper installation, or misuse of this product voids the warranty. KAO's liability is limited to repair or replacement of products found to be defective, and specifically excludes liability for any incidental or consequential loss or damage.*