

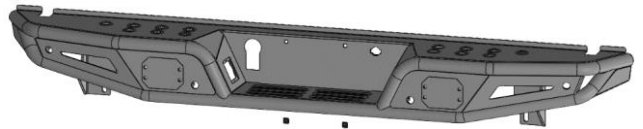

**NB3 REAR BUMPER**  
**Part No. RPRB004TI**



**Fits: 2015-2019 FORD F150**



Including Diesel models with DEF tanks



REMOVE CONTENTS FROM BOX. VERIFY ALL PARTS ARE PRESENT.



READ INSTRUCTIONS CAREFULLY BEFORE STARTING INSTALLATION.

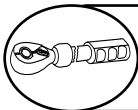

DO NOT OVER TORQUE. STANDARD OPERATING LOAD FOR TIGHTEN BODY MOUNT NUTS & BOLTS VARIES FROM 45 TO 65 FOOT POUND.



60-180 min

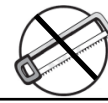

Cutting is not Required



Drilling is not Required



support@trailfx.com



1 866 638 4870



POLISHED STAINLESS STEEL - LIMITED LIFETIME  
 POWDER COATED BLACK - 3 YEARS

**PARTS LIST:**

Qty	Part Description	Qty	Part Description
1	NB3 Rear Bumper	1	Sensor Cover Kit
1	Driver/Left Mounting Bracket	2	10mm Double Bolt Plates
1	Passenger/Right Mounting Bracket	4	10mm Plastic Retainers
2	License Plate Plugs	4	10mm x 30mm x 2.5mm Flat Washers
4	Sensor Hole Plugs	4	10mm Nylon Lock Nuts
4	20mm x 10mm Foam Spacer Washers	8	4mm x 10mm Button Head Bolts
4	25mm x 15.5mm x 2mm Foam Washers	10	Wire Ties
4	Sensor Retaining Clips	1	2.5mm Hex Wrench

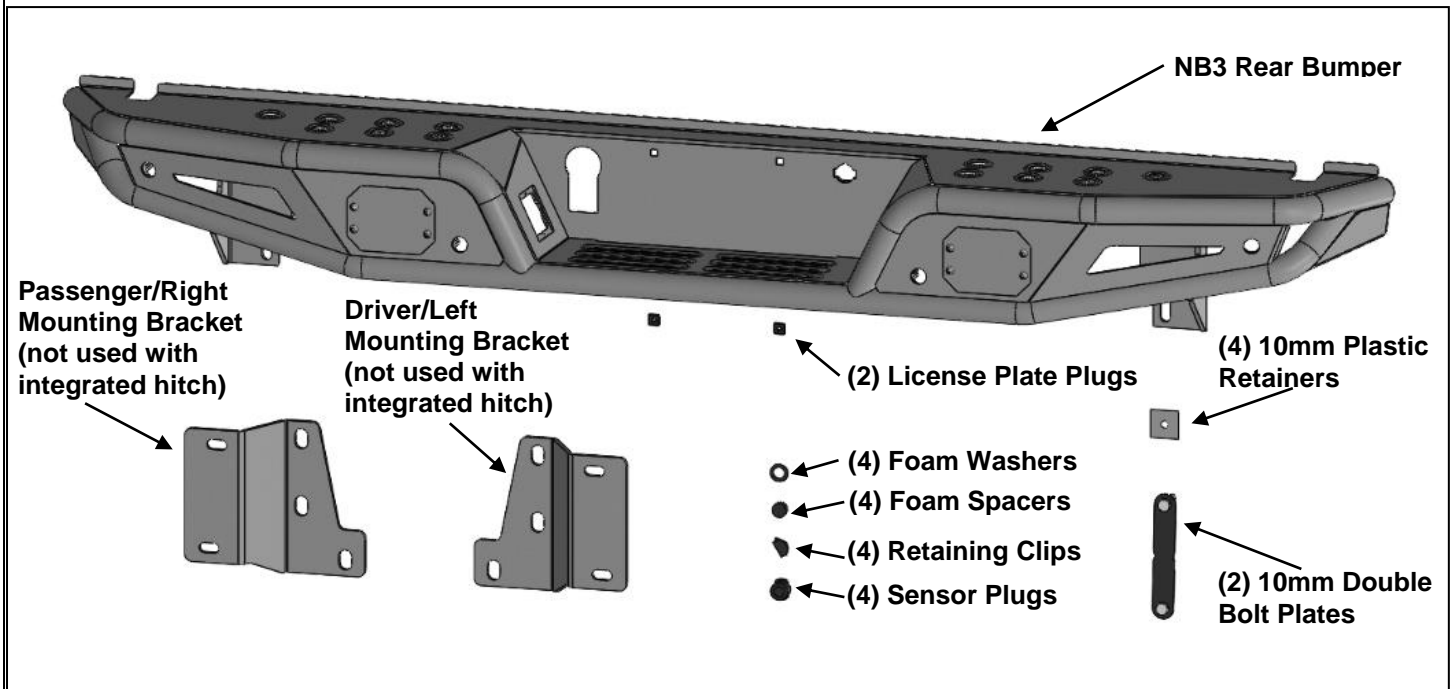

**PROCEDURE:**

REMOVE CONTENTS FROM BOX. VERIFY ALL PARTS ARE PRESENT. READ INSTRUCTIONS CAREFULLY BEFORE STARTING INSTALLATION. BUMPER IS HEAVY, ASSISTANCE IS RECOMMENDED TO AVOID POSSIBLE INJURY OR DAMAGE TO THE VEHICLE. IMPORTANT: OEM BUMPER REINFORCEMENT USED WITH "STANDARD" TOW PACKAGE WITHOUT RECEIVER HITCH CANNOT BE REINSTALLED. OE INTEGRATED "HD" HITCH, "MAX DUTY" HITCH AND MOST AFTERMARKET RECEIVER HITCHES REQUIRED FOR TOWING.

1. Remove the license plate from the bumper, **(Figure 1)**. Next, unplug the license plate lights, trailer plug and sensors, if equipped, **(Figure 2)**. Unplug the wiring harness leading to the bumper. Move wiring harness away from bumper. **NOTE:** Bumper is designed to be compatible with larger 7-wire universal trailer harness plug only.
2. Place blocks or jack stands under the bumper to support it during mounting bolt removal. Once the bumper has been safely supported, remove the factory hardware attaching the bumper to the end of the frame and remove the bumper, **(Figures 3A, 3B & 4)**. **WARNING!** Assistance is required to hold the bumper in place during hardware removal to prevent bumper from falling.
3. Remove the wiring harness, license plate lights, trailer plug and spare access lock from the factory bumper. Remove sensors, (if equipped), from bumper.
4. Determine if the vehicle is equipped with sensors

**Models without bumper sensors:**

- a. Select (1) Sensor Plug.
- b. Insert plug into sensor sleeve on the back of the NB3 Bumper, **(Figure 5)**. **Optional:** Use (2) 4mm Button Head Bolts to secure the plug.
- c. Repeat previous **Steps** to insert the remaining (3) sensor plugs.

**Models with bumper mounted sensors:**

- a. Select (1) sensor. Remove the silicone seal from the end of the sensor, **(Figure 6)**.
- b. Slide (1) 25mm x 15.5mm Foam Washer over front of sensor, **(Figure 6)**.
- c. Insert sensor with Foam Washer into sensor sleeve in the back of the NB3 Bumper.
- d. Place 20mm x 10mm Foam Spacer over end of sensor. Push Sensor Retaining Clip into sensor sleeve, **(Figure 7)**.
- e. Repeat previous **Steps** to install remaining (3) sensors.
- f. Install wiring harness from factory bumper.
- g. **Optional:** Secure each sensor to the socket with (2) 4mm x 10mm Button Head Bolts, **(Figure 5)**. **IMPORTANT:** Sensors fit snug in sockets. The 4mm Bolts are used to apply slight pressure to lock the sensors in place. Tighten both screws evenly until they touch the sensor body only. Do not overtighten bolts or damage to sensors will result.

**5. Optional Light installation (Light not included).**

- a. Remove the fill panels located on the NB3 Bumper, **(Figure 8)**.
- b. Follow instructions included with lights to attach to Bumper, (lights not included).

**6. Select (1) 10mm Double Bolt Plate and (2) 10mm Plastic Retainers. Insert the Double Bolt Plate into the Driver/Left mounting plate on the Bumper. Thread the Retainers down onto the threads of the Bolt Plate to help hold it in position, (Figure 9). Repeat this Step to attach the remaining 10mm Double Bolt Plate on the Passenger/Right side of the Bumper.**

**7. Use a small flat blade screwdriver to pry the star washers off the factory bolt plates used to attach the factory bumper to the frame, (Figure 10). NOTE: "HD" tow package models use a triple bolt plate, "Standard" and "Max Duty" equipped models use a double bolt plate.**

**8. Determine tow package on model**

**Models with "standard tow package" without HD receiver below bumper and models with "Max Duty" frame mounted receiver hitch below bumper.**

- a. Attach the Driver/Left Mounting Bracket to the frame with (1) factory bolt plate (2 or 3-bolt) and (2 or 3) factory hex nuts, **(Figures 11 & 12)**. Do not tighten hardware.
- b. Repeat the previous **Step** to attach the Passenger/Right Mounting Bracket.
- c. With assistance, hold the NB3 Bumper up to the Mounting Brackets. Temporarily support the weight of the Bumper. **WARNING:** To avoid possible injury or damage to the vehicle, do not proceed until the bumper is fully and safely supported.
- d. Attach the Bumper to the Mounting Brackets with (4) 10mm Flat Washers and (4) 10mm Nylon Lock Nuts, **(Figure 13)**. Do not tighten hardware.

**Models with "HD" tow package with receiver hitch.**

- a. Remove the integrated receiver hitch and bracket assembly from back of bumper.
- b. Use factory hardware to reinstall receiver/bumper bracket assembly to mounts on end of frame, **(Figure 14)**. Do not fully tighten hardware.
- c. With assistance, temporarily support the weight of the NB3 Bumper. **WARNING:** To avoid possible injury or damage to the vehicle, do not proceed until the bumper is fully and safely supported.
- d. Attach the Bumper to the integrated receiver/bumper bracket with (4) 10mm Flat Washers and (4) 10mm Nylon Lock Nuts, **(Figure 15)**. Do not tighten hardware.

**9. Level and adjust the Bumper and fully tighten all hardware.**

10. Insert the license plate lights, spare access lock and trailer plug into the NB3 Bumper. **NOTE:** Use a flat blade screwdriver to carefully pry the metal clips on the plug out to grab the edge of the opening. Plug the bumper harness into the lights, trailer plug and sensors (if equipped).
11. Plug the Bumper wiring harness into the main harness. Use the included Wire Ties to secure the wiring harness to the bumper and frame as necessary.
12. Use the included (2) push-in plugs to attach the license plate to the Bumper, **(Figure 16)**.
13. Do periodic inspections to the installation to make sure that all hardware is secure and tight.

**To protect your investment,** Do not use any type of polish or wax that may contain abrasives that could damage the finish. Mild soap may be used to clean the Bumper assembly.



**(Fig 1) Unplug and remove 7-wire trailer plug**

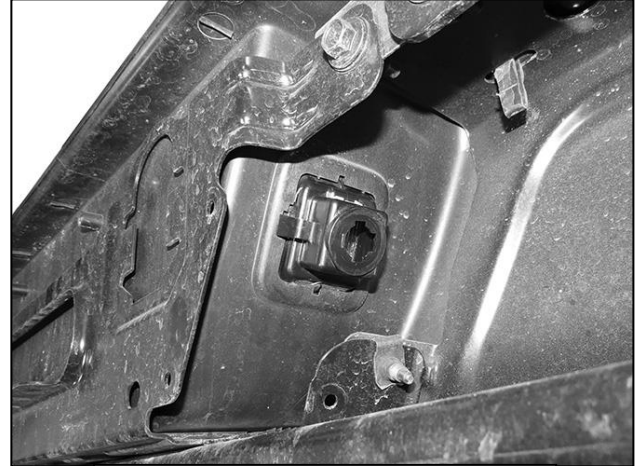

**(Fig 2) Unplug license plate lights**

**WARNING!** Do not crawl under bumper unless the bumper is properly supported on blocks or stands or the bumper may fall.

Remove the factory hex nuts attaching bumper assembly to frame

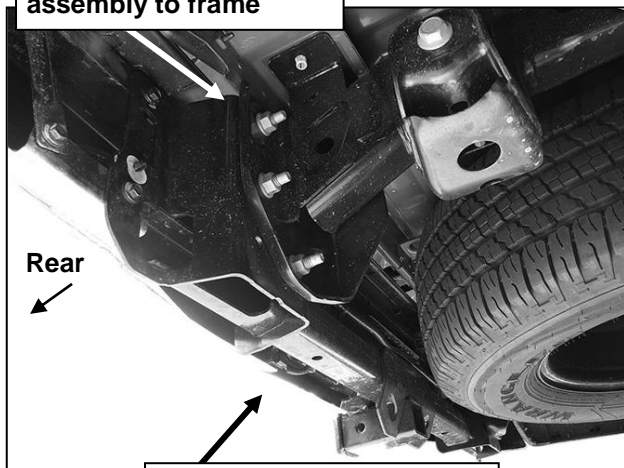

**(Fig 3A) Note bumper with integrated receiver hitch**

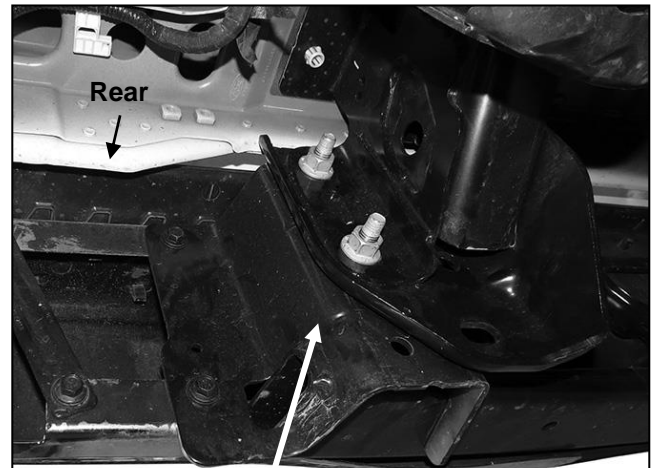

**(Fig 3B) Remove the factory hex nuts attaching bumper assembly to frame. STD tow package model pictured (no receiver hitch)**



(Fig 4) Bumper removed, passenger side pictured without receiver hitch

**WARNING!** Do not remove bumper bolts unless the bumper is properly supported on blocks or stands or the bumper may fall.

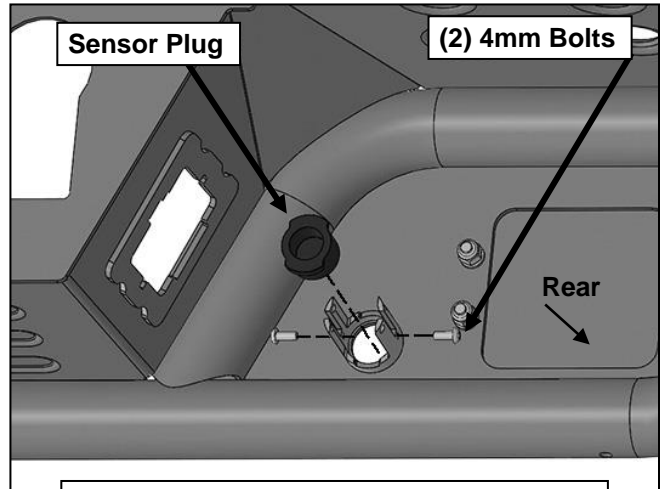

(Fig 5) Push sensor plug into mounting sleeve. Use of 4mm Bolts is optional

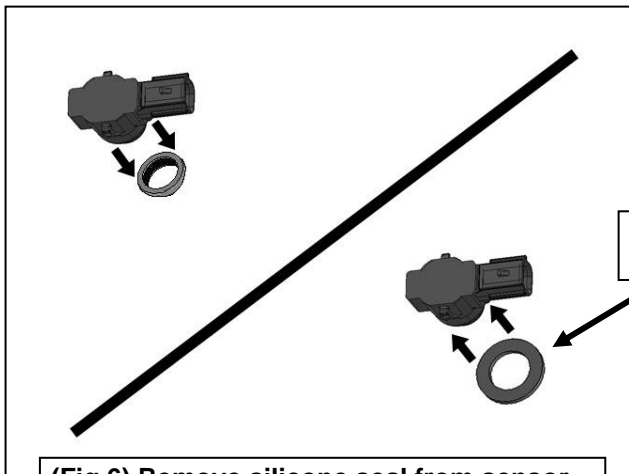

25mm x 15.5mm  
Foam Washer

(Fig 6) Remove silicone seal from sensor. Slide Foam Washer over end of sensor

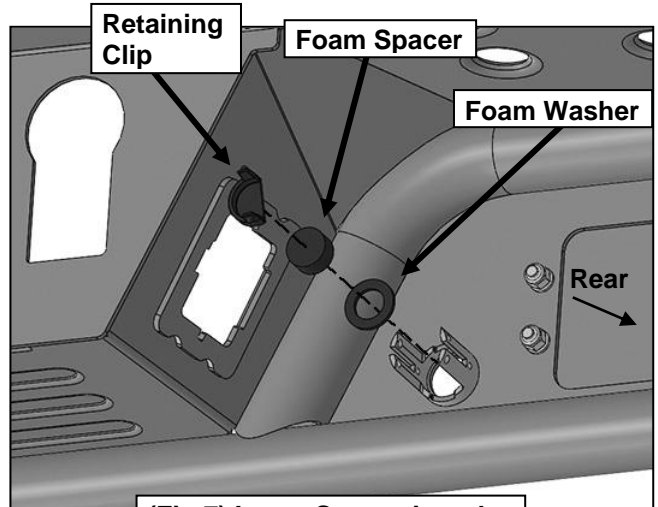

(Fig 7) Insert Sensor into the backside of the Bumper

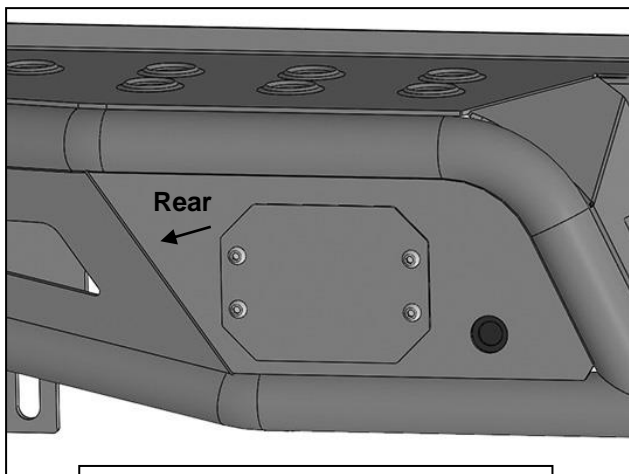

(Fig 8) Remove panel to attach light to the Bumper (light not included)

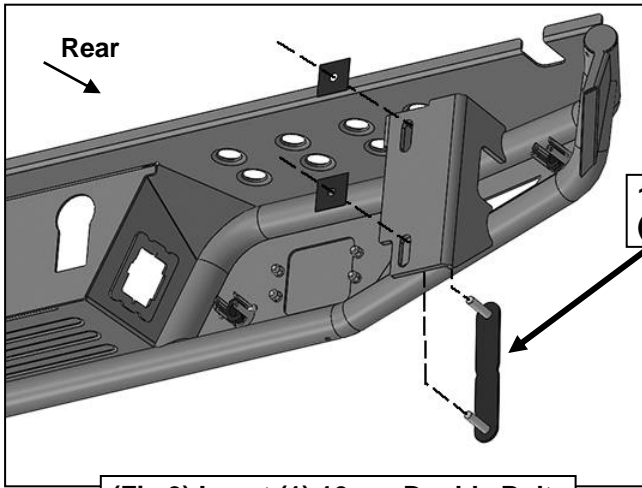

**WARNING!** Do not crawl under bumper unless the bumper is properly supported on blocks or stands or the bumper may fall.

**10mm Double Bolt Plate  
(2) 10mm Plastic Retainer**

**(Fig 9) Insert (1) 10mm Double Bolt Plate into the Driver/Left mounting plate on the back of Bumper**

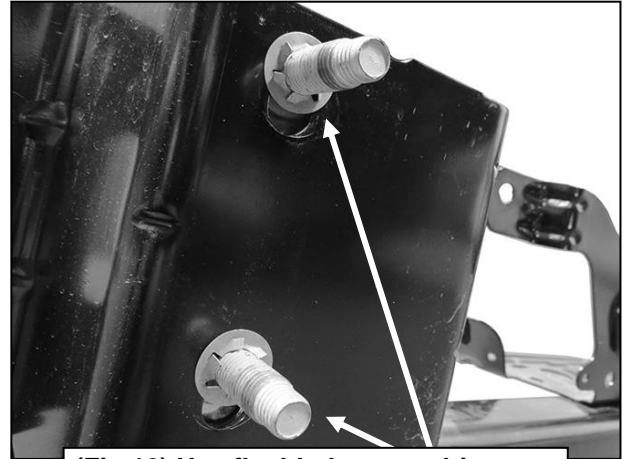

**(Fig 10) Use flat blade screwdriver to pry off lock washers from bolt plates**

**Factory triple bolt plate used with "HD tow" package with integrated receiver hitch**

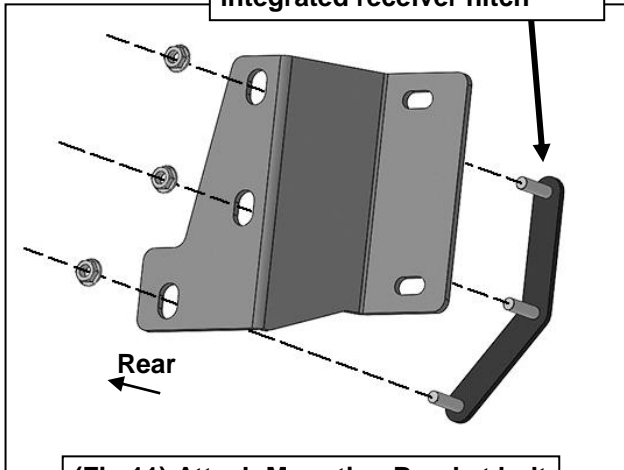

**(Fig 11) Attach Mounting Bracket bolt plate to Driver/Left frame (Models with factory triple bolt plate shown)**

**Factory double bolt plate used on model's w/o receiver hitch and "max tow" frame mounted receiver hitch**

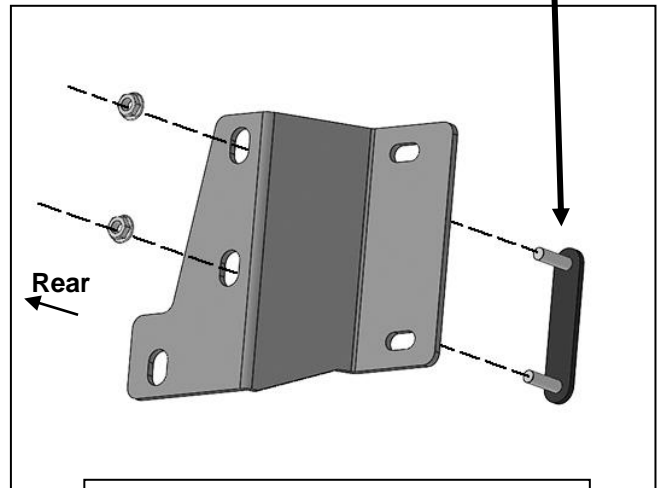

**(Fig 12) Attach Mounting Bracket bolt plate to Driver/Left frame (Models with factory double bolt plate shown)**

(2) 10mm Flat Washers  
(2) 10mm Nylon Lock Nuts

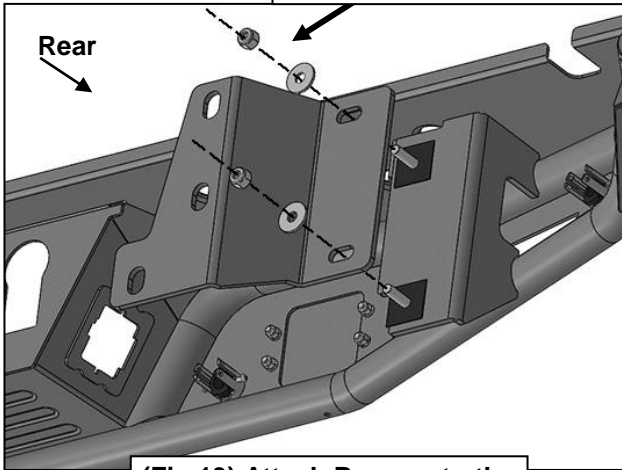

(Fig 13) Attach Bumper to the Driver/Left Mounting Bracket

**WARNING!** Do not crawl under bumper unless the bumper is properly supported on blocks or stands or the bumper may fall.

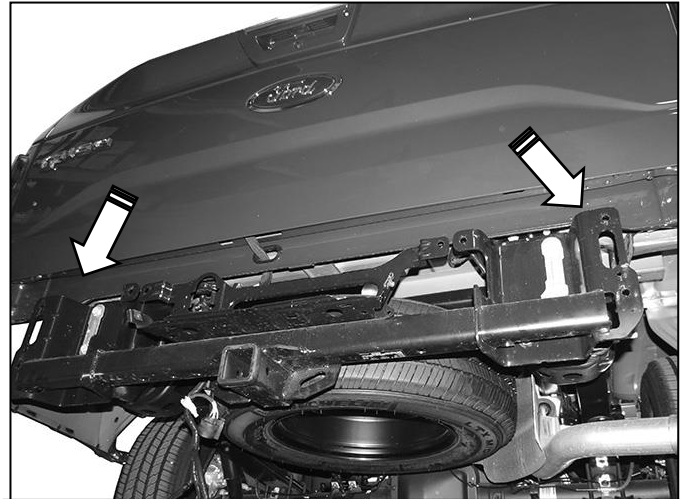

(Fig 14) Reinstall integrated receiver hitch/bracket assembly on models with "HD Towing" package

(2) 10mm Flat Washers  
(2) 10mm Nylon Lock Nuts

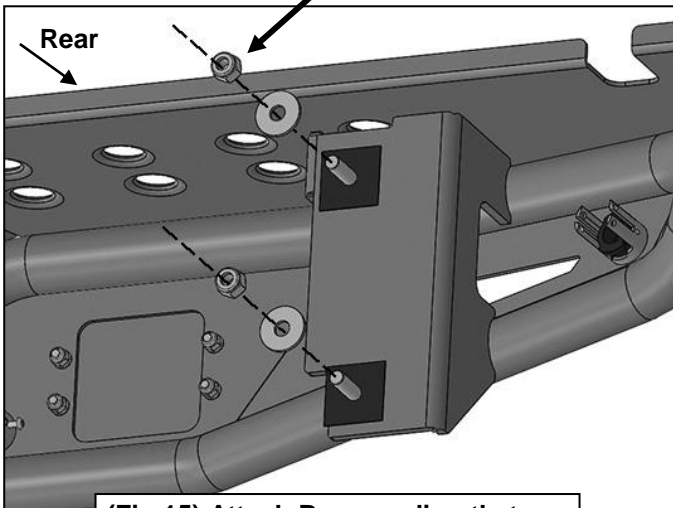

(Fig 15) Attach Bumper directly to integrated hitch bracket (see Fig 14)

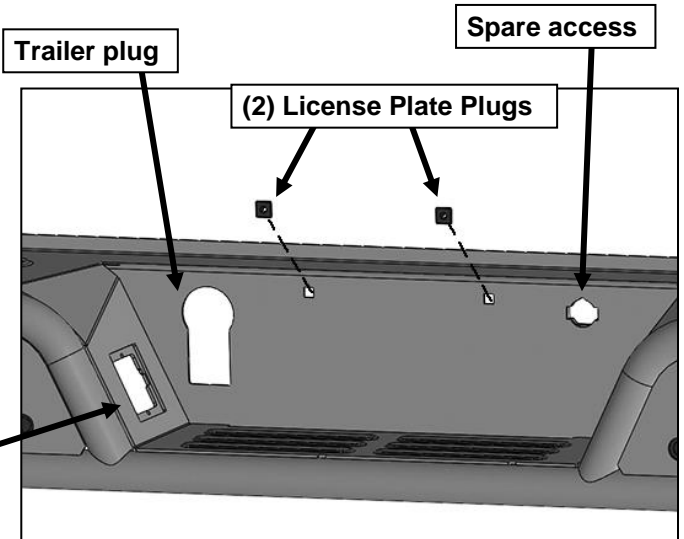

(Fig 16) Push plastic plugs into holes for license plate



**PARTS IDENTIFICATION GUIDE**

*Driver Side tube packed using "Green" color foam sheet. Passenger Side tube packed using "White" color foam sheet*

No.	Parts Identification
1	Passenger / Right 'Rear' Bracket marked "PR"
2	Driver / Left 'Rear' Bracket marked "DR"
3	Passenger / Right 'Center' Bracket marked "PC"
4	Driver / Left 'Center' Bracket marked "DC"
5	Passenger / Right 'Front' Bracket marked "PF"
6	Driver / Left 'Front' Bracket marked "DF"

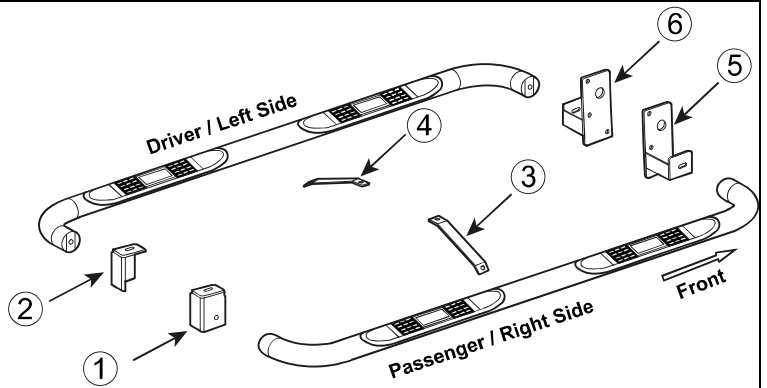

**Note:**  
 > This guide is to identify the parts and not a reference for part count.  
 > For part count, refer Parts List.  
 > Product / Bracket image is representative and actual design may vary.

**PRODUCT CARE**

- Periodically check the product to ensure all fasteners are tight and components are intact.
- Regular waxing is recommended to protect the finish of the product.
- **Use ONLY Non-Abrasive automotive wax.** Use of any soap, polish or wax that contains an abrasive is detrimental and can scratch the finish leading to corrosion.
- Aluminum polish may be used to polish small scratches and scuffs for **Stainless Steel finish.**
- Mild soap may be used to clean the product for both **Stainless Steel and Black finish.**

**FAQ's**

**1. Hardware's are not of correct size.**

*In GMC / Chevrolet truck model 2006 & up, customer needs to reuse the factory body bolts to install the bracket. If your vehicle is not GMC / Chevrolet 2006 & up, ensure that holes are not partially covered with any plastic grommet or rust? If it is, remove the plastic grommet & rust from the thread holes & re-try the installation.*

**2. Mounting Bracket are not getting Installed properly.**

*In some cases Illustration images shown in Installation manual may not be the exactly same as per actual vehicle images ,also if Driver / Passenger side mounting brackets are very identical in the design, suggest referring Parts Identification guide to avoid fitment issue.*

**3. Products are thumping / rattling after installation.**

*Ensure that all required mounting brackets / hardware's are installed & tighten correctly. Suggest using white lithium / regular grease between the metal to metal contact surfaces.*

**4. Side Bar is not aligning with vehicle / Step Pads are not aligning with vehicle doors.**

*Side bar may be interchanged or mounting brackets are not installed at the correct position in the vehicle. Refer Parts identification guide.*

**5. Missing / Excess Hardware.**

*Recheck hardware count as per the part list.*

**6. Product not installing properly.**

*Ensure make model year, cab length and bed size of your vehicle is listed in the application. All installation steps are followed correctly.*

**Check out these other TrailFX Products!!**

[www.TrailFX.com](http://www.TrailFX.com)



*Keystone Automotive Operations Inc. (KAO) warrants this product to be free of defects in material and workmanship at the time of purchase by the original retail consumer. KAO disclaims any other warranties, express or implied, including the warranty of fitness for a particular purpose or an intended use. If the product is found to be defective, KAO may replace or repair the product at our option, when the product is returned prepaid, with proof of purchase. Alteration to, improper installation, or misuse of this product voids the warranty. KAO's liability is limited to repair or replacement of products found to be defective, and specifically excludes liability for any incidental or consequential loss or damage.*